

**NOTES**

1. RUNG SPACING TO BE BETWEEN 250 AND 300 ENSURING A CONSISTENT SPACING WHEN STEPPING ON AND OFF THE LADDER. RUNG SPACING TOLERANCE TO BE  $\pm 5$ .
2. LADDER HEIGHTS ABOVE THE FLOOR OF THE STRUCTURE SHALL NOT EXCEED 6 m UNLESS FITTED WITH A LADDER CAGE.
3. INDIVIDUAL LADDER LENGTHS SHALL NOT EXCEED 6 m.
4. DESIGNER TO SPECIFY OVERALL LADDER LENGTH ON PROJECT DRAWING(S).
5. THIS LADDER IS COMPATIBLE WITH THE ACCESS HATCH SHOWN ON DRAWING SD-8231.
6. QUANTITY AND MASS BASED ON A LADDER APPROX. 2500 IN LENGTH.
7. REFER TO DRAWING SD-9100 FOR STEELWORK NOTES.
8. ALL WORKS SHALL COMPLY WITH AS 1657 AND ICON WATER SUPPLEMENT DOCUMENTS STD-SPE-G-008 AND 009.

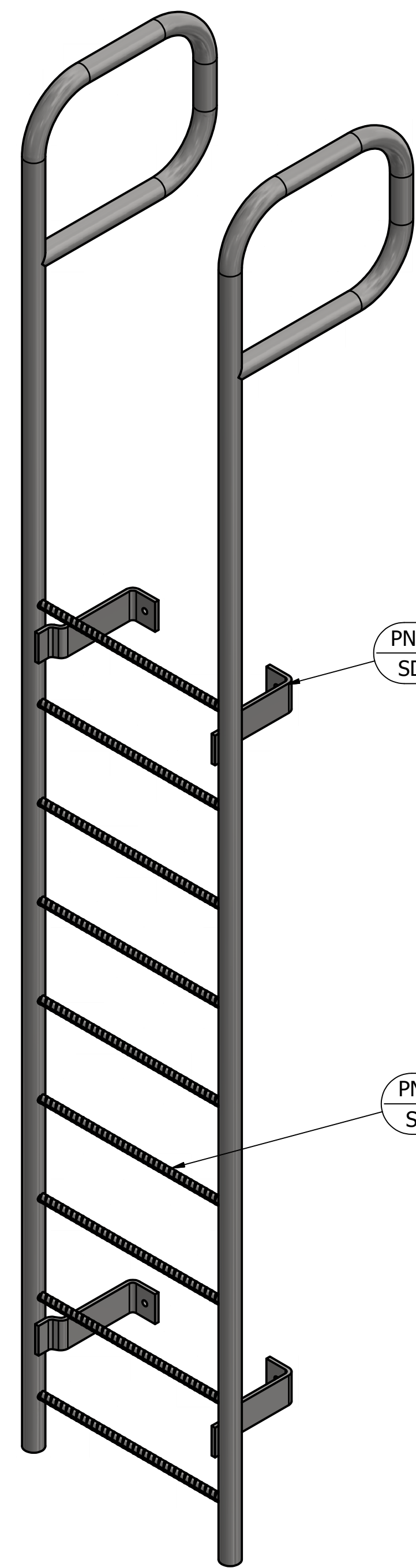

ISOMETRIC VIEW

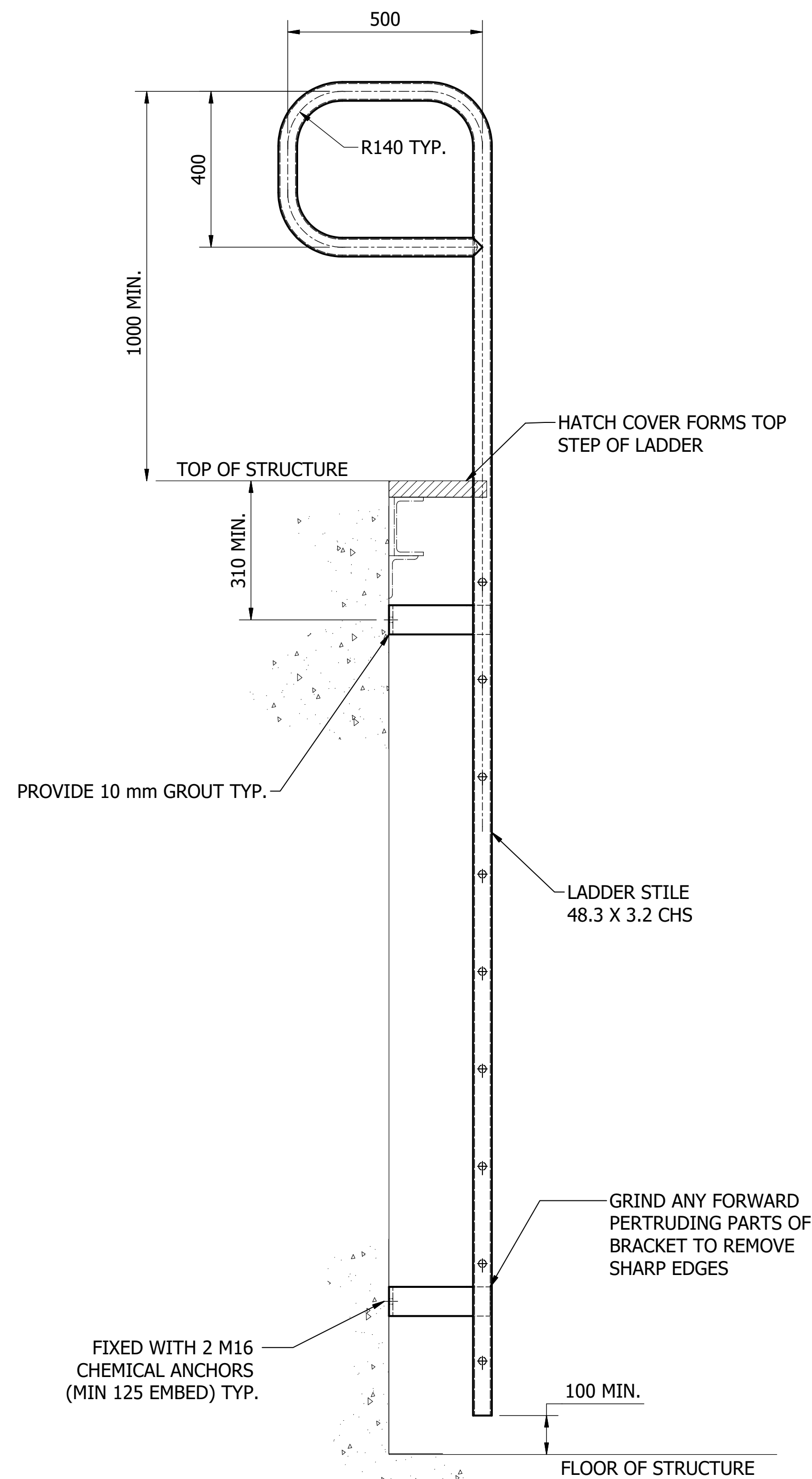

SIDE VIEW

LADDER STILE CHS  
OD 48.3 mm  
WT 4.0 mm

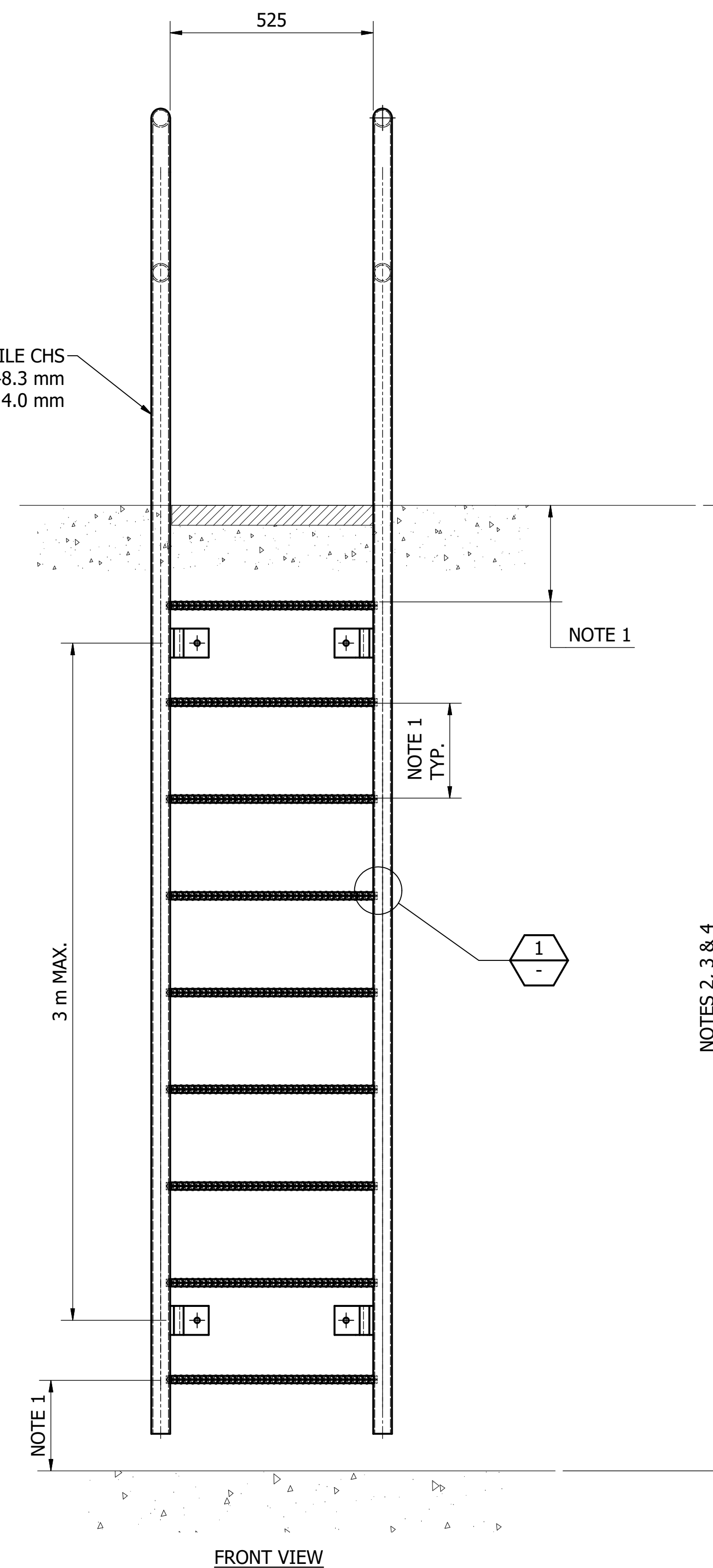

FRONT VIEW

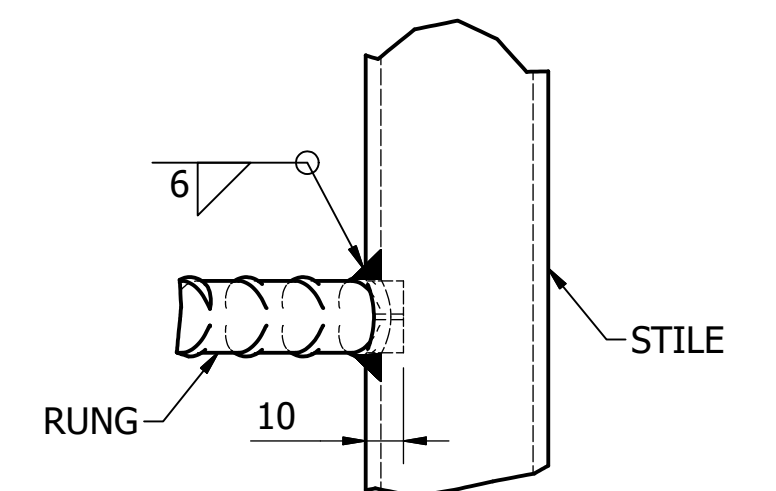

DETAIL 1

RUNG WELD DETAIL TYP.  
SCALE: 1 : 2

**VERTICAL RUNG LADDER  
WITH FIXED STANCHIONS - TYPICAL ASSEMBLY**  
SCALE: 1 : 10

MATERIAL: CARBON STEEL  
COATING: HOT DIP GALVANISED  
FINISH COLOUR: N/A  
MASS: DESIGNER TO PROVIDE PROJECT SPECIFIC DETAILS

PARTS LIST				
PART NUM	DESCRIPTION	QTY	MASS	REFERENCE
N/A	LADDER STILES	2	20.3 kg	SD-8101
PN815304	LADDER RUNG	VARIES	1.2 kg	SD-8153
PN815301	WALL BRACKET	4	1.9 kg	SD-8153

ITEM	AMDT.
PN810101	

No.	ISSUE	DATE	DRAWN	CHECKED	AUTHORISED
A	INITIAL ISSUE	15/06/2018	S. Essery	K. Danenbergsons	D. Eager

DAM	<input checked="" type="checkbox"/>	RES	<input checked="" type="checkbox"/>	SPS	<input checked="" type="checkbox"/>
BWS	<input checked="" type="checkbox"/>	WAT	<input checked="" type="checkbox"/>	STP	<input checked="" type="checkbox"/>
WTP	<input checked="" type="checkbox"/>	SEW	<input checked="" type="checkbox"/>		
WPS	<input checked="" type="checkbox"/>	REC	<input checked="" type="checkbox"/>		
ASSET AREA APPLICABILITY					



STANDARD DRAWING  
HOT DIP GALVANISED STEEL LADDERS  
FIXED VERTICAL RUNG LADDER WITH FIXED STANCHIONS  
ASSEMBLY AND DETAILS

DRAWING STATUS	
Current	
SD-8101-D	
A1	ISSUE A
© Icon Water 2017	

**NOTES:**

1. THE DESIGNER SHALL NOMINATE AN EVEN RUNG PITCH BETWEEN 250 AND 300 ENSURING A CONSISTENT PITCH WHEN STEPPING ON & OFF THE LADDER. RUNG PITCH TOLERANCE SHALL BE ± 5.
2. LADDER HEIGHTS ABOVE THE FLOOR OF THE STRUCTURE SHALL NOT EXCEED 6 m UNLESS FITTED WITH A LADDER CAGE.
3. INDIVIDUAL LADDER LENGTHS SHALL NOT EXCEED 6 m.
4. DESIGNER TO SPECIFY OVERALL LADDER LENGTH ON PROJECT DRAWING(S).
5. THIS LADDER IS COMPATIBLE WITH THE ACCESS HATCHES SHOWN ON SD-8201, 8211 AND 8231.
6. QUANTITY AND MASS BASED ON A LADDER APPROX 3000 IN LENGTH.
7. REFER TO DRAWING SD-9100 FOR STEELWORK NOTES.
8. ALL WORKS SHALL COMPLY WITH AS 1657 AND ICON WATER SUPPLEMENT DOCUMENTS STD-SPE-G-008 AND 009.

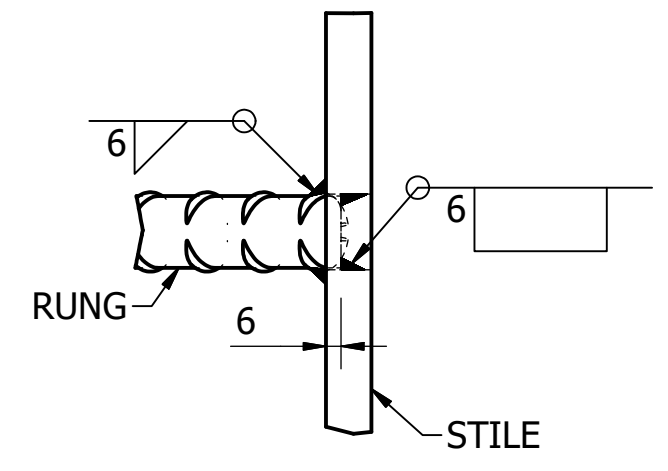
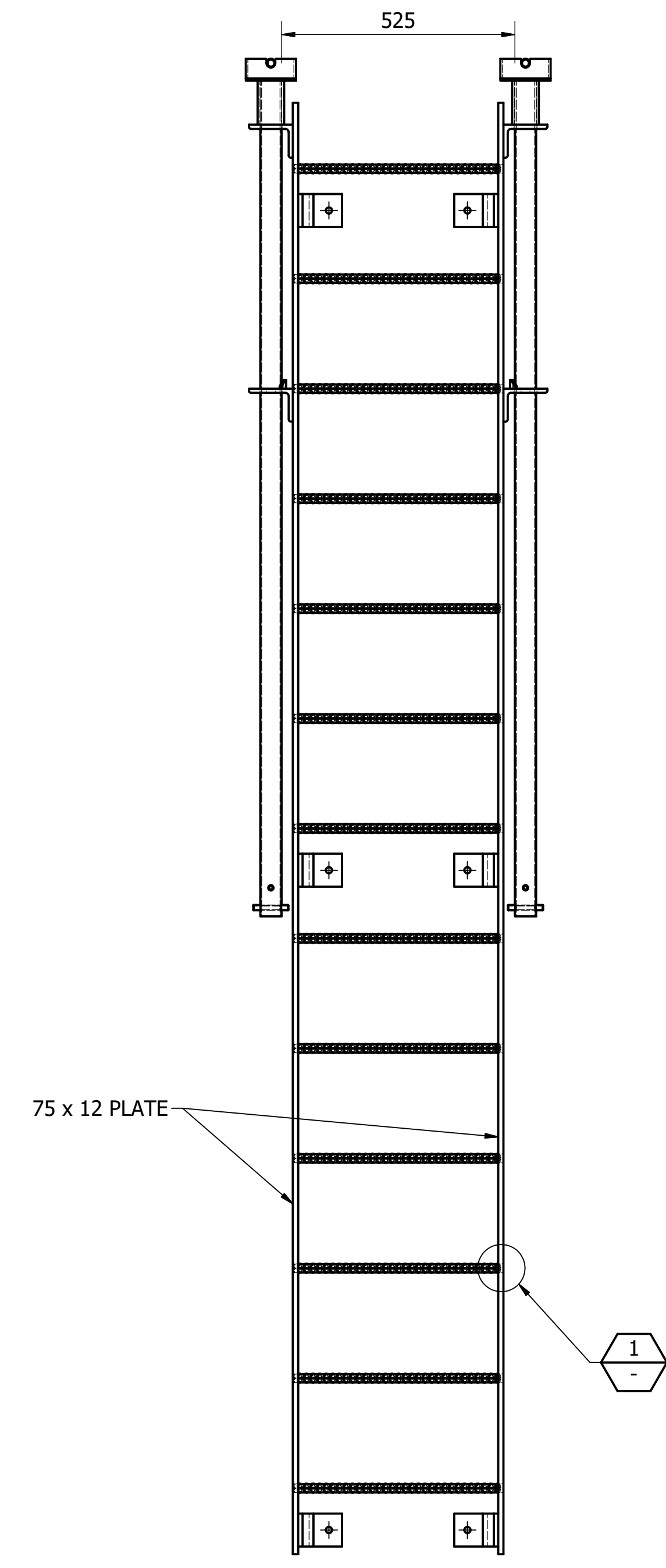
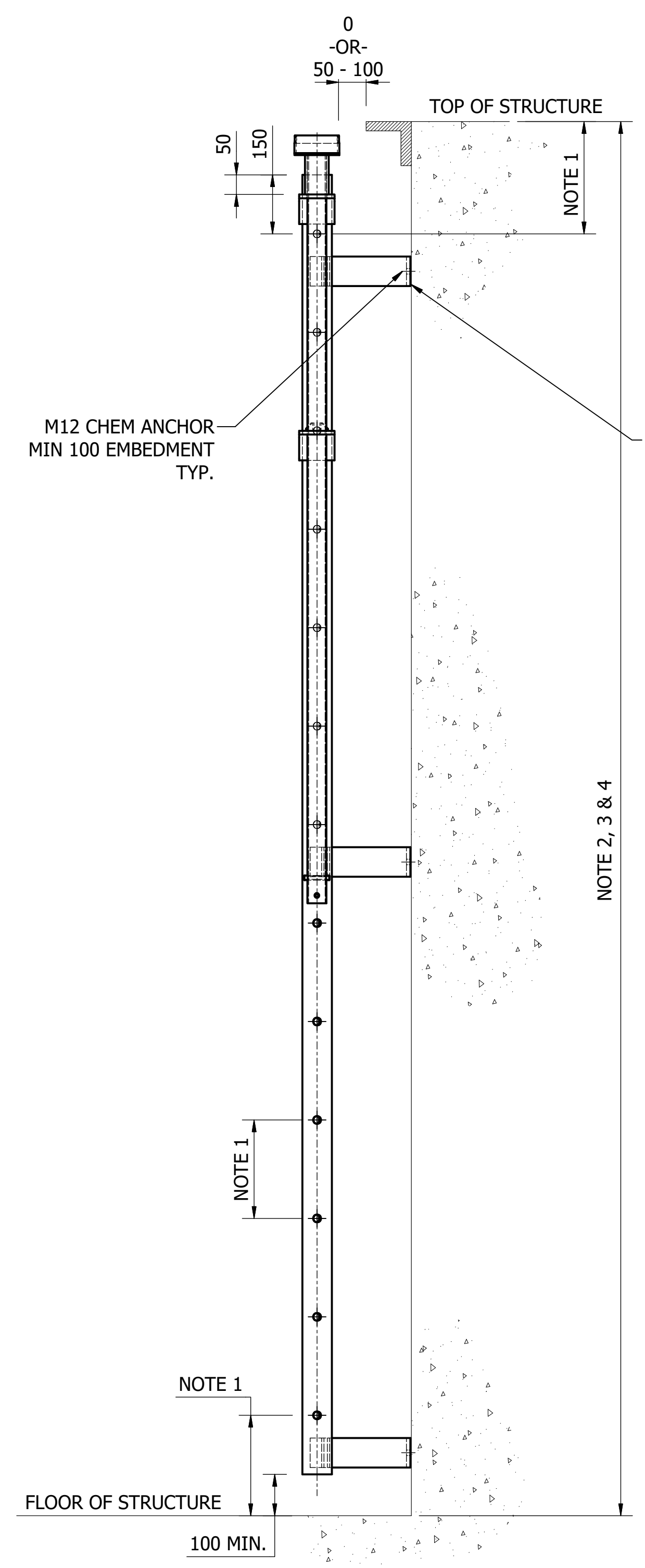
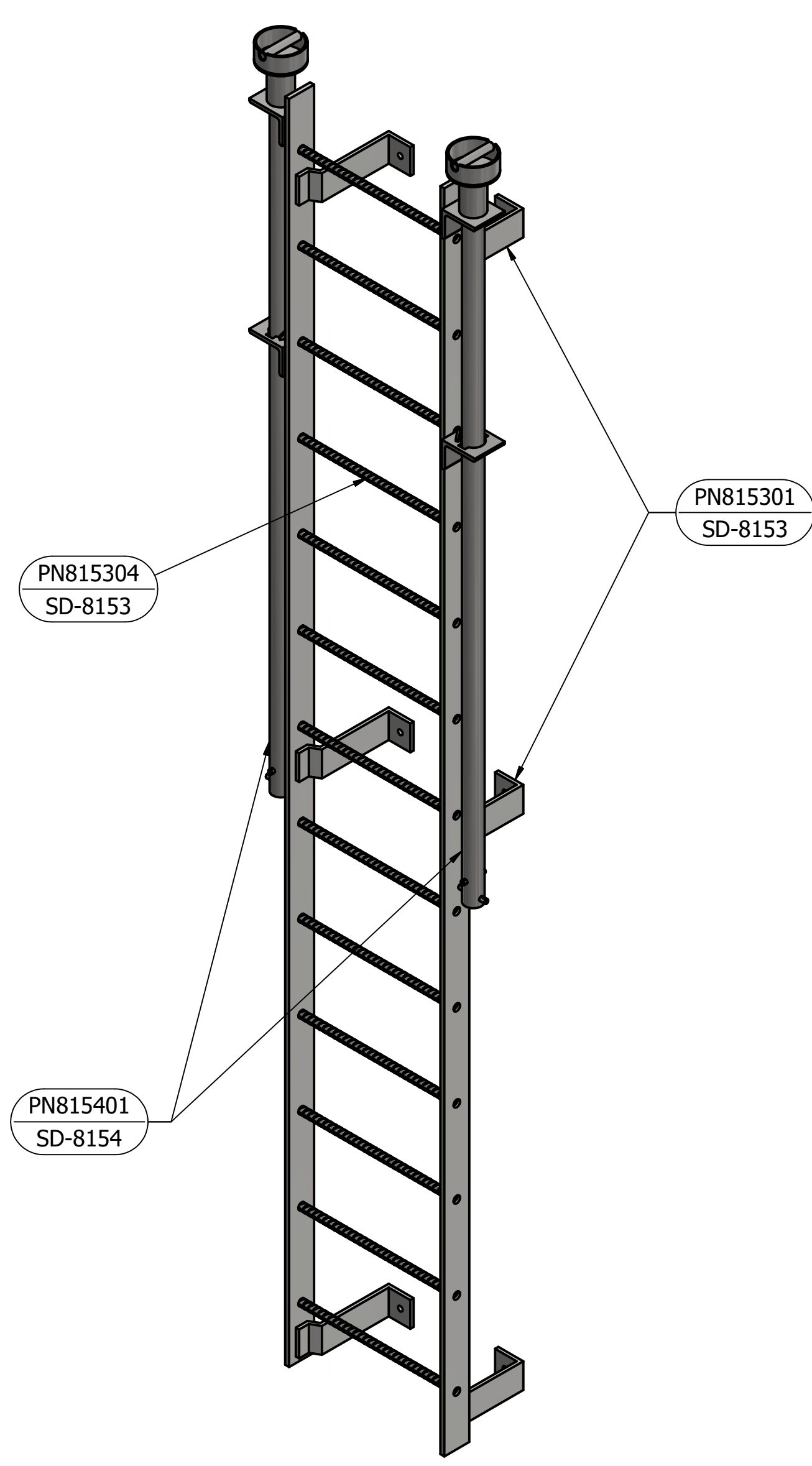

**VERTICAL RUNG LADDER WITH PULL-UP STANCHIONS  
TYPICAL ASSEMBLY**  
SCALE: 1 : 10

MATERIAL: CARBON STEEL  
COATING: HOT DIP GALVANISED  
FINISH COLOUR: N/A  
MASS: DESIGNER TO PROVIDE PROJECT SPECIFIC DETAILS

PARTS LIST				
PART NUMBER	DESCRIPTION	QTY	MASS	REFERENCE
PN815301	WALL BRACKET	6	2 kg	SD-8153
PN815304	LADDER RUNG	13	1 kg	SD-8153
PN815401	EXTENDABLE STANCHION	2	11 kg	SD-8154

ITEM	AMDT.
PN810201	

No.	ISSUE	DATE	DRAWN	CHECKED	AUTHORISED
A	INITIAL ISSUE	15/06/2018	M. Matuziak	K. Danenbergsons	D. Eager

DAM	RES	SPS
BWS	WAT	STP
WTP	SEW	
WPS	REC	
ASSET AREA APPLICABILITY		



STANDARD DRAWING  
HOT DIP GALVANISED STEEL LADDERS  
FIXED VERTICAL RUNG LADDER WITH PULL-UP STANCHIONS  
ASSEMBLY AND DETAILS

DRAWING STATUS	
Current	
SD-8102-D	
A1	ISSUE A
© Icon Water 2017	



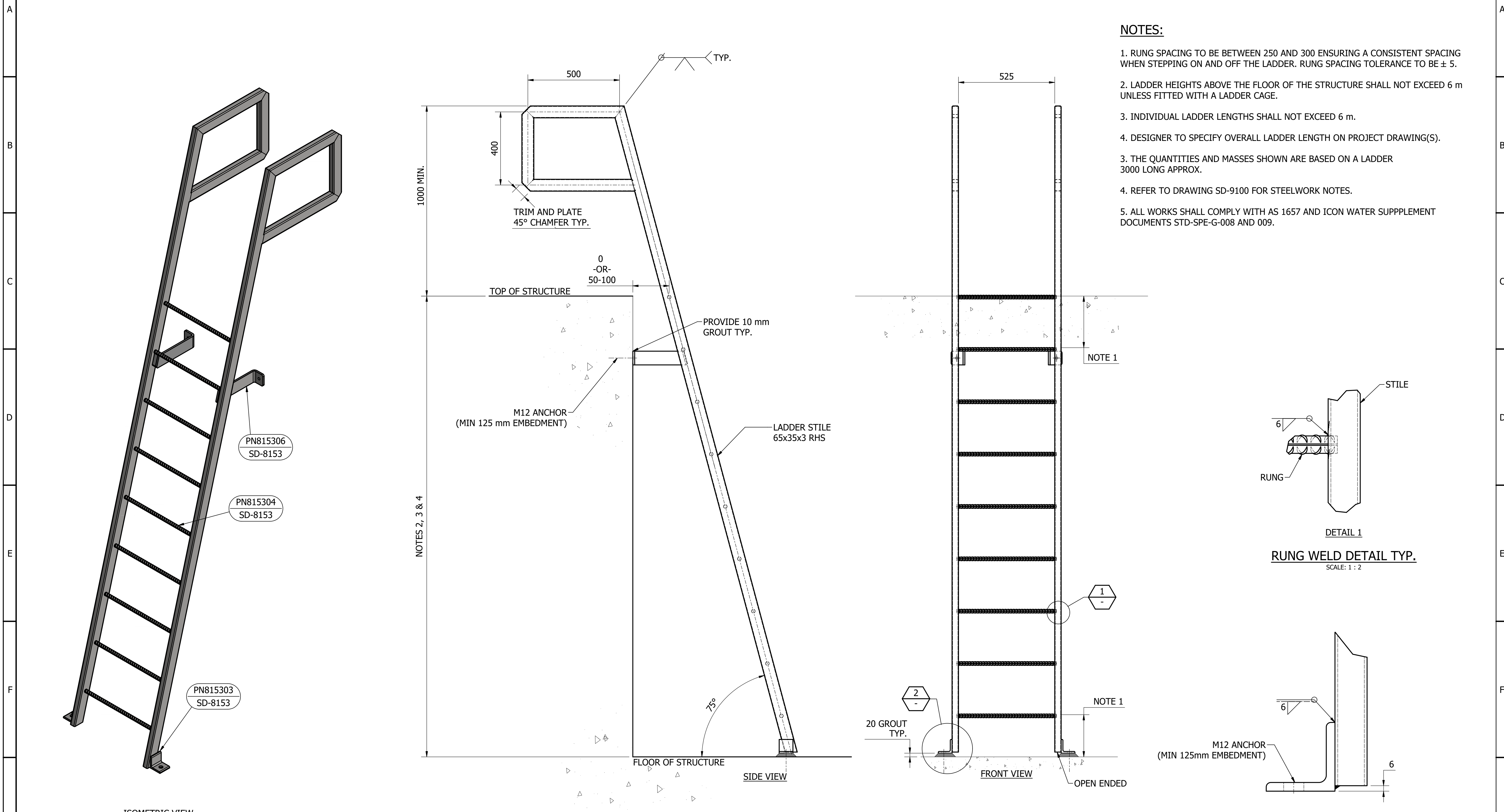

- NOTES:**
1. RUNG SPACING TO BE BETWEEN 250 AND 300 ENSURING A CONSISTENT SPACING WHEN STEPPING ON AND OFF THE LADDER. RUNG SPACING TOLERANCE TO BE ± 5.
  2. LADDER HEIGHTS ABOVE THE FLOOR OF THE STRUCTURE SHALL NOT EXCEED 6 m UNLESS FITTED WITH A LADDER CAGE.
  3. INDIVIDUAL LADDER LENGTHS SHALL NOT EXCEED 6 m.
  4. DESIGNER TO SPECIFY OVERALL LADDER LENGTH ON PROJECT DRAWING(S).
  3. THE QUANTITIES AND MASSES SHOWN ARE BASED ON A LADDER 3000 LONG APPROX.
  4. REFER TO DRAWING SD-9100 FOR STEELWORK NOTES.
  5. ALL WORKS SHALL COMPLY WITH AS 1657 AND ICON WATER SUPPLEMENT DOCUMENTS STD-SPE-G-008 AND 009.

PARTS LIST				
PART NUMBER	DESCRIPTION	QTY	MASS	REFERENCE
N/A	LADDER STILES	2	22.1 kg	SD-8103
PN815304	LADDER RUNG	9	1.2 kg	SD-8153
PN815306	WALL BRACKET	2	2.2 kg	SD-8153
PN815303	FLOOR BRACKET	2	.8 kg	SD-8153

**FIXED INCLINED RUNG LADDER WITH FIXED STANCHIONS - TYPICAL ASSEMBLY**  
 SCALE : 1 : 10  
 MATERIAL: CARBON STEEL  
 COATING: HOT DIP GALVANISED  
 FINISH COLOUR: N/A  
 MASS: 60 kg

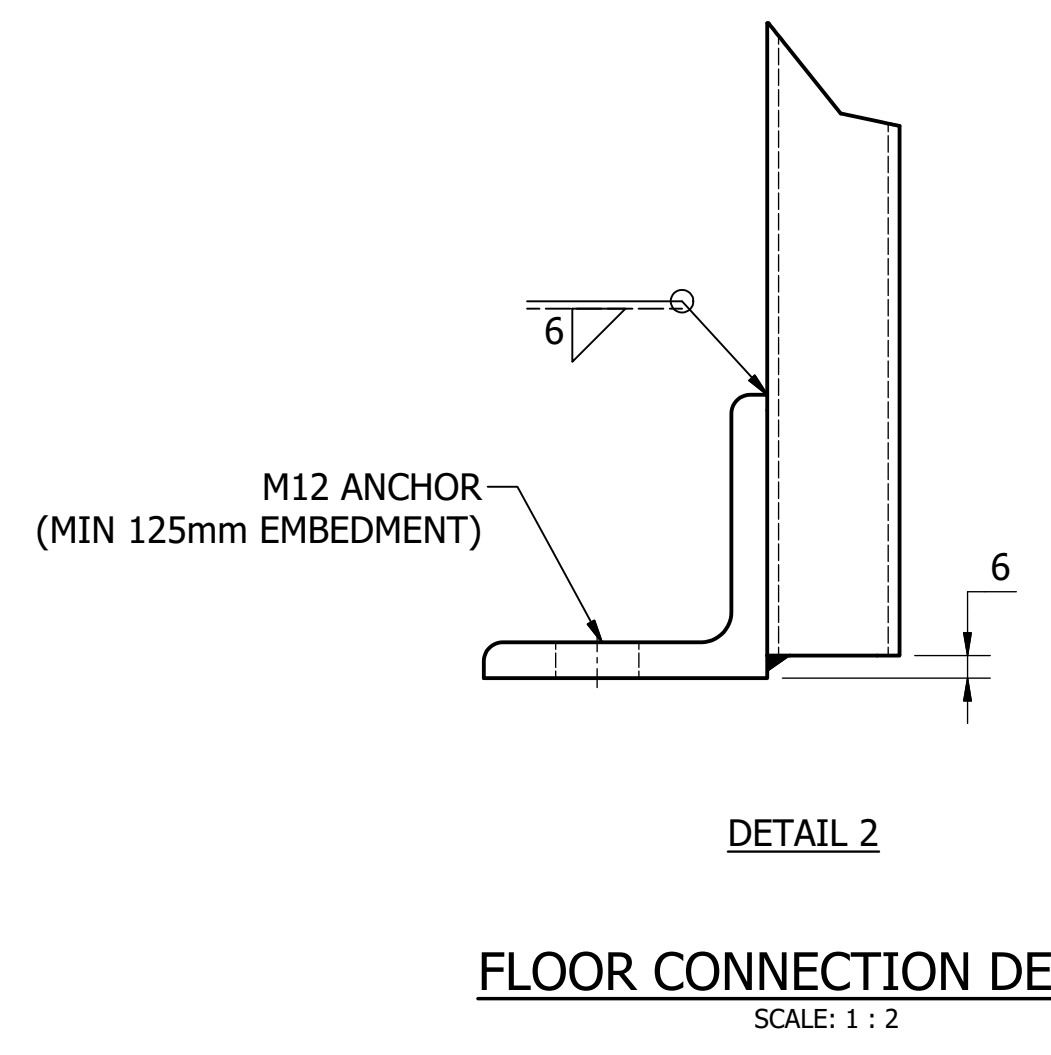
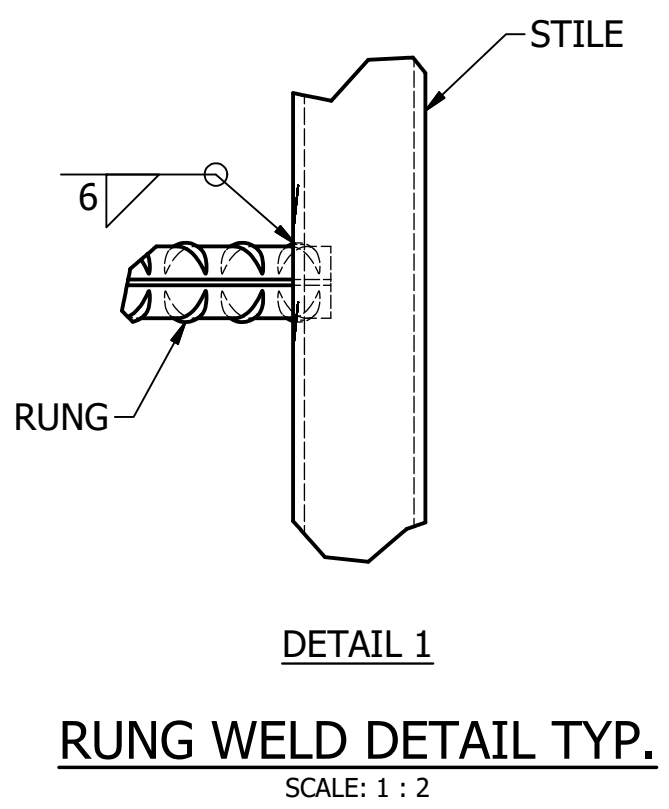

ITEM	AMDT.
PN810301	

No.	ISSUE	DATE	DRAWN	CHECKED	AUTHORISED
A	INITIAL ISSUE	15/06/2018	S. Essery	K. Danenbergsons	D. Eager

DAM	RES	SPS
BWS	WAT	STP
WTP	SEW	
WPS	REC	



STANDARD DRAWING  
 HOT DIP GALVANISED STEEL LADDERS  
 FIXED INCLINED RUNG LADDER WITH FIXED STANCHIONS  
 ASSEMBLY AND DETAILS

DRAWING STATUS	
Current	
SD-8103-D	
A1	ISSUE A

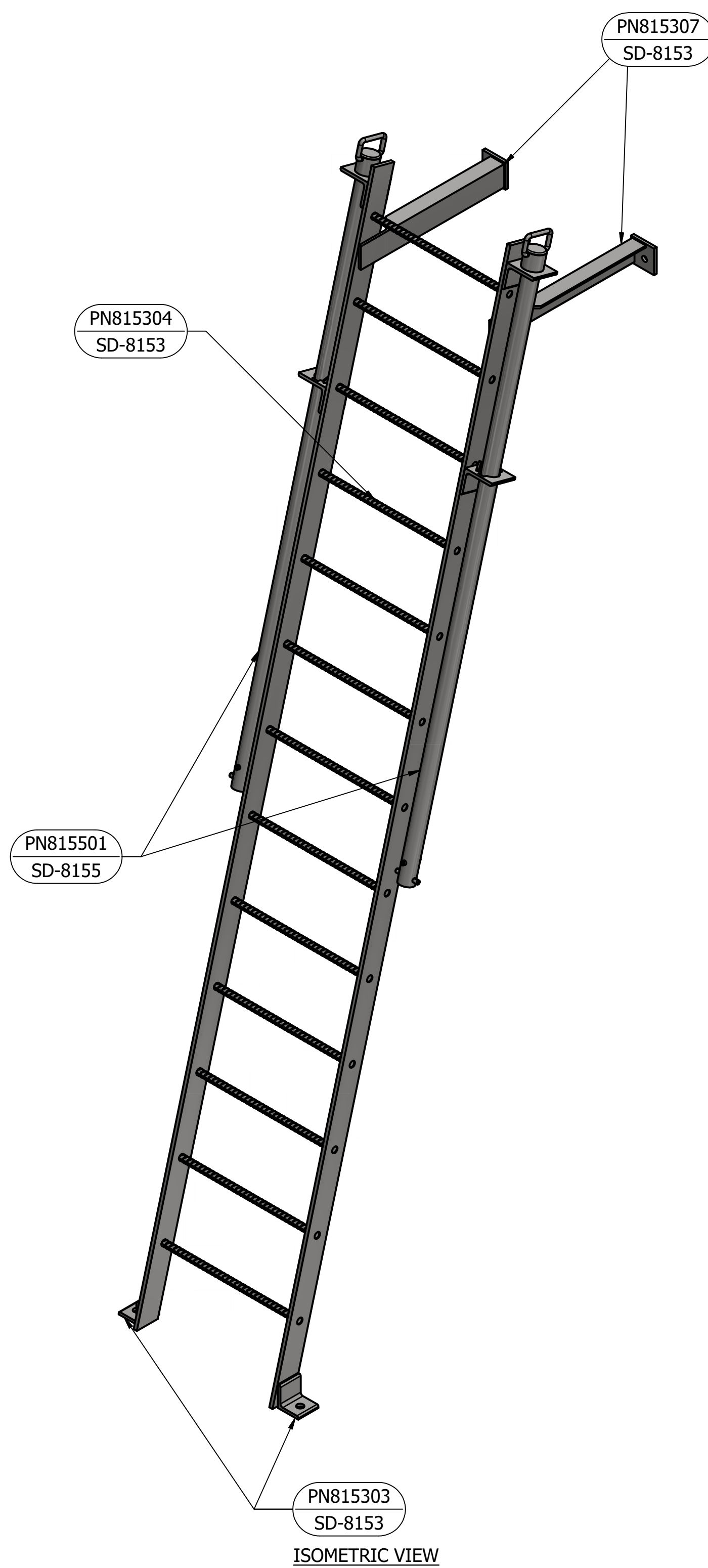

ISOMETRIC VIEW

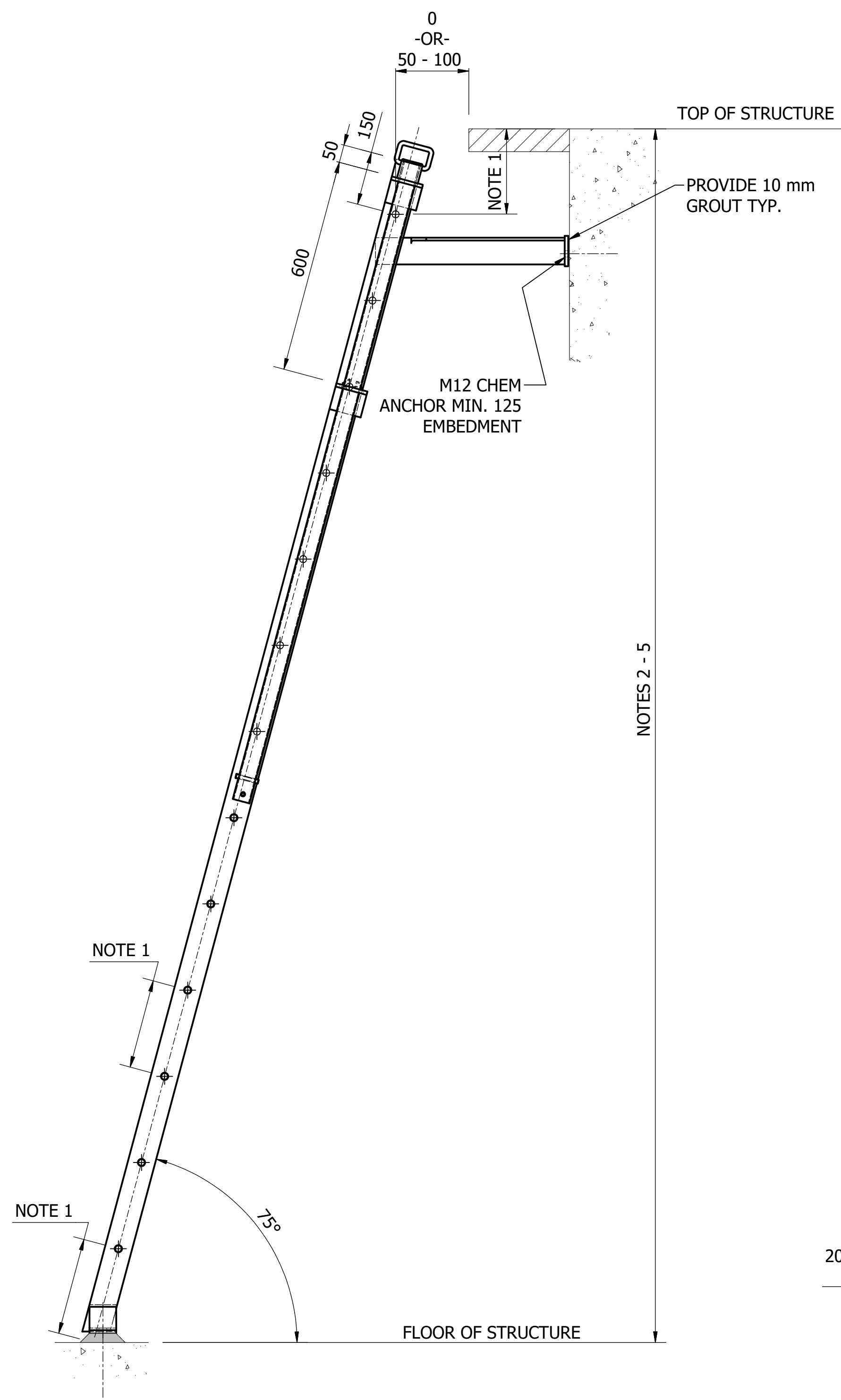

SIDE VIEW

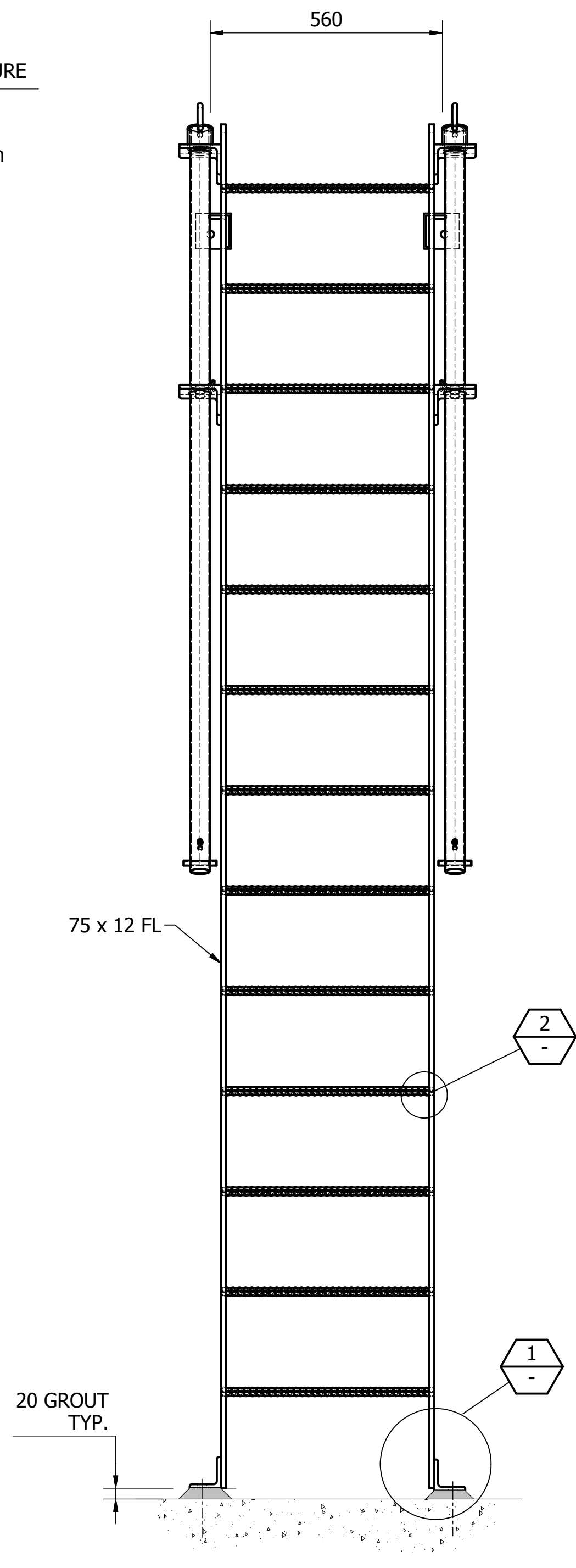

FRONT VIEW

**NOTES:**

1. THE DESIGNER SHALL NOMINATE AN EVEN RUNG PITCH BETWEEN 250 AND 300 ENSURING A CONSISTENT PITCH WHEN STEPPING ON & OFF THE LADDER. RUNG PITCH TOLERANCE SHALL BE ±5.
2. LADDER HEIGHTS ABOVE THE FLOOR OF THE STRUCTURE SHALL NOT EXCEED 6 m UNLESS FITTED WITH A LADDER CAGE.
3. INDIVIDUAL LADDER LENGTHS SHALL NOT EXCEED 6 m.
4. THE QUANTITIES AND MASSES SHOWN ARE BASED ON A LADDER 3000 LONG.
5. DESIGNER TO SPECIFY OVERALL LADDER LENGTH ON PROJECT DRAWING(S).
6. THIS LADDER IS COMPATIBLE WITH THE ACCESS HATCHES SHOWN ON SD-8201, SD-8211 AND SD-8234.
7. REFER TO DRAWING SD-9100 FOR STEELWORK NOTES.
8. ALL WORKS SHALL COMPLY WITH AS 1657 AND ICON WATER SUPPLEMENT DOCUMENTS STD-SPE-G-008 AND 009.

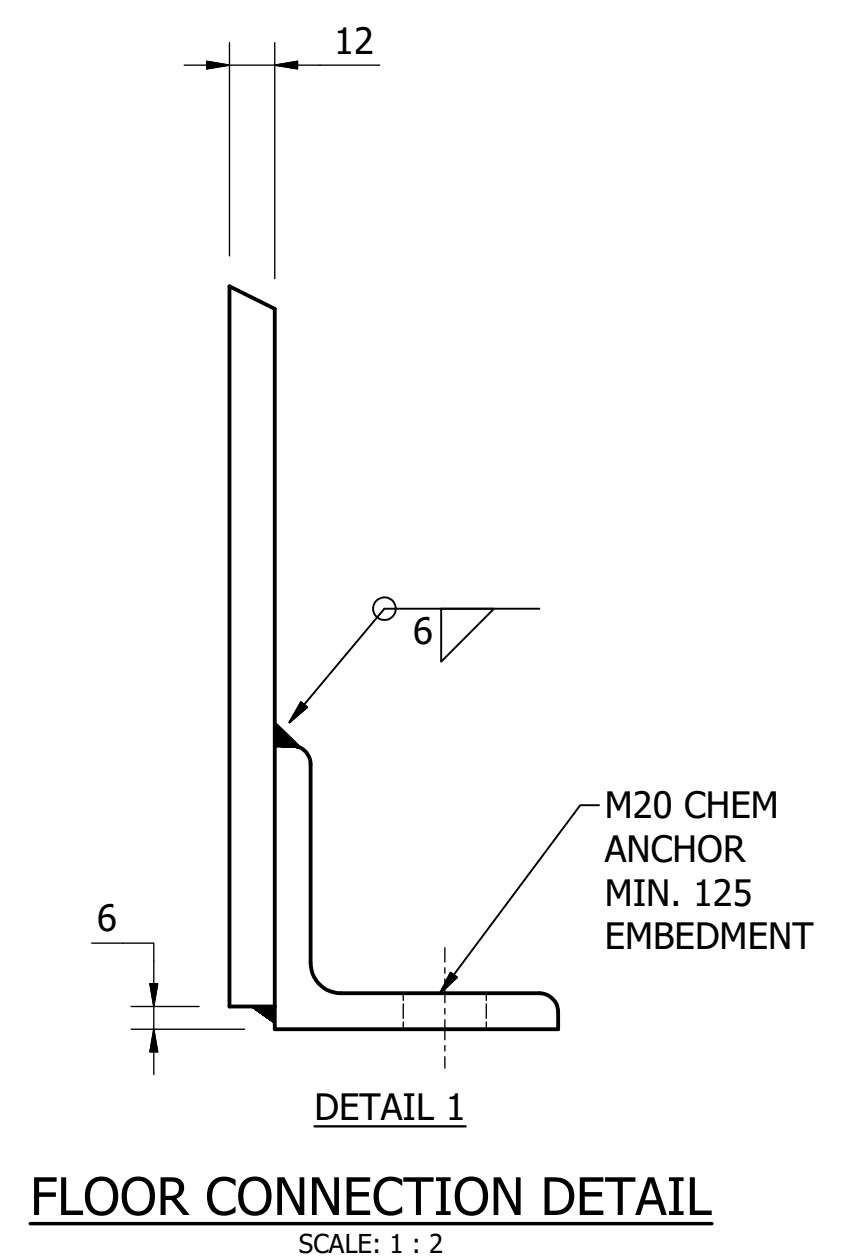

DETAIL 1  
FLOOR CONNECTION DETAIL  
SCALE: 1 : 2

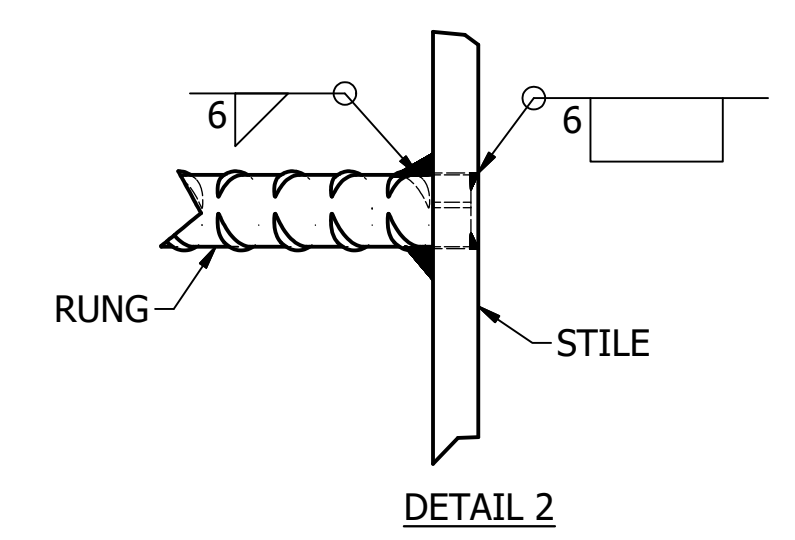

DETAIL 2  
RUNG WELD DETAIL TYP.  
SCALE: 1 : 2

**INCLINED RUNG LADDER WITH PULL-UP STANCHIONS  
TYPICAL ASSEMBLY**  
SCALE : 1 : 10

MATERIAL: CARBON STEEL  
COATING: HOT DIP GALVANISED  
FINISH COLOUR: N/A  
MASS: DESIGNER TO PROVIDE PROJECT SPECIFIC DETAILS

PARTS LIST				
PART NUMBER	DESCRIPTION	QTY	MASS	REFERENCE
PN815304	LADDER RUNG	13	1 kg	SD-8153
PN815501	EXTENDABLE STANCHIONS	2	10 kg	SD-8155
PN815303	FLOOR BRACKET	2	1 kg	SD-8153
PN815307	WALL BRACKET	2	2 kg	SD-8153

ITEM	AMDT.
PN810401	

No.	ISSUE	DATE	DRAWN	CHECKED	AUTHORISED
A	INITIAL ISSUE	15/06/2018	S. Essery	K. Danenbergsons	D. Eager

DAM	RES	SPS
BWS	WAT	STP
WTP	SEW	
WPS	REC	



STANDARD DRAWING  
HOT DIP GALVANISED STEEL LADDERS  
FIXED INCLINED RUNG LADDER WITH PULL-UP STANCHIONS  
ARRANGEMENT AND DETAILS

DRAWING STATUS	
Current	
SD-8104-D	
A1	ISSUE A



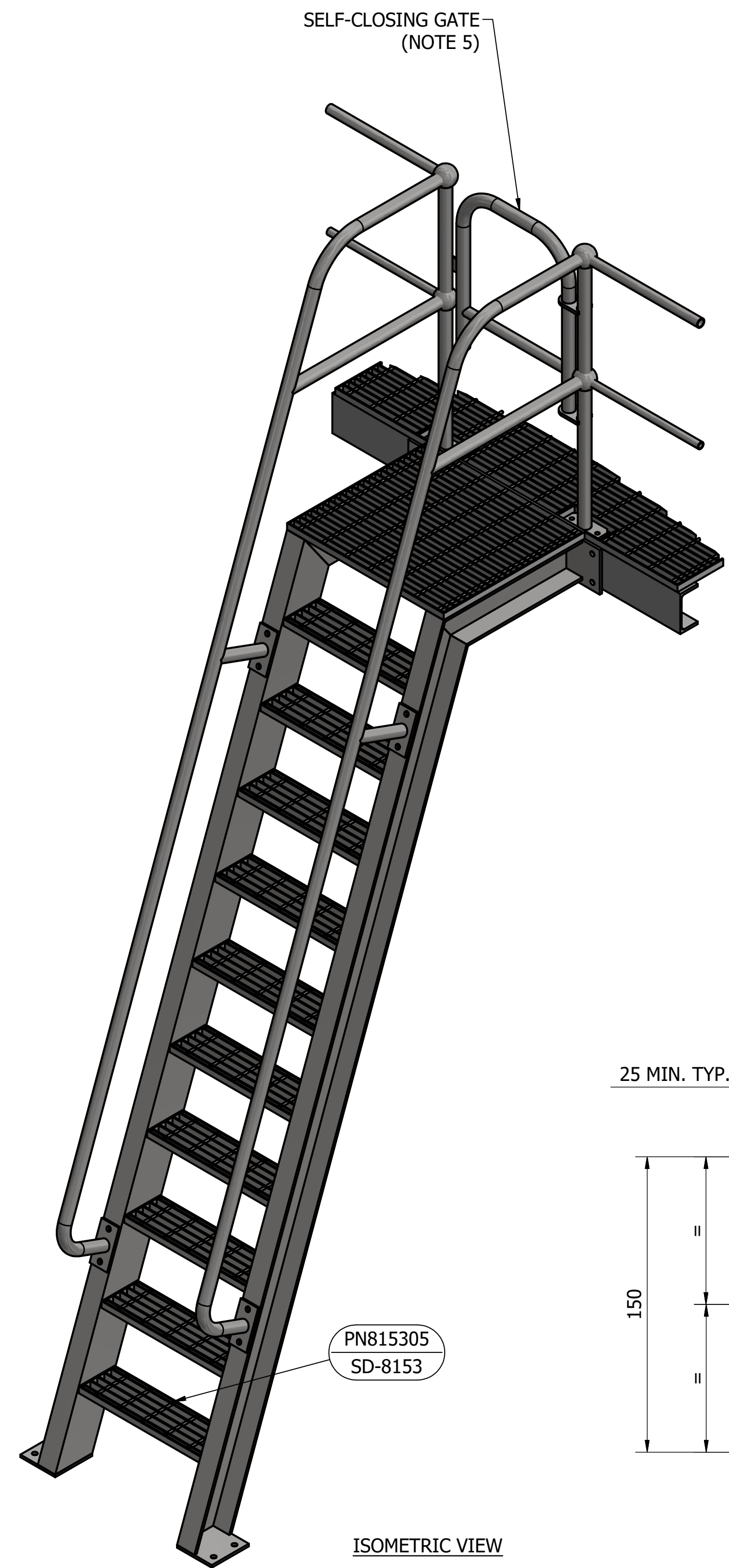

ISOMETRIC VIEW

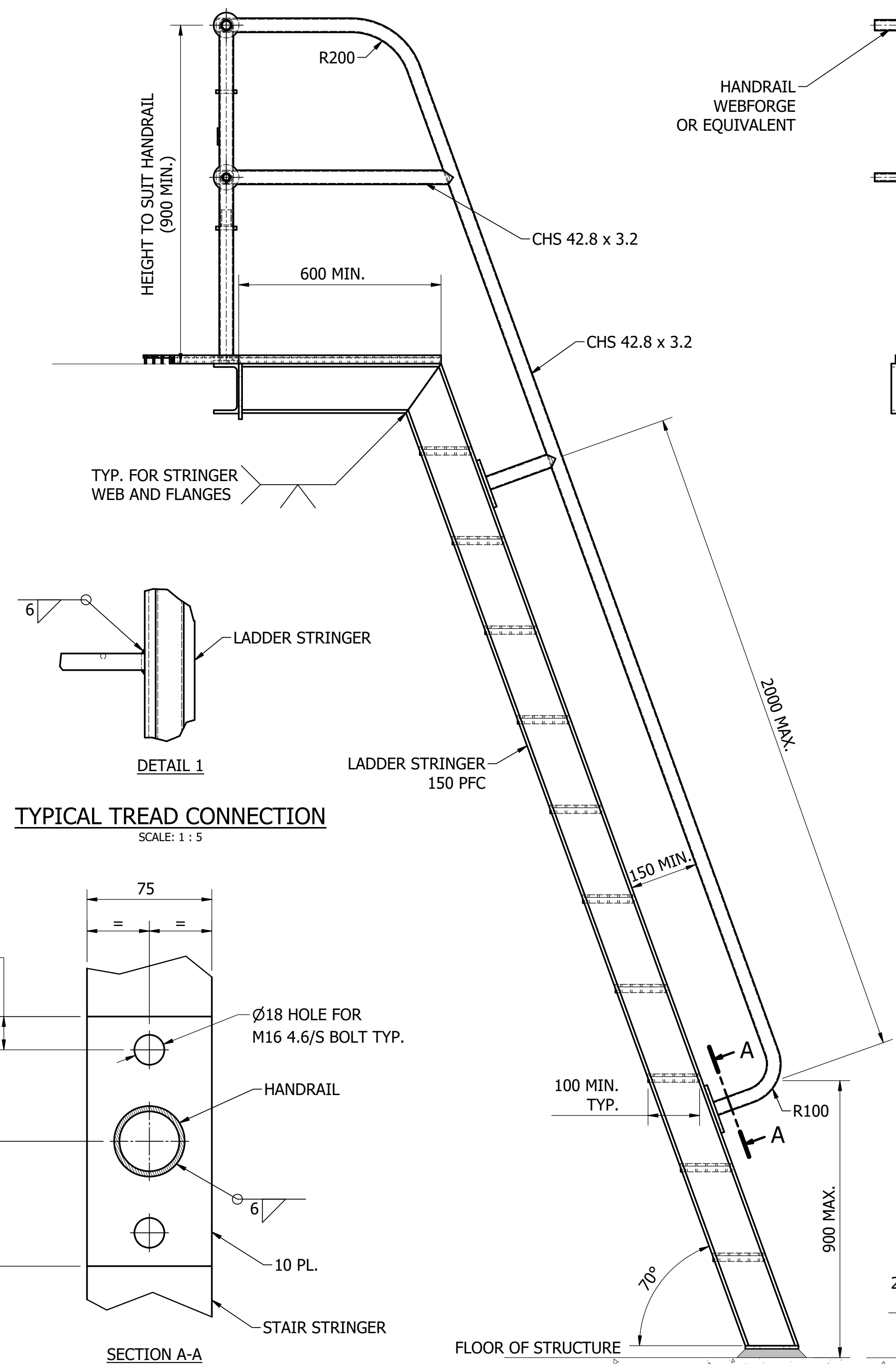

SIDE VIEW

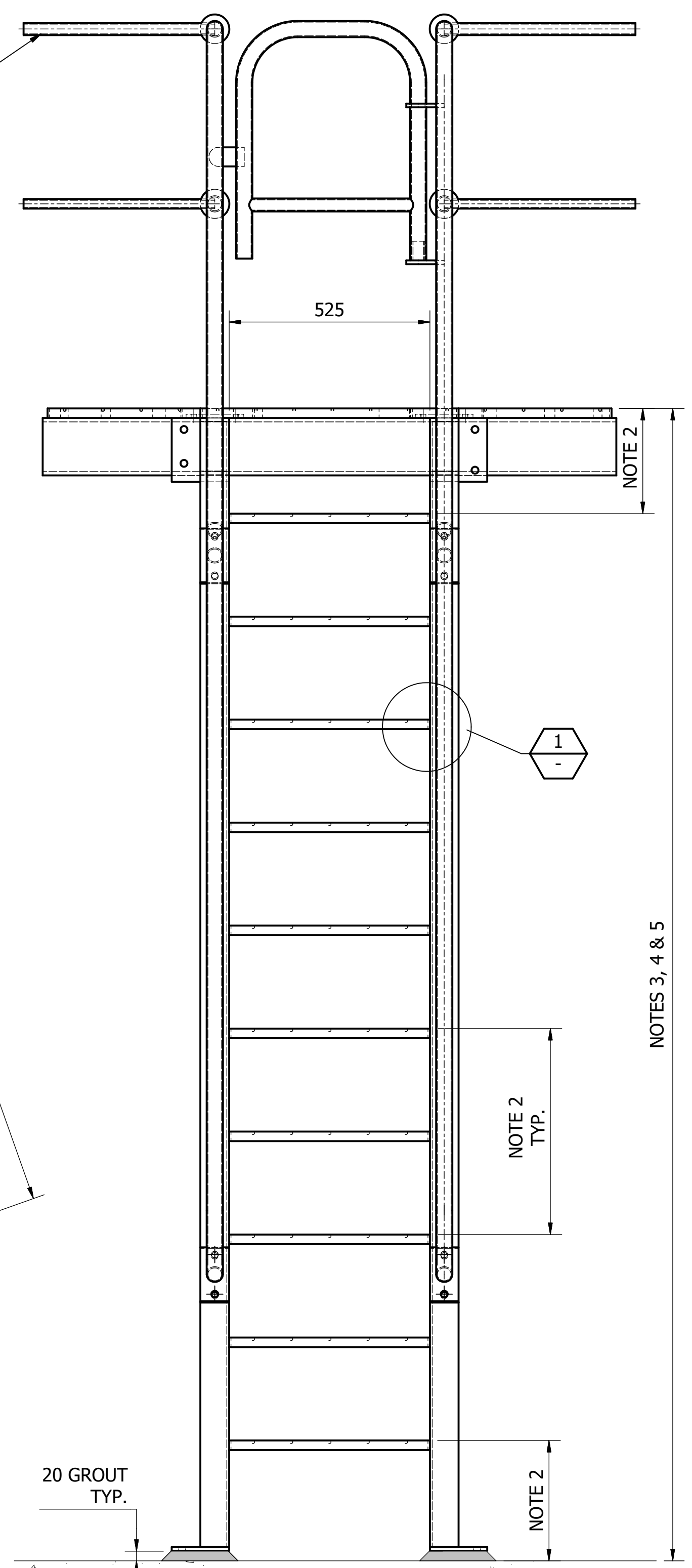

FRONT VIEW

**NOTES:**

- REFER TO DRAWING SD-9100 FOR STEELWORK NOTES.
- TREAD SPACING TO BE BETWEEN 200 AND 300 ENSURING A CONSISTENT SPACING WHEN STEPPING ON & OFF THE STEP LADDER. TREAD SPACING TOLERANCE SHALL BE ± 5.
- LADDER HEIGHTS ABOVE THE FLOOR OF THE STRUCTURE SHALL NOT EXCEED 6 m UNLESS FITTED WITH A LADDER CAGE.
- INDIVIDUAL LADDER LENGTHS SHALL NOT EXCEED 6 m.
- THE LADDER ANGLE, NUMBER OF RUNGS AND OVERALL LADDER LENGTH ETC. SHALL BE NOMINATED BY THE DESIGNER SPECIFICALLY FOR THE PROJECT APPLICATION.
- THE QUANTITIES AND MASSES SHOWN ARE BASED ON A LADDER 3000 LONG.
- SELF CLOSING GATE TO BE "WEBFORGE" MONOWILLS OR APPROVED EQUIVALENT. GATE TO OPEN AWAY FROM LADDER. SPECIFY SWING DIRECTION, CLEAR OPENING AND LOCKING REQUIREMENTS AS PER "WEBFORGE" CATALOGUE.
- ALL WORKS SHALL COMPLY WITH AS 1657 AND ICON WATER SUPPLEMENT DOCUMENTS STD-SPE-G-008 AND 009.

NOTES 3, 4 & 5

**STEP LADDER HANDRAIL CONNECTION**  
SCALE: 1 : 2

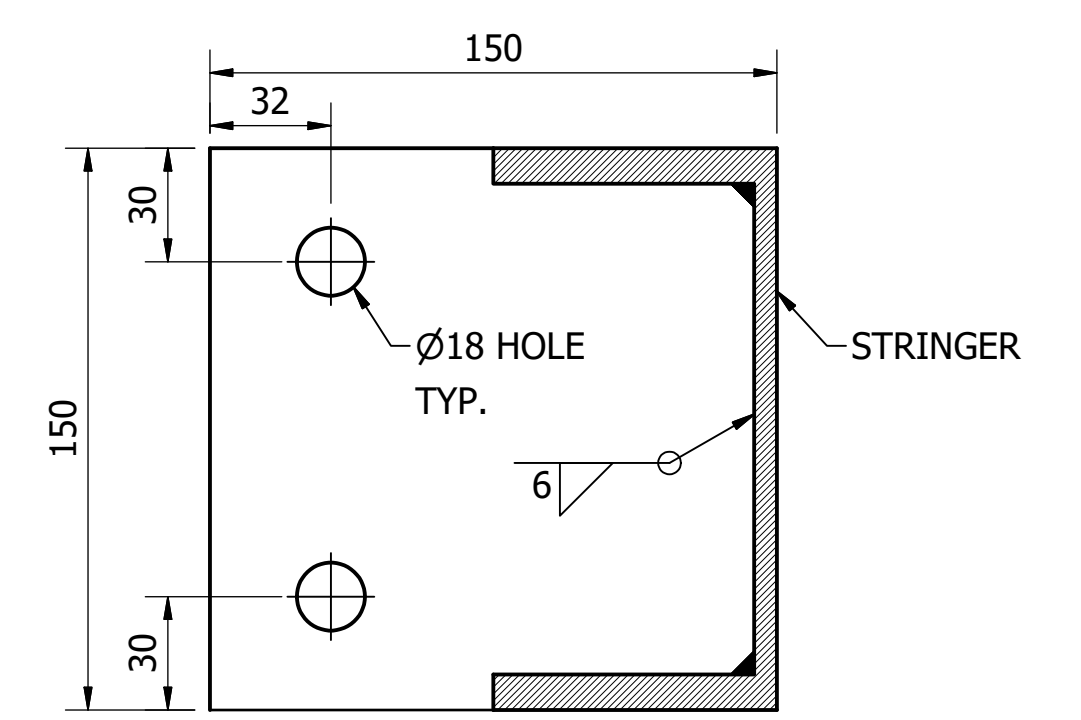
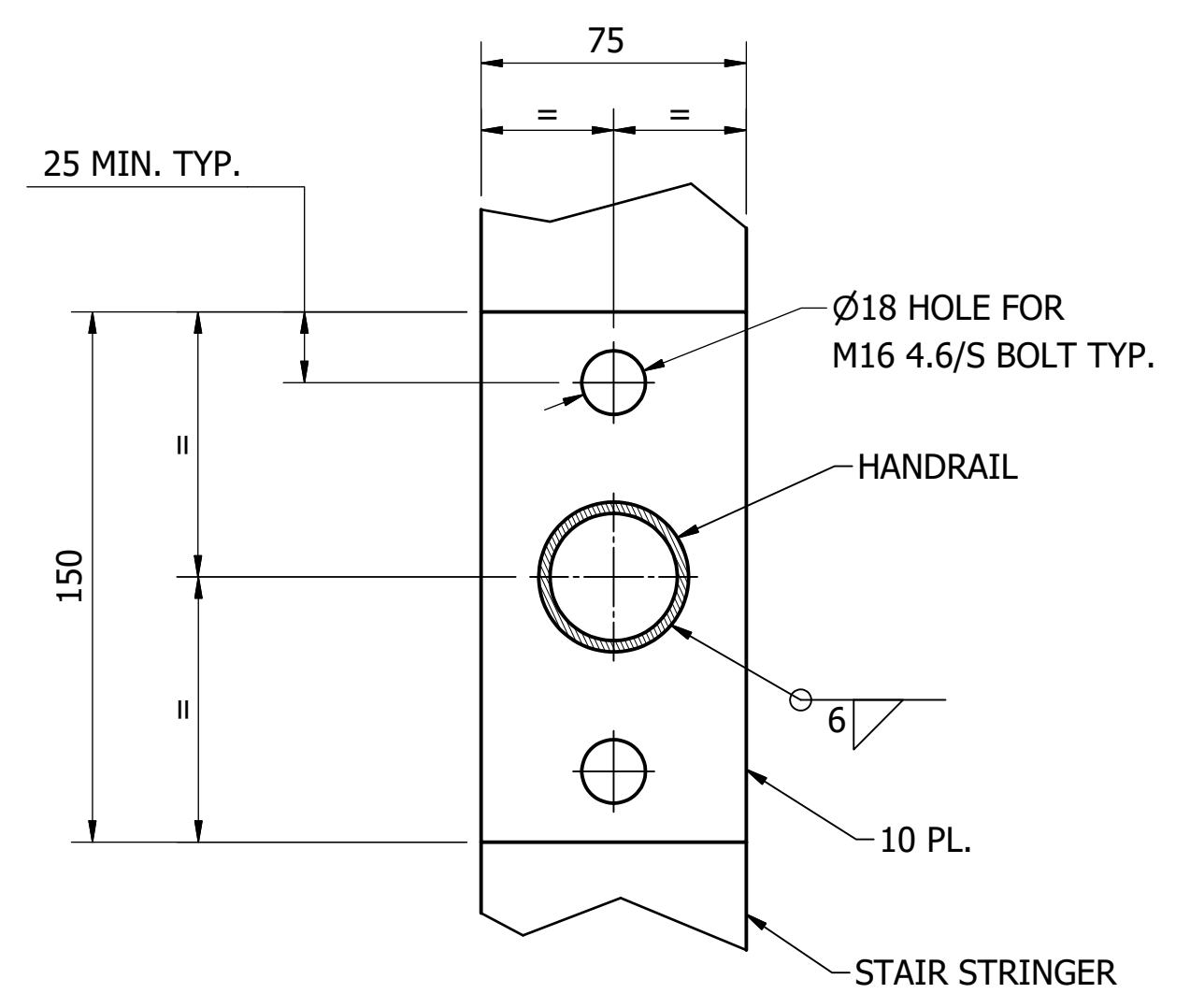

**TOP BRACKET**  
SCALE: 1 : 2

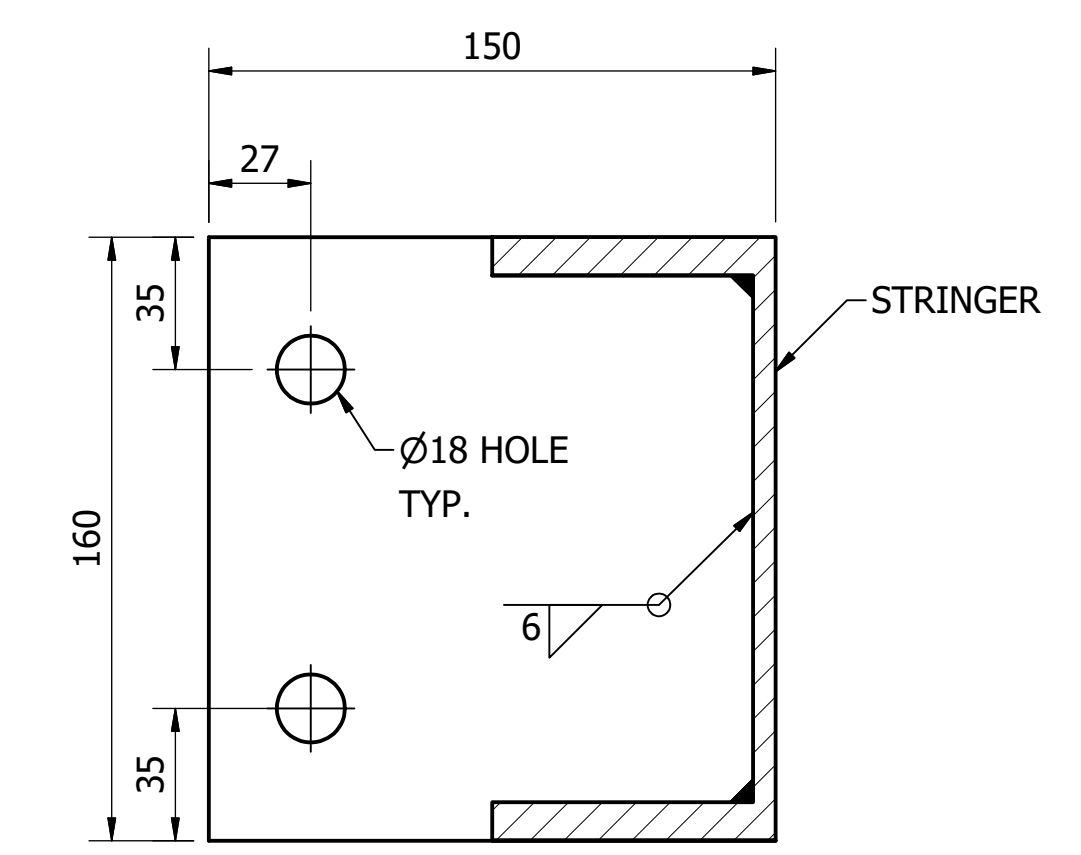

**BOTTOM BRACKET**  
SCALE: 1 : 2

**INCLINED STEP LADDER WITH FIXED STANCHIONS**  
**TYPICAL ARRANGEMENT**  
SCALE: 1 : 10

MATERIAL: CARBON STEEL  
COATING: HOT DIP GALVANISED  
FINISH COLOUR: N/A  
MASS: 200 kg @ 3 m LENGTH

PARTS LIST				
PART NUMBER	DESCRIPTION	QTY	MASS	REFERENCE
N/A	LADDER STRINGER	2	64 kg	
PN815305	LADDER TREAD	11	4.1 kg	SD-8153
N/A	HANDRAIL	2	12 kg	

ITEM	AMDT.
PN810501	

No.	ISSUE	DATE	DRAWN	CHECKED	AUTHORISED
A	INITIAL ISSUE	15/06/2018	K. Patel	K. Danenbergs	D. Eager

DAM	RES	SPS
BWS	WAT	STP
WTP	SEW	
WPS	REC	



STANDARD DRAWING  
HOT DIP GALVANISED STEEL LADDERS  
FIXED INCLINED STEP LADDER  
FIXED STANCHIONS  
ARRANGEMENTS AND DETAILS

DRAWING STATUS	
Current	
SD-8105-D	
A1	ISSUE A



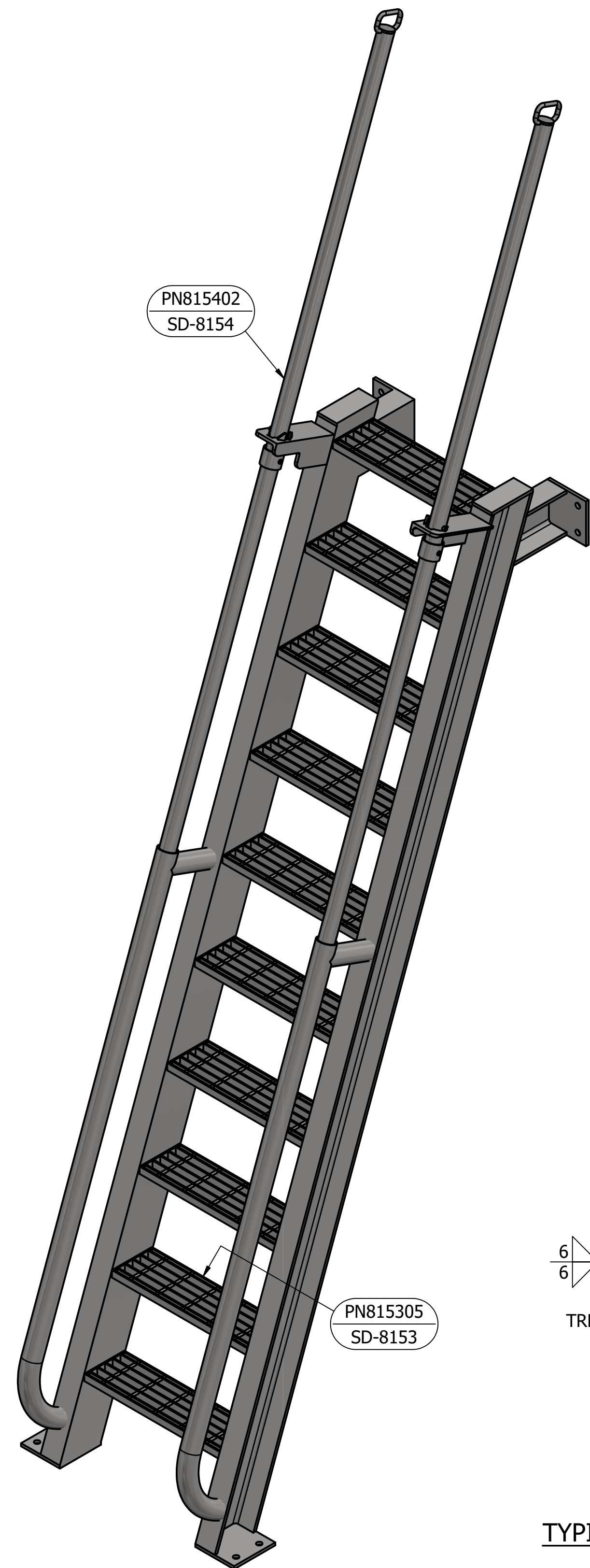

PN815402  
SD-8154

PN815305  
SD-8153

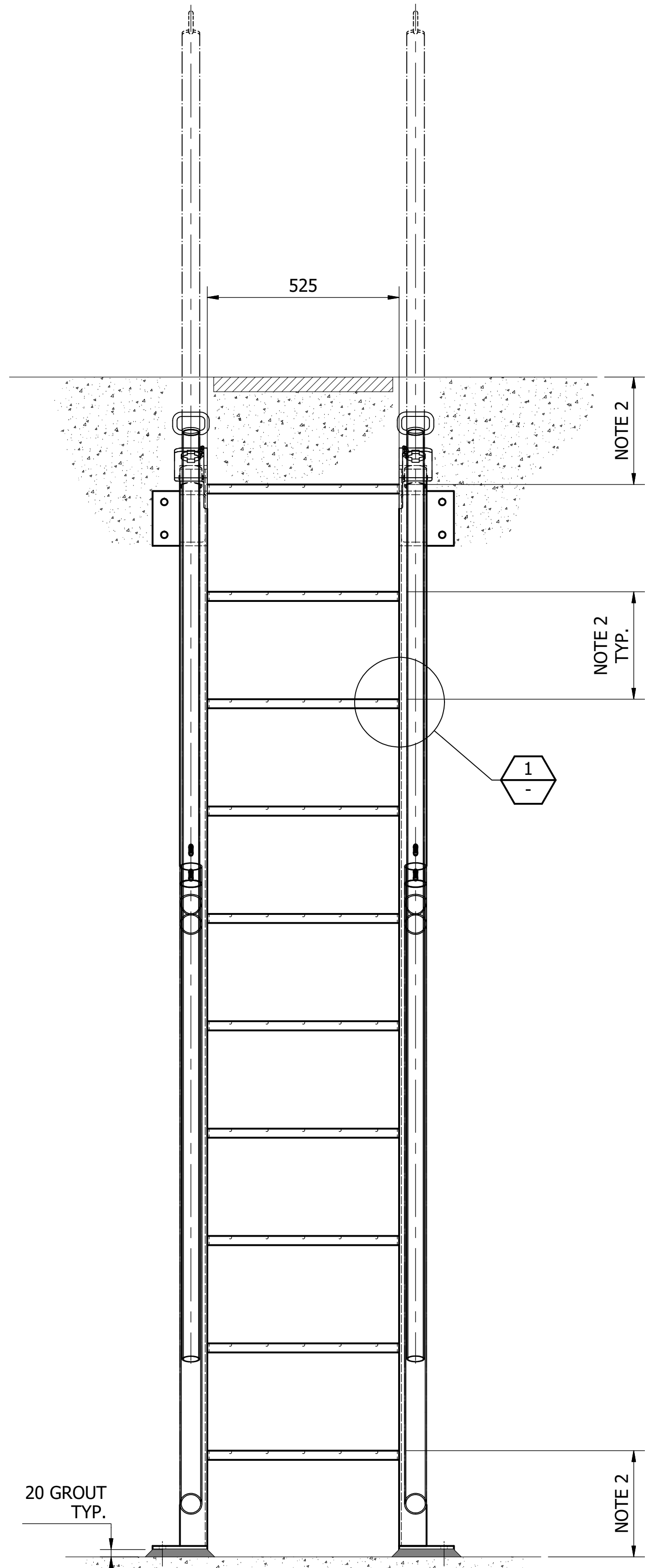
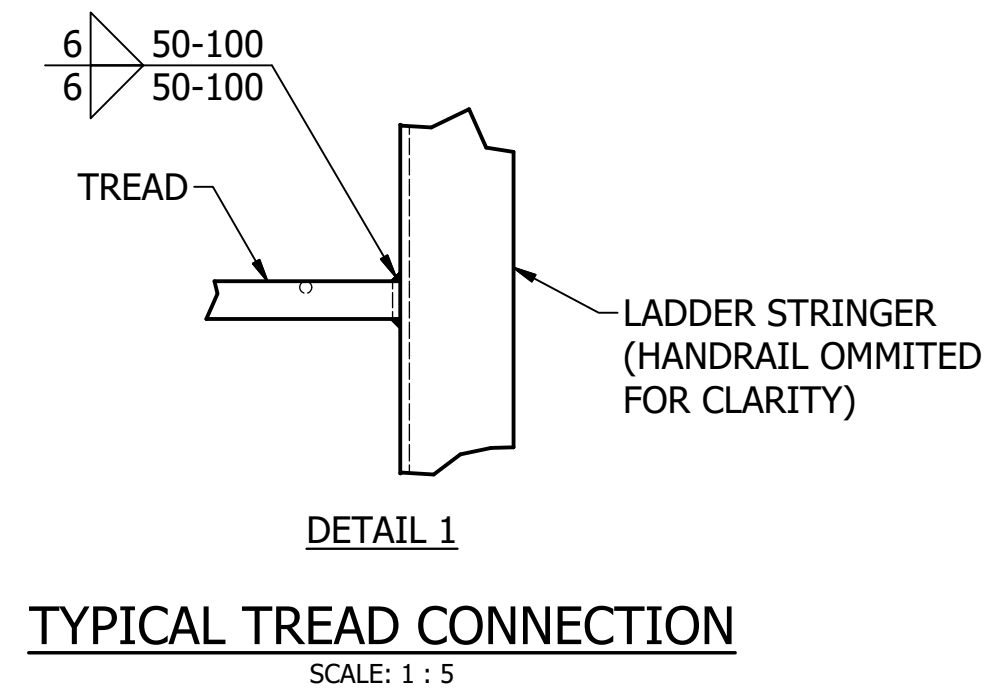
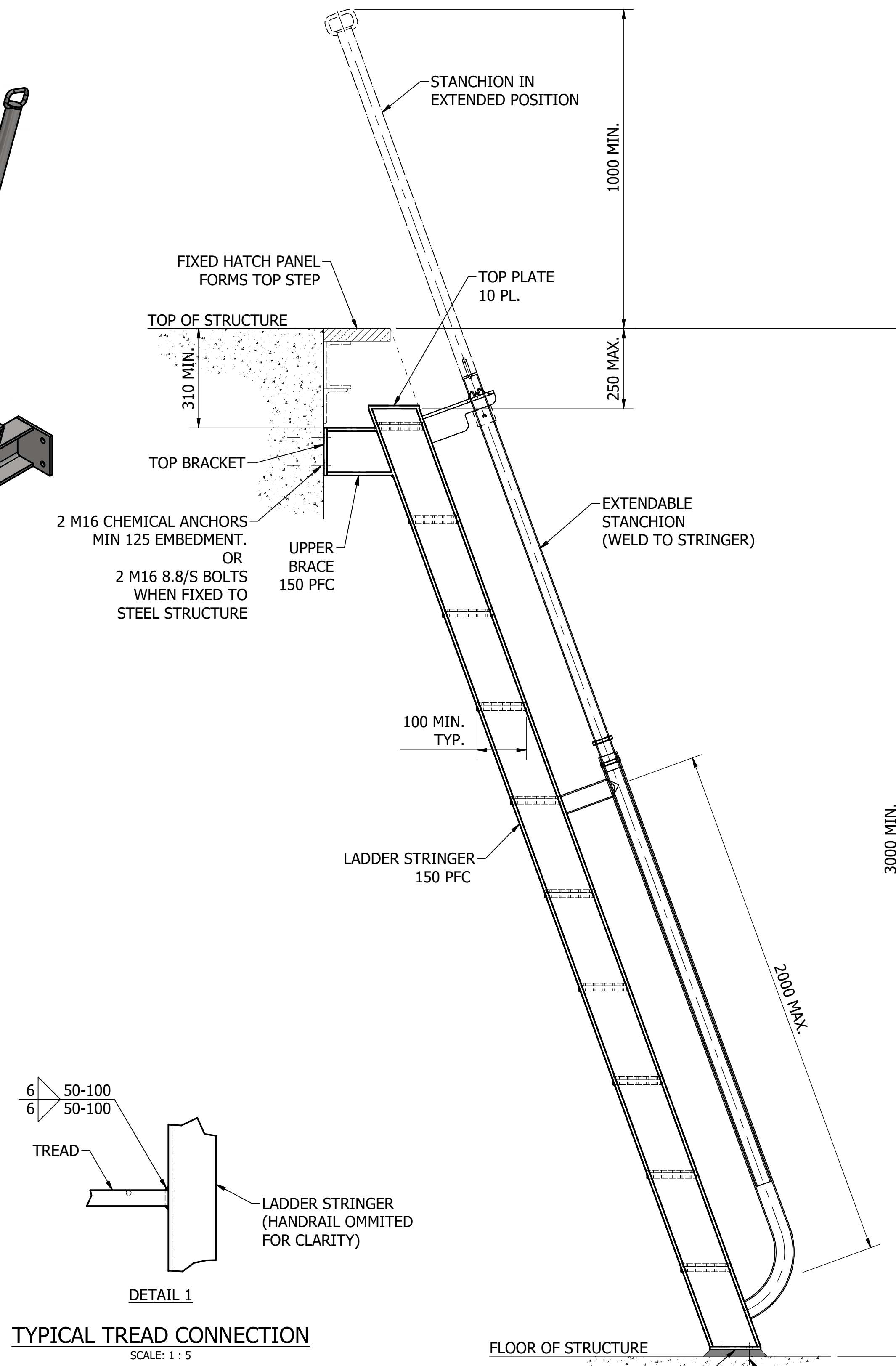

- NOTES:**
- REFER TO DRAWING SD-9100 FOR STEELWORK NOTES.
  - TREAD SPACING TO BE BETWEEN 200 AND 300 ENSURING A CONSISTENT SPACING WHEN STEPPING ON & OFF THE STEP LADDER. TREAD SPACING TOLERANCE SHALL BE  $\pm 5$ .
  - THE LADDER ANGLE, NUMBER OF RUNGS, SPACING OFF WALL AND OVERALL LADDER LENGTH ETC. SHALL BE NOMINATED BY THE DESIGNER SPECIFICALLY FOR THE PROJECT APPLICATION.
  - LADDER HEIGHTS ABOVE THE FLOOR OF THE STRUCTURE SHALL NOT EXCEED 6 m UNLESS FITTED WITH A LADDER CAGE.
  - INDIVIDUAL LADDER LENGTHS SHALL NOT EXCEED 6 m.
  - THIS LADDER IS COMPATIBLE WITH THE ACCESS HATCH SHOWN ON SD-8234.
  - QUANTITY AND MASS BASED ON A LADDER APPROX 3000 IN LENGTH.
  - ALL WORKS SHALL COMPLY WITH AS 1657 AND ICON WATER SUPPLEMENT DOCUMENTS STD-SPE-G-008 AND 009.

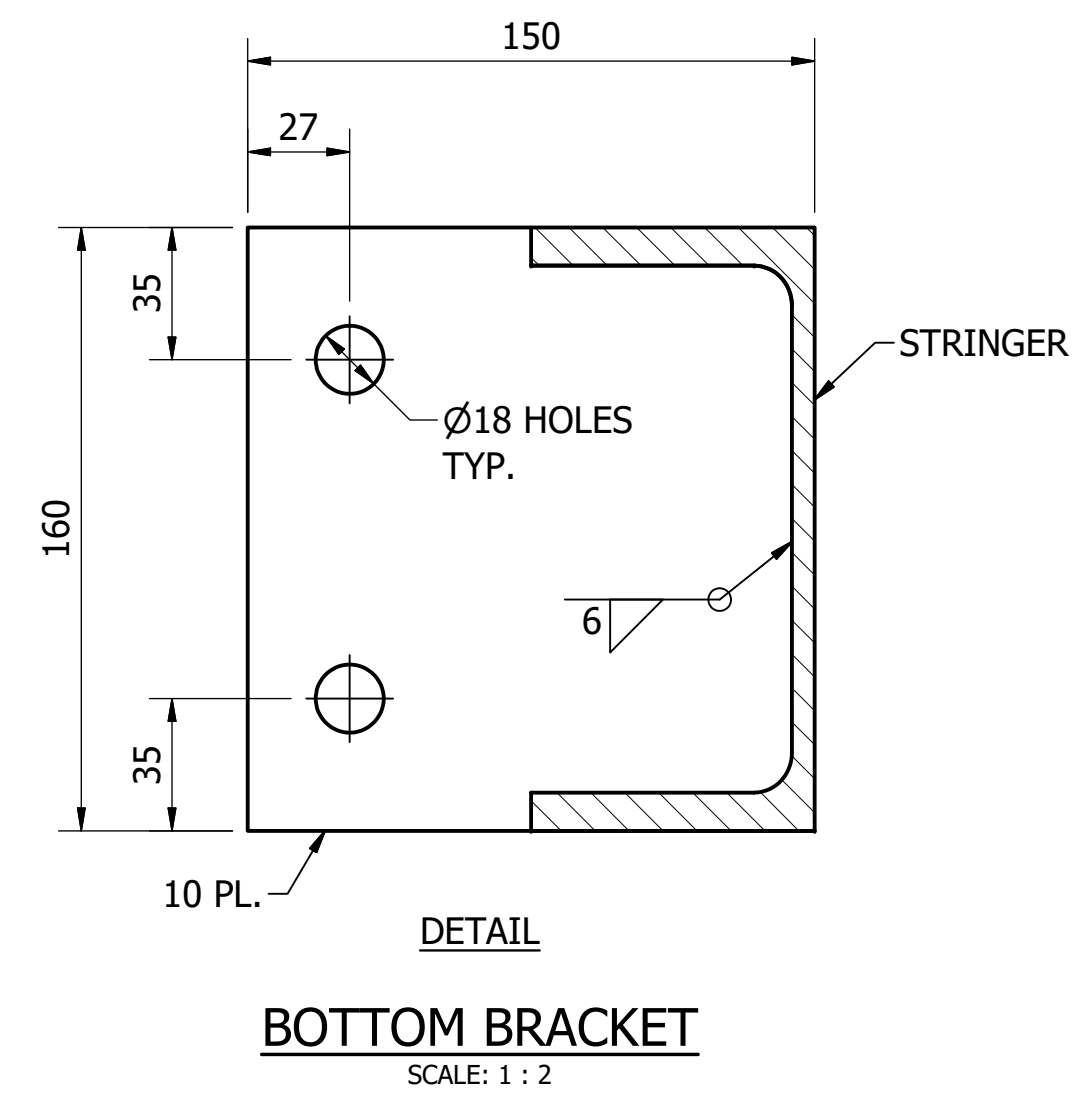
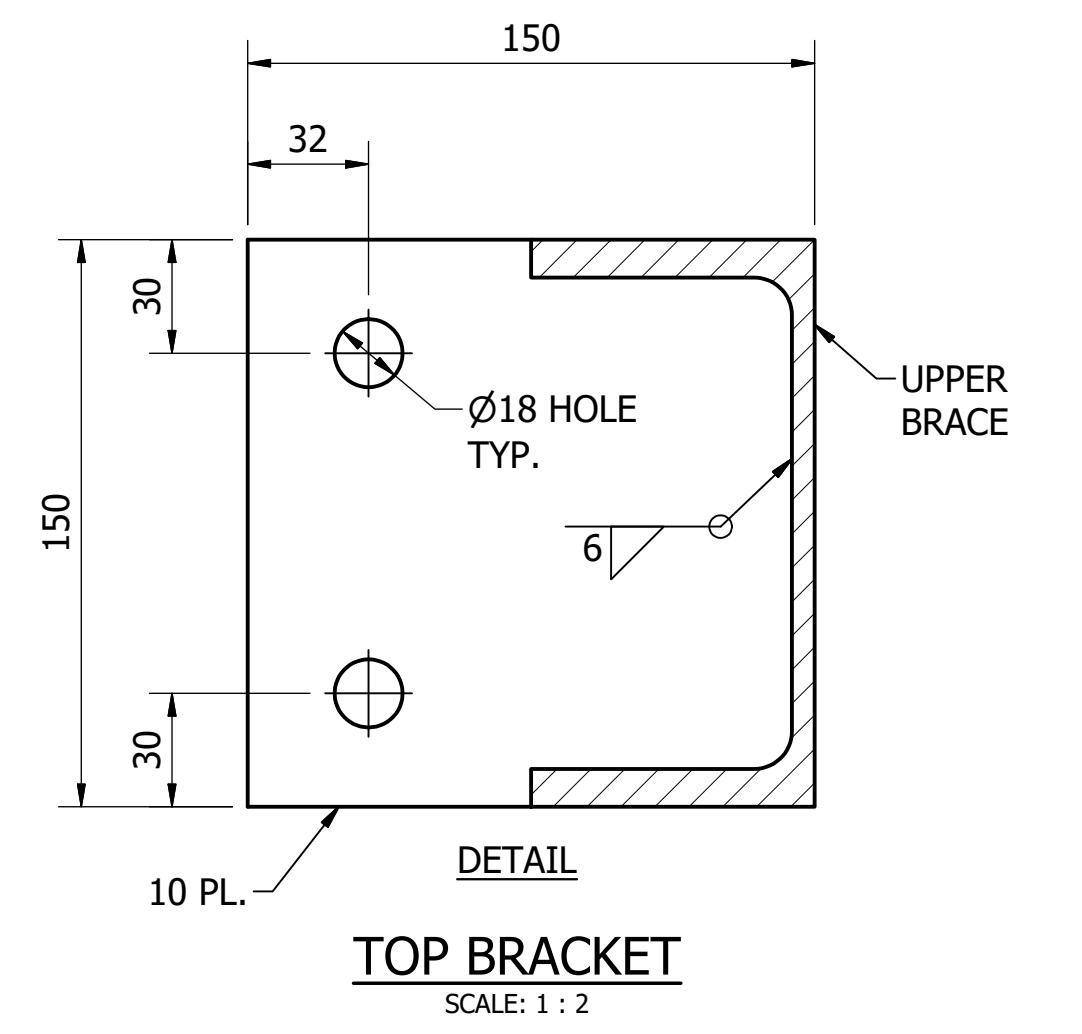

PARTS LIST				
PART NUMBER	DESCRIPTION	QTY	MASS	REFERENCE
N/A	LADDER STRINGER	2	64 kg	SD-8106
PN815305	LADDER TREAD	10	4.1 kg	SD-8153
PN815402	EXTENDABLE STANCHION	2	22.7 kg	SD-8154

**INCLINED STEP LADDER WITH EXTENDABLE STANCHIONS  
TYPICAL ARRANGEMENT**

MATERIAL: CARBON STEEL  
COATING: HOT DIP GALVANISED  
FINISH COLOUR: N/A  
MASS: 200 kg @ 3 m LENGTH

ITEM	AMDT.
PN810601	

No.	ISSUE	DATE	DRAWN	CHECKED	AUTHORISED
A	INITIAL ISSUE	15/06/2018	M. Matusiak	K. Danenbergsons	D. Eager

DAM	RES	SPS
BWS	WAT	STP
WTP	SEW	
WPS	REC	



STANDARD DRAWING  
HOT DIP GALVANISED STEEL LADDERS  
FIXED INCLINED STEP LADDER - EXTENDABLE STANCHIONS  
ARRANGEMENT AND DETAILS

DRAWING STATUS	
Current	
SD-8106-D	
A1	ISSUE A



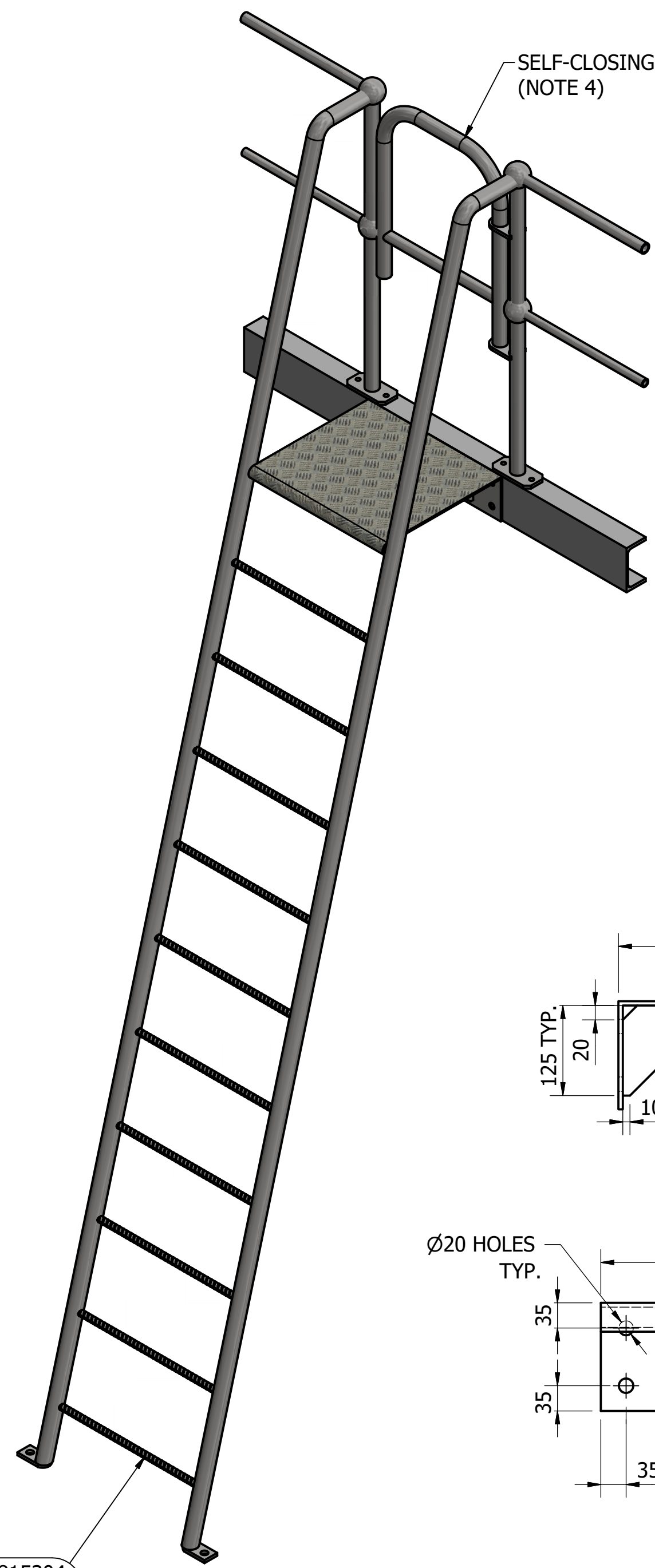

ISOMETRIC VIEW

PN815304  
SD-8153

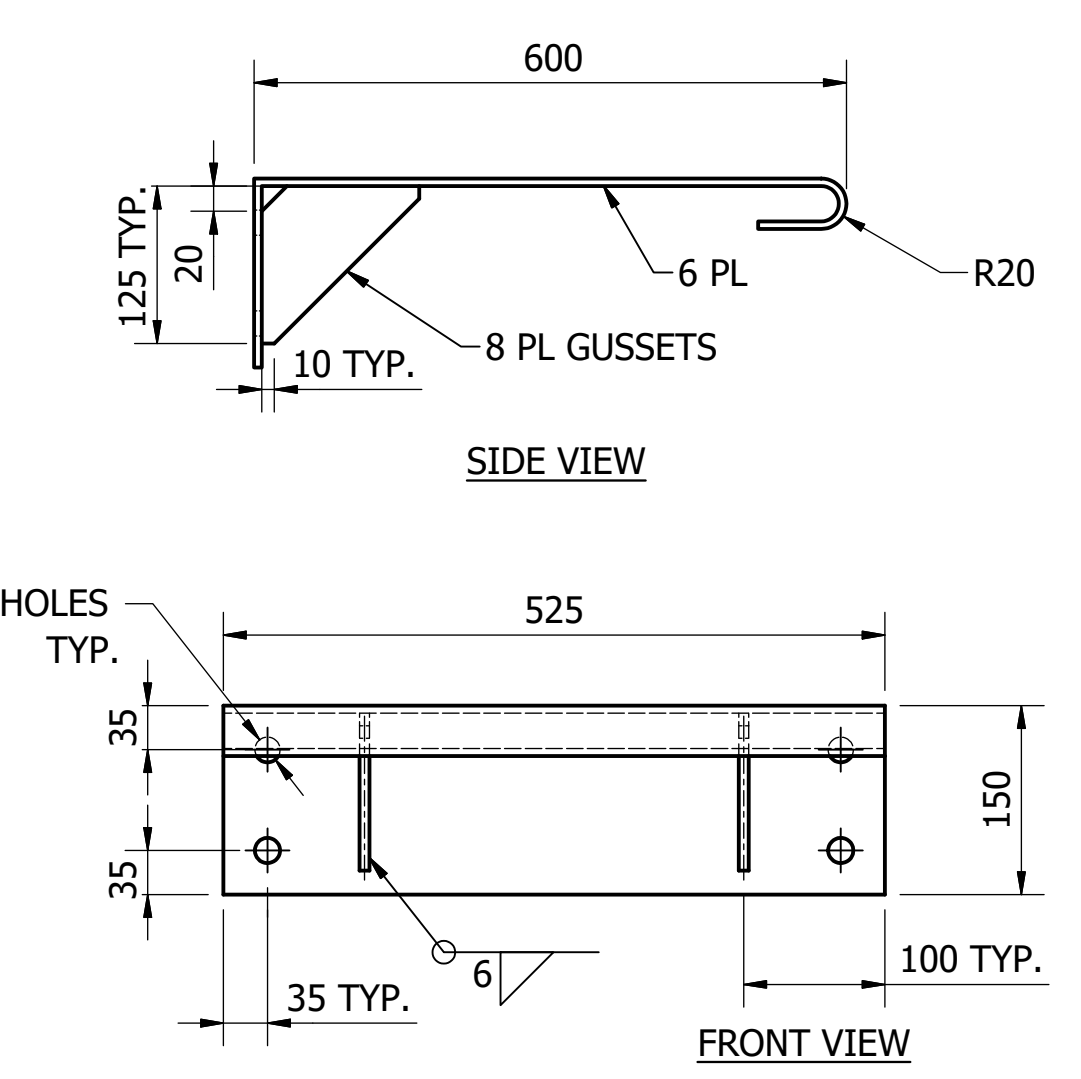

RUNG LADDER LANDING  
SCALE: 1 : 6

PARTS LIST				
PART NUM	DESCRIPTION	QT	MASS	REFERENCE
N/A	LADDER STILE	2	31.2 kg	
N/A	LANDING PLATE	1	19.8 kg	
PN815304	LADDER RUNG	11	1.2 kg	SD-8153

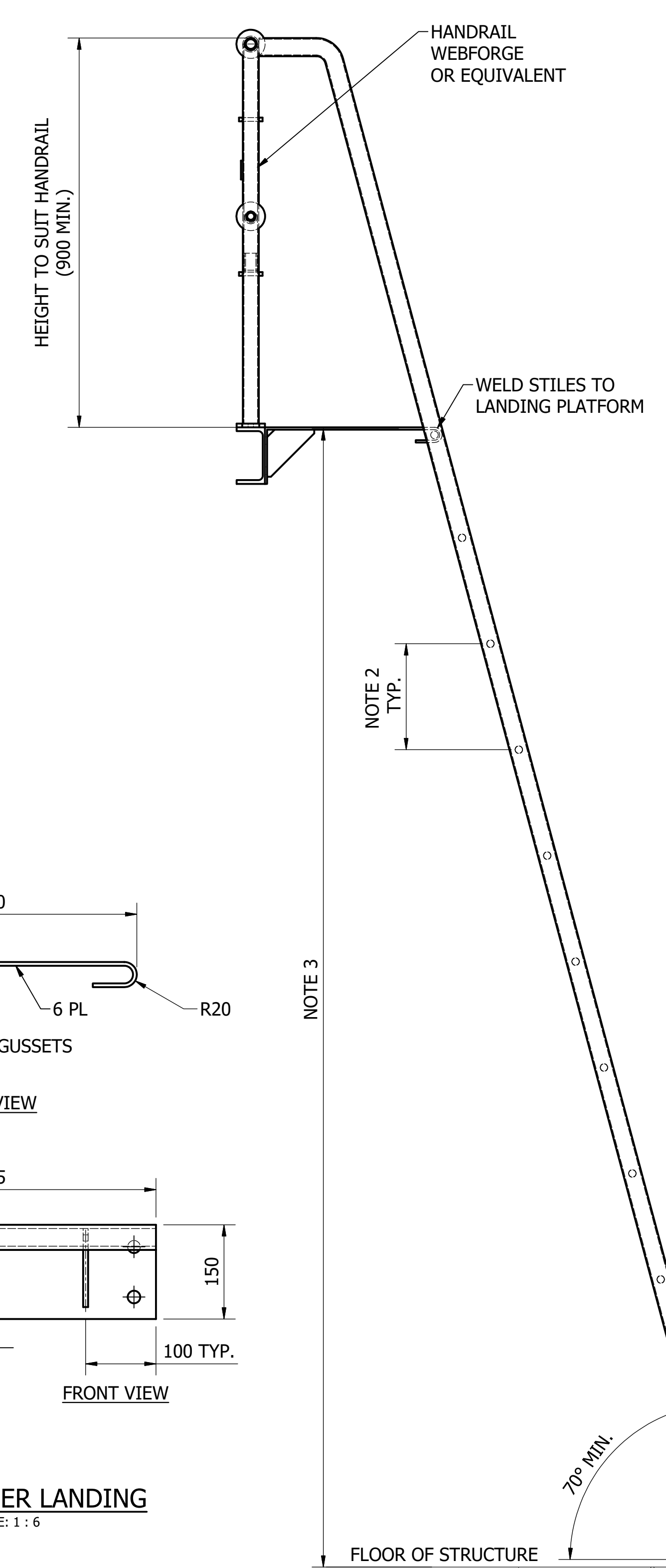

SIDE VIEW

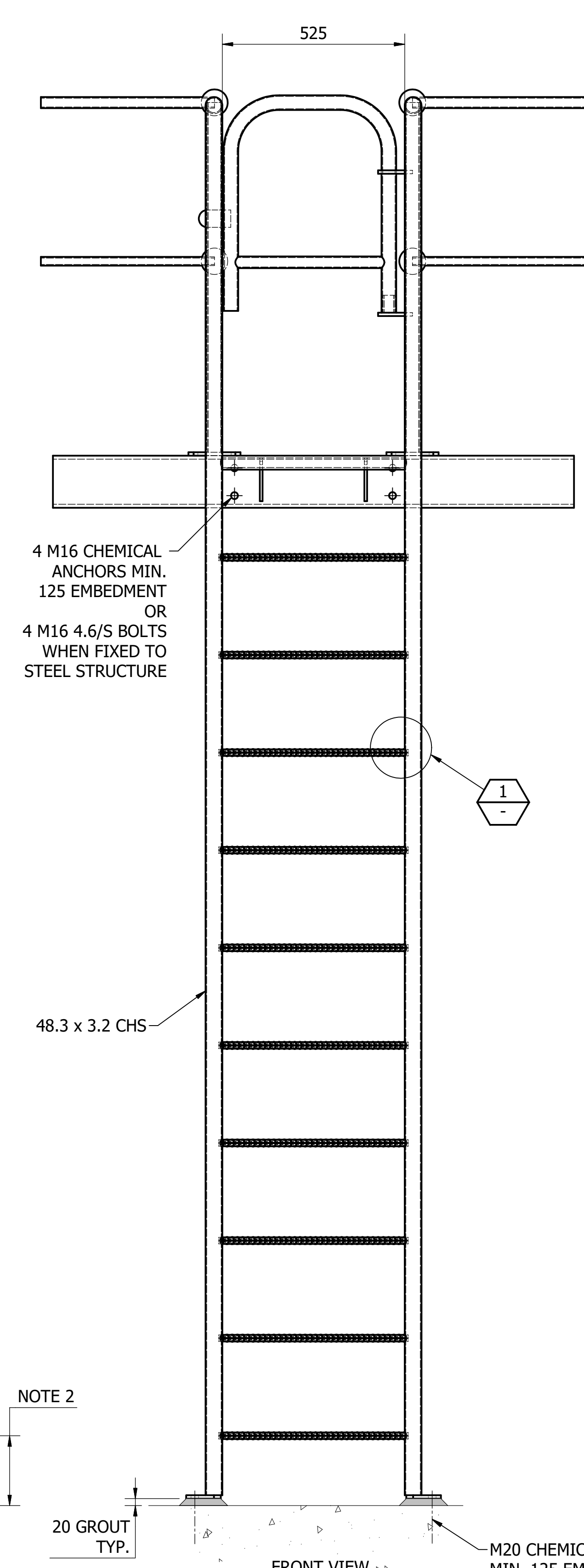

**INCLINED RUNG LADDER**  
**TYPICAL ASSEMBLY AND ARRANGEMENT**  
SCALE: 1 : 10

MATERIAL: CARBON STEEL  
COATING: HOT DIP GALVANISED  
FINISH COLOUR: N/A  
MASS: 65 kg @ 3 m LENGTH

**NOTES :**

- REFER TO SD-9100 FOR STEELWORK NOTES.
- RUNG SPACING BETWEEN 250 AND 300 ENSURING A CONSISTENT SPACING WHEN STEPPING ON & OFF THE RUNG LADDER. TREAD SPACING TOLERANCE SHALL BE ±5.
- THE LADDER ANGLE, NUMBER OF RUNGS AND OVERALL LADDER LENGTH ETC. SHALL BE NOMINATED BY THE DESIGNER SPECIFICALLY FOR THE PROJECT APPLICATION, BUT THE LADDER SHALL NOT EXCEED 3.0 m.
- SELF CLOSING GATE TO BE "WEBFORGE" MONOWILLS OR APPROVED EQUIVALENT. GATE TO OPEN AWAY FROM LADDER. SPECIFY SWING DIRECTION, CLEAR OPENING AND LOCKING REQUIREMENTS AS PER "WEBFORGE" CATALOGUE.
- QUANTITY AND MASS BASED ON A LADDER APPROX 3000 IN LENGTH.
- ALL WORKS SHALL COMPLY WITH AS 1657 AND ICON WATER SUPPLEMENT DOCUMENTS STD-SPE-G-008 AND 009.

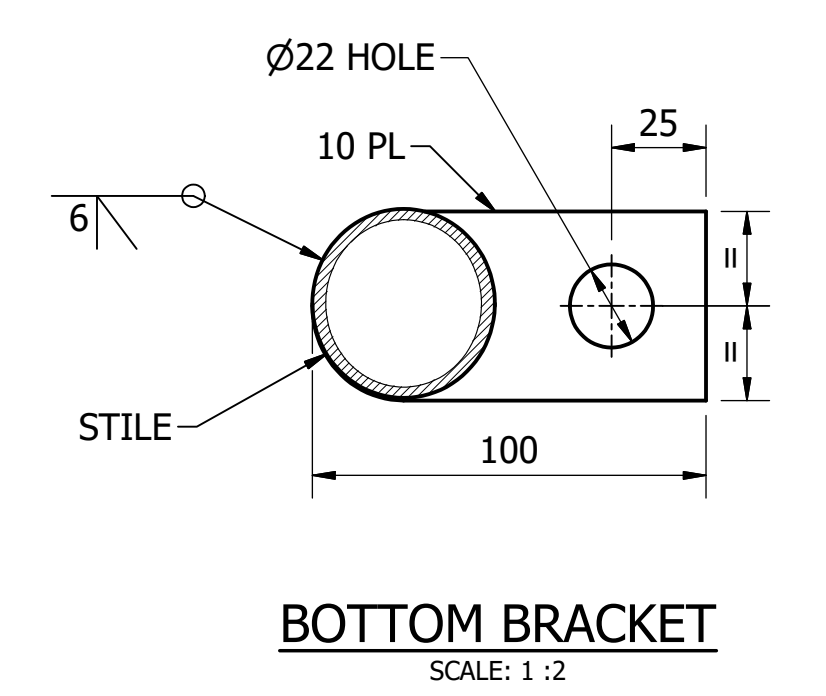
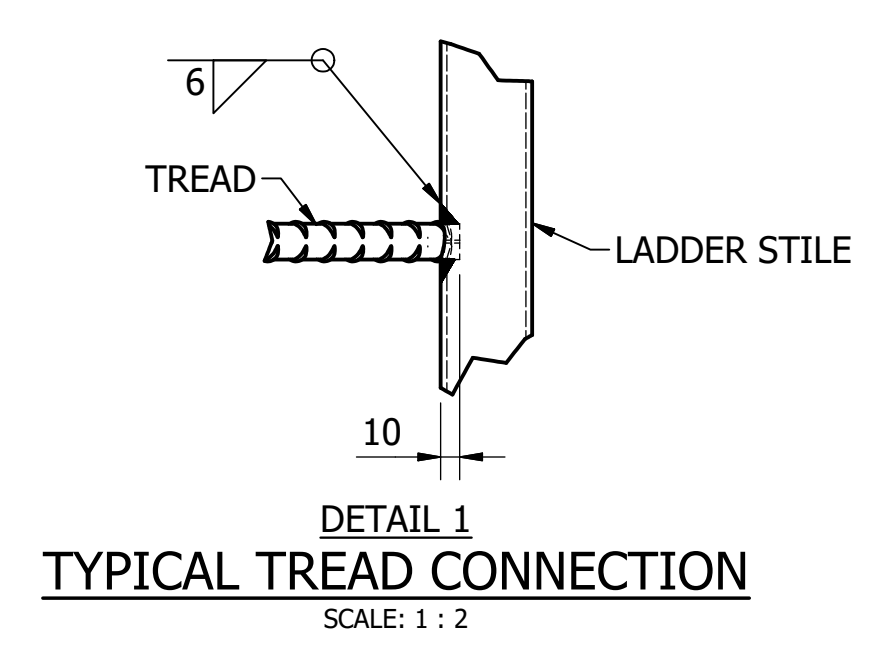

DAM	RES	SPS
BWS	WAT	STP
WTP	SEW	
WPS	REC	

ASSET AREA APPLICABILITY



STANDARD DRAWING  
HOT DIP GALVANISED STEEL LADDERS  
FIXED INCLINED RUNG LADDER WITH FIXED STANCHIONS  
ARRANGEMENT AND DETAILS

DRAWING STATUS	
Current	
SD-8107-D	
A1	ISSUE A

No.	ISSUE	DATE	DRAWN	CHECKED	AUTHORISED
A	INITIAL ISSUE	15/06/2018	S. Essery	K. Danenbergsons	D. Eager



**NOTES:**

- REFER TO SD-9100 SERIES FOR STEELWORK FABRICATION NOTES.
- FOR SEWERAGE APPLICATIONS, ONLY STAINLESS STEEL GRADE 316L OR HOT DIP GALVANISED CARBON STEEL SHALL BE USED FOR LADDERS, RUNGS, LANDINGS AND FASTENINGS ETC. OTHER CORROSION RESISTANT MATERIALS (e.g. POLY-COATED STEP-IRONS) SHALL NOT BE USED UNLESS APPROVAL IN WRITING IS RECEIVED FROM THE ICON WATER PRINCIPAL ENGINEER.
- ALL LADDERS, LANDINGS, HANDRAILS, STANCHIONS AND STEP-IRONS ETC. SHALL BE DESIGNED, FABRICATED AND INSTALLED IN ACCORDANCE WITH AS 1657, AS MODIFIED BY ICON WATER IN SPECIFICATION STD-SPE-G-008 AND 009.
- STEP-IRONS AND LADDER FIXINGS SHALL BE FIXED A MINIMUM DISTANCE OF 100 mm FROM A CONSTRUCTION JOINT.
- WHERE THE CLEAT IS POSITIONED IN THE TAPERED PART OF THE CHAMBER, THE LENGTH AND ANGLE OF CLEAT SHALL BE CALCULATED TO SUIT THE TAPER.
- WHERE DEPTH TO BENCHING IS > 6000 mm AN INTERMEDIATE LANDING SHALL BE INSTALLED. REFER TO SD-2203 FOR DETAILS.
- FOR SEWERS < DN600 LADDER TO BE LOCATED OVER OUTLET PIPE. FOR SEWERS ≥ DN600 LADDER TO BE LOCATED OVER BENCHING. WHERE LADDER IS LOCATED OVER BENCHING, MAINTENANCE HOLE TO BE OFFSET TO PROVIDE 150 mm BENCH WIDTH ON SIDE OPPOSITE LADDER.

**PLAN - TYPICAL Ø1050 MAINTENANCE HOLE WITH STAGGERED STEP-IRONS**  
SCALE: 1 : 25

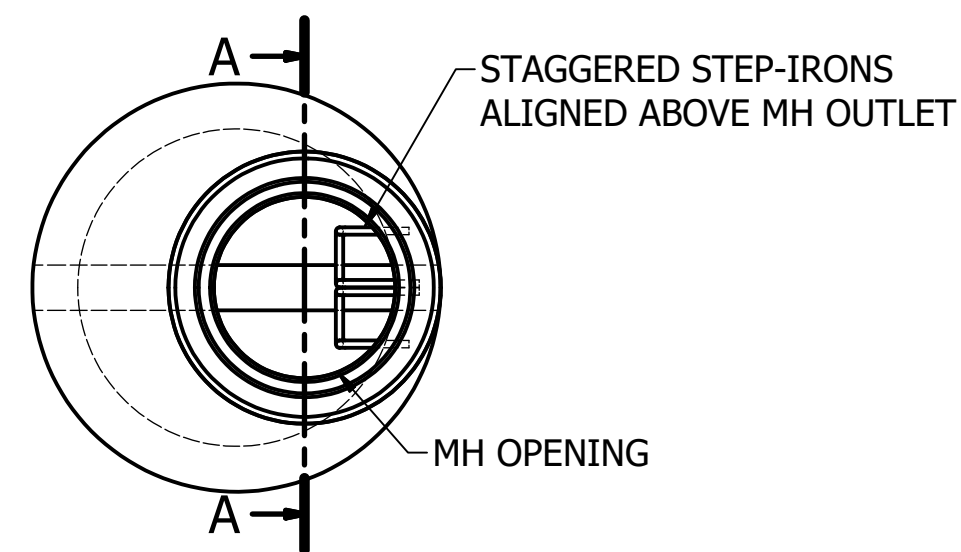

**DETAIL 1 STEP-IRON SET-OUT**

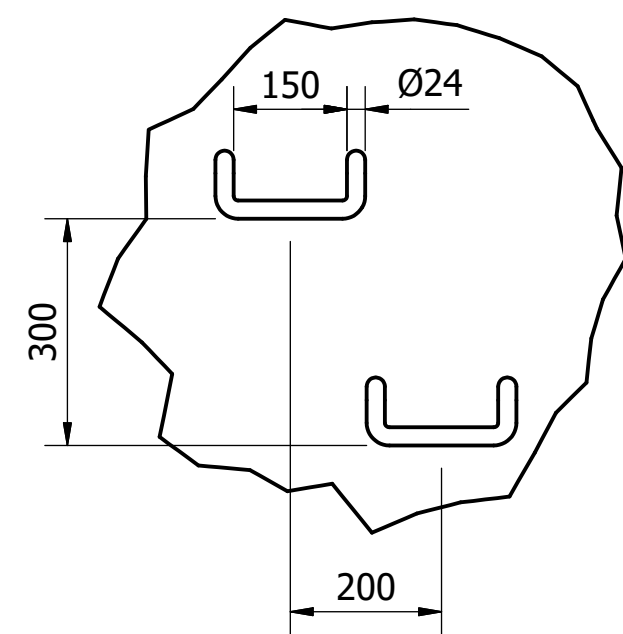

**PLAN - TYPICAL Ø1200 AND Ø1500 MAINTENANCE HOLE WITH FIXED VERTICAL LADDER AND INTERMEDIATE LANDING**  
SCALE: 1 : 25

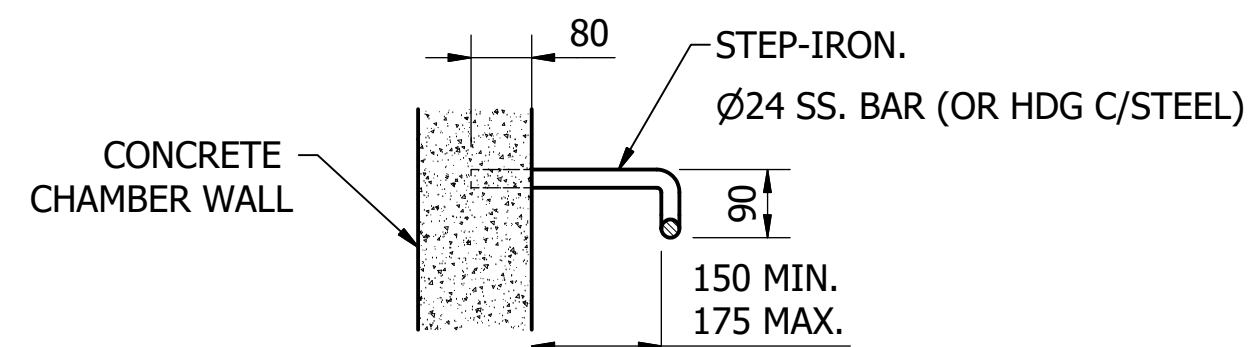
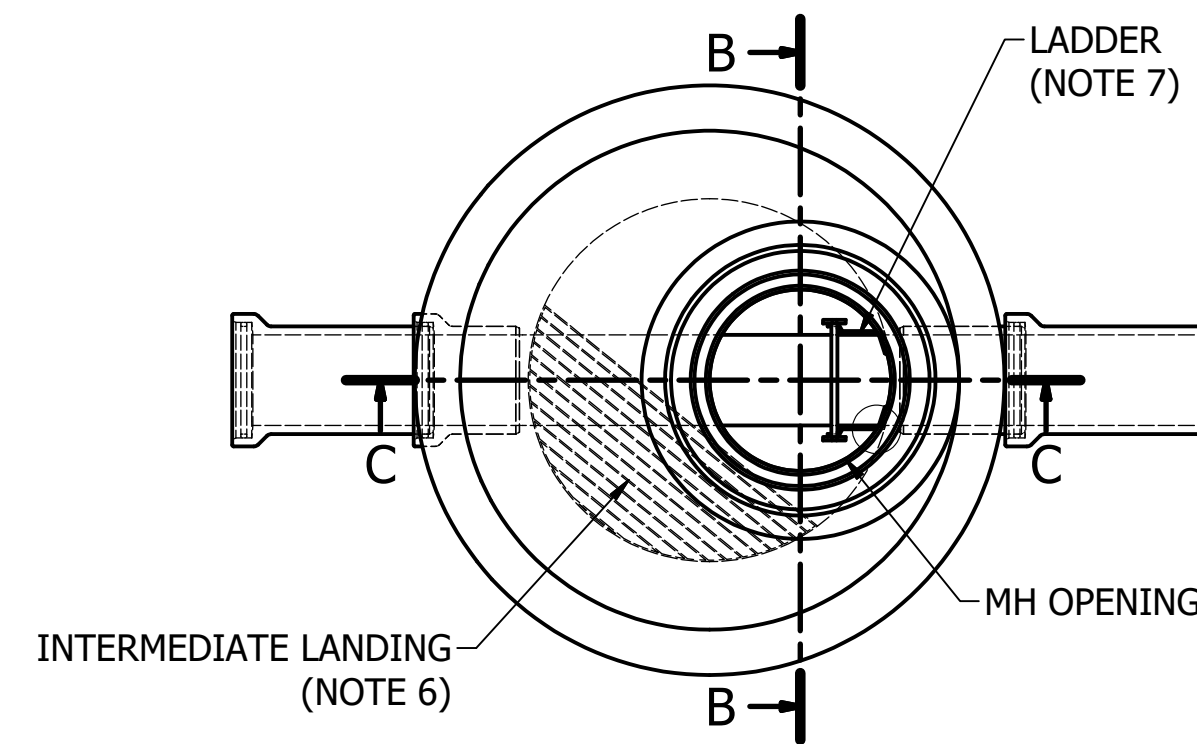

**DETAIL - STEP-IRON FIXING (NOTE 4)**  
SCALE: 1 : 10

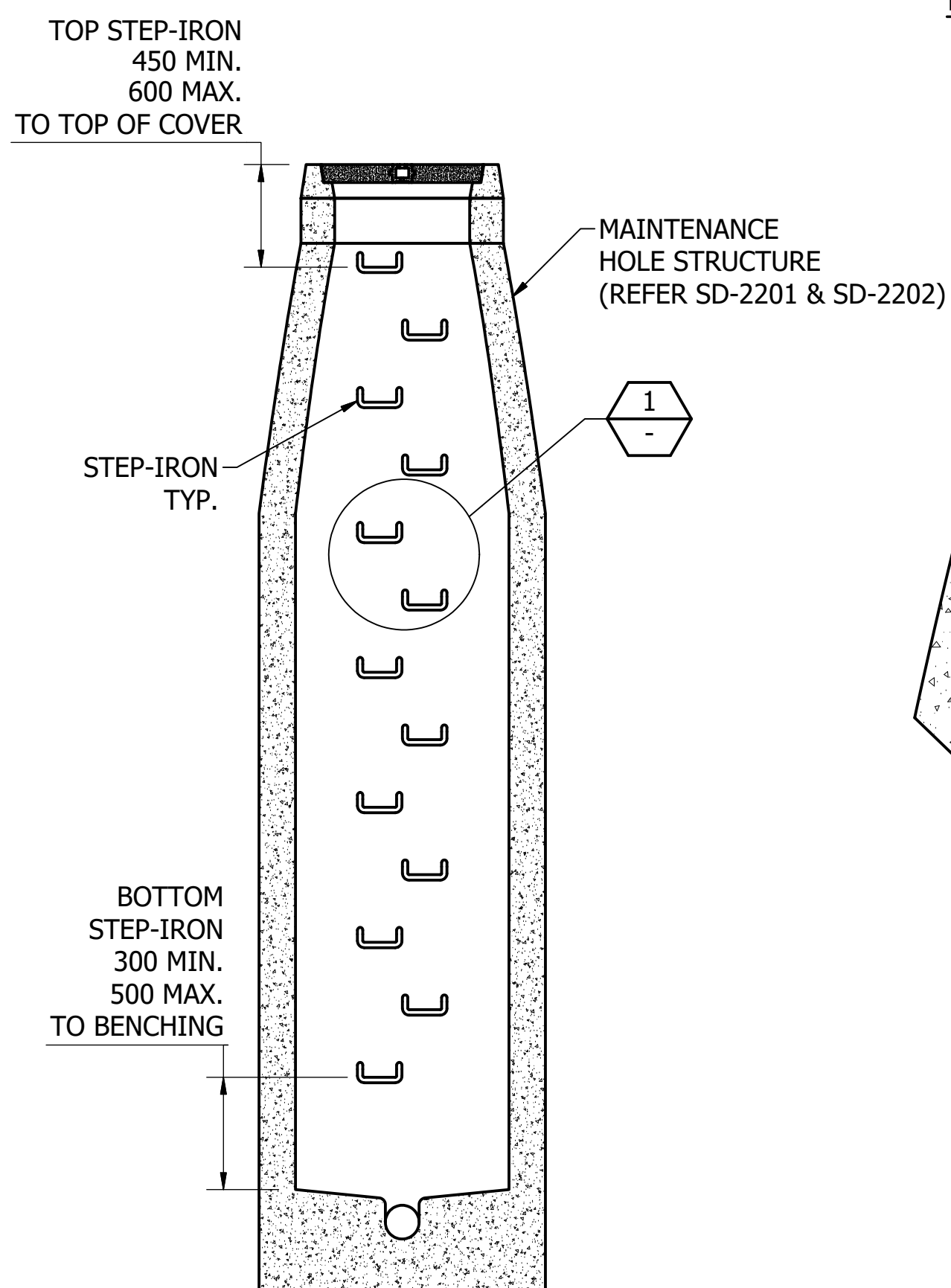

**TYPICAL FRONT VIEW**  
SCALE: 1 : 25

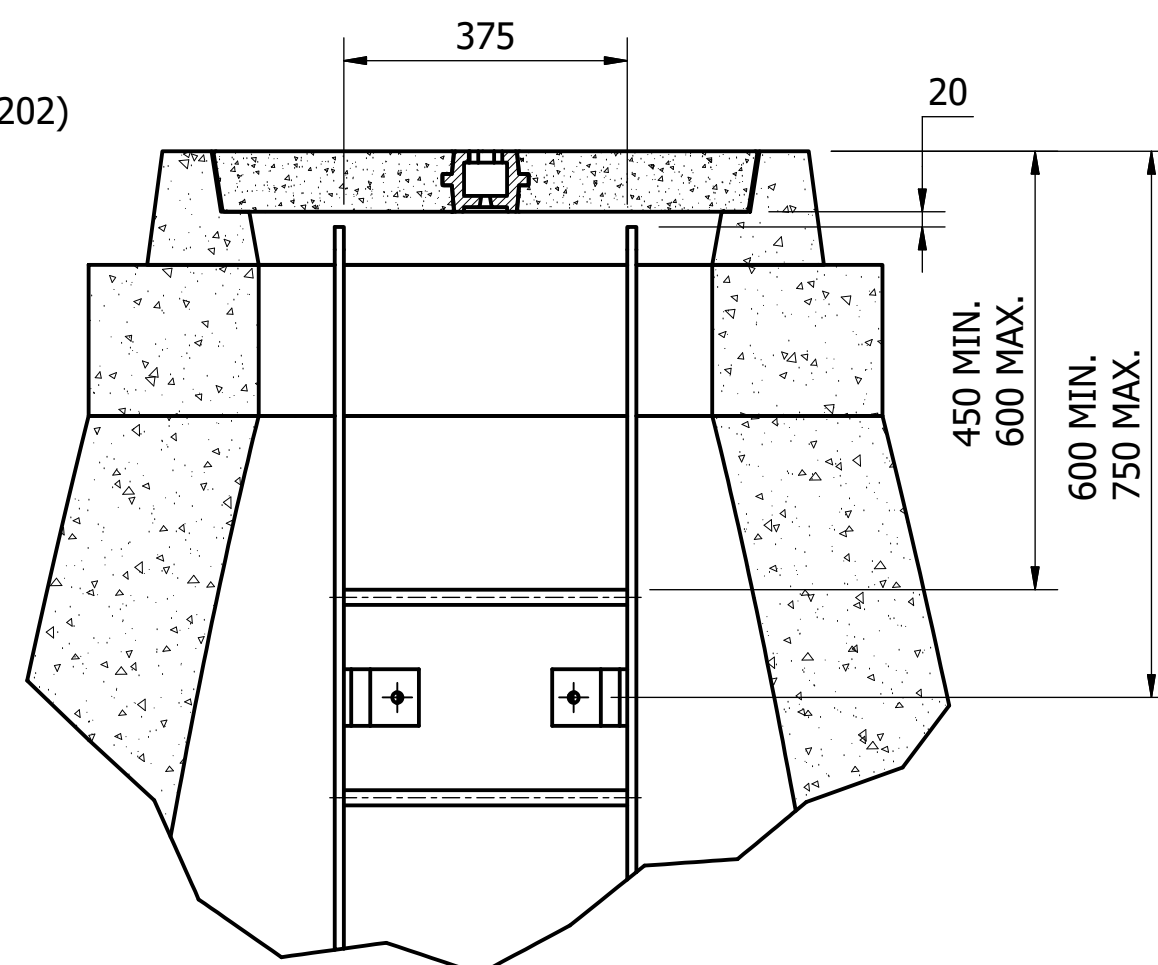

**LADDER SET-OUT TO TOP OF MH**  
SCALE: 1 : 10

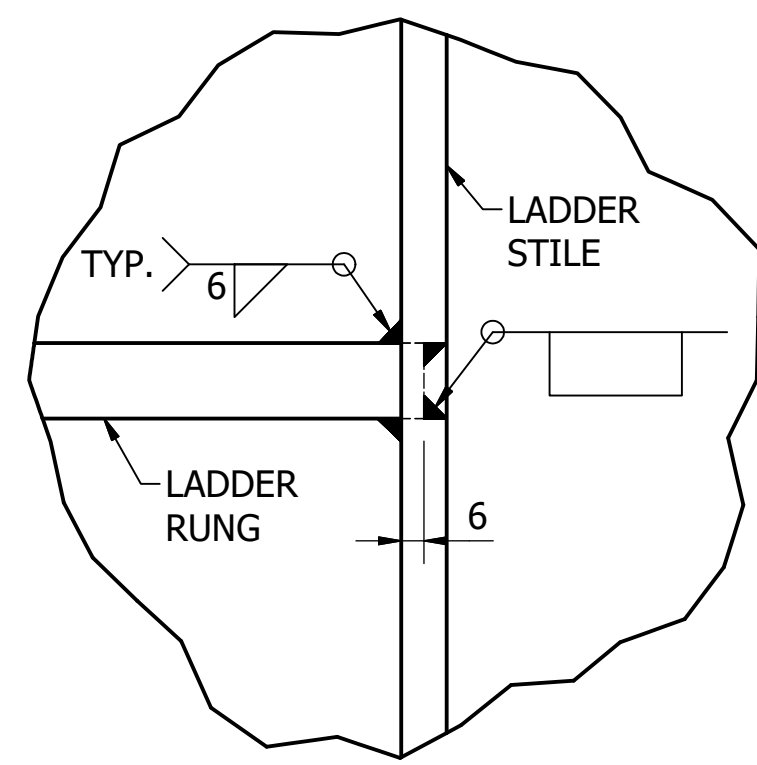

**TYPICAL TREAD CONNECTION**  
SCALE: 1 : 2

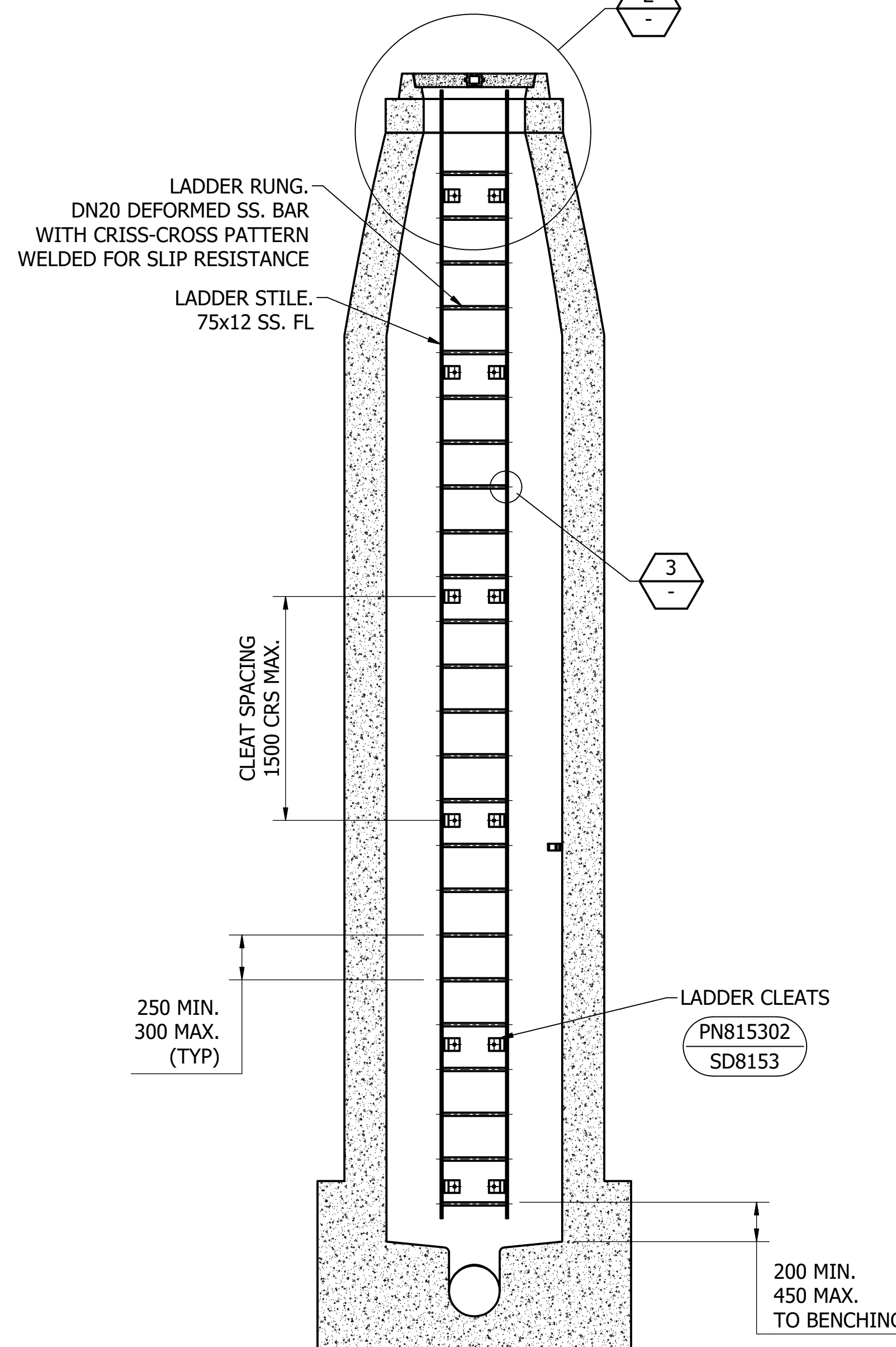

**TYPICAL FRONT VIEW (LANDING OMITTED FOR CLARITY)**  
SCALE: 1 : 25

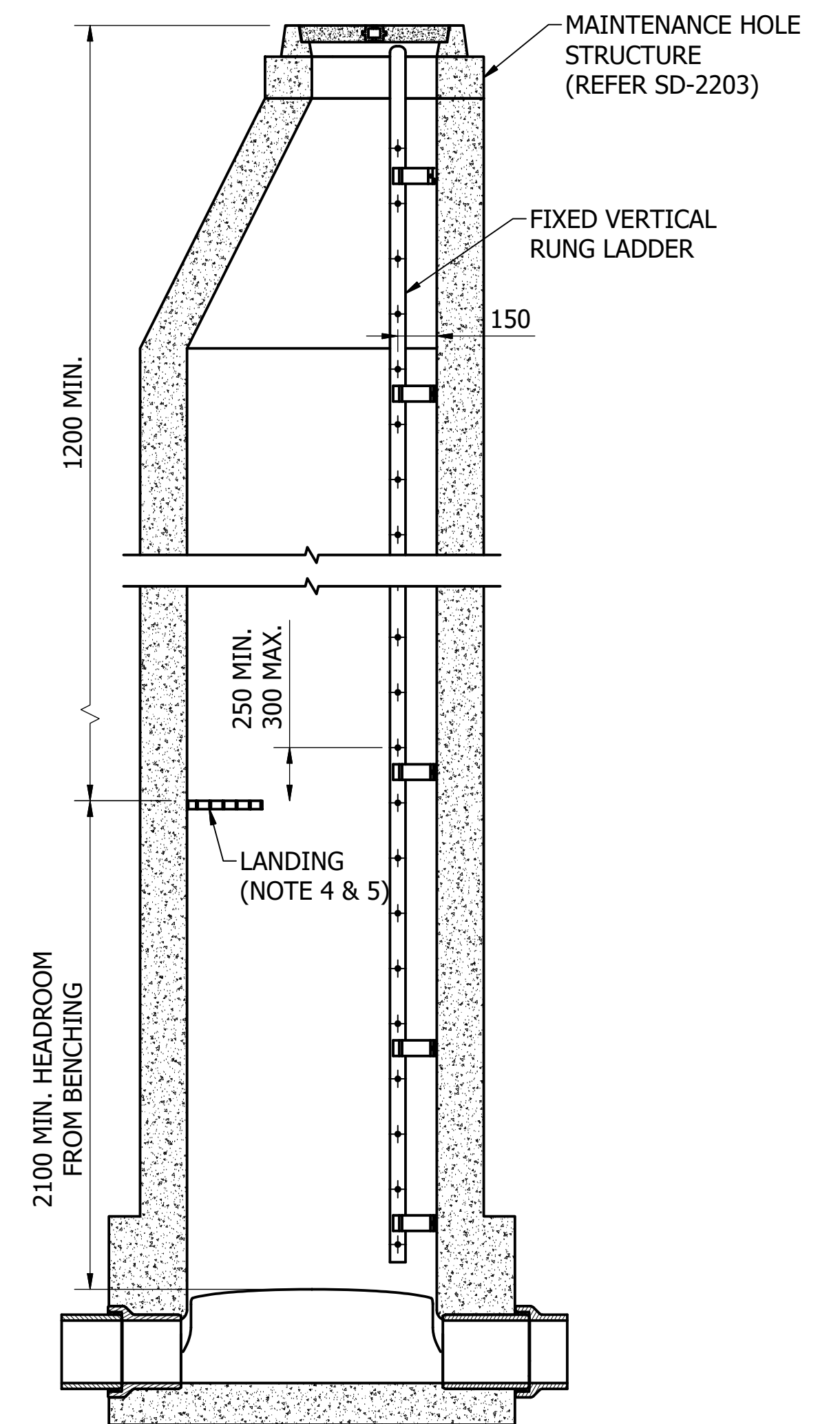

**TYPICAL SIDE VIEW (SHOWN WITH LANDING)**  
SCALE: 1 : 25

No.	ISSUE	DATE	DRAWN	CHECKED	AUTHORISED
A	INITIAL ISSUE	15/06/2018	M. Matusiak	K. Danenbergsons	D. Eager
B	STEP-IRON MATERIAL & NOTE 2 UPDATED. DRAWING NOW -D	19/06/2019	S. Essery	K. Danenbergsons	C. Patrick

DAM	RES	SPS	WTP	WAT	SEW	WPS	REC



**STANDARD DRAWING  
ACCESS LADDERS (FIXED VERTICAL)  
AND STAGGERED STEP-IRONS FOR MAINTENANCE HOLES  
DETAILS**

DRAWING STATUS	Current
<b>SD-8108-D</b>	ISSUE B
© Icon Water 2017	



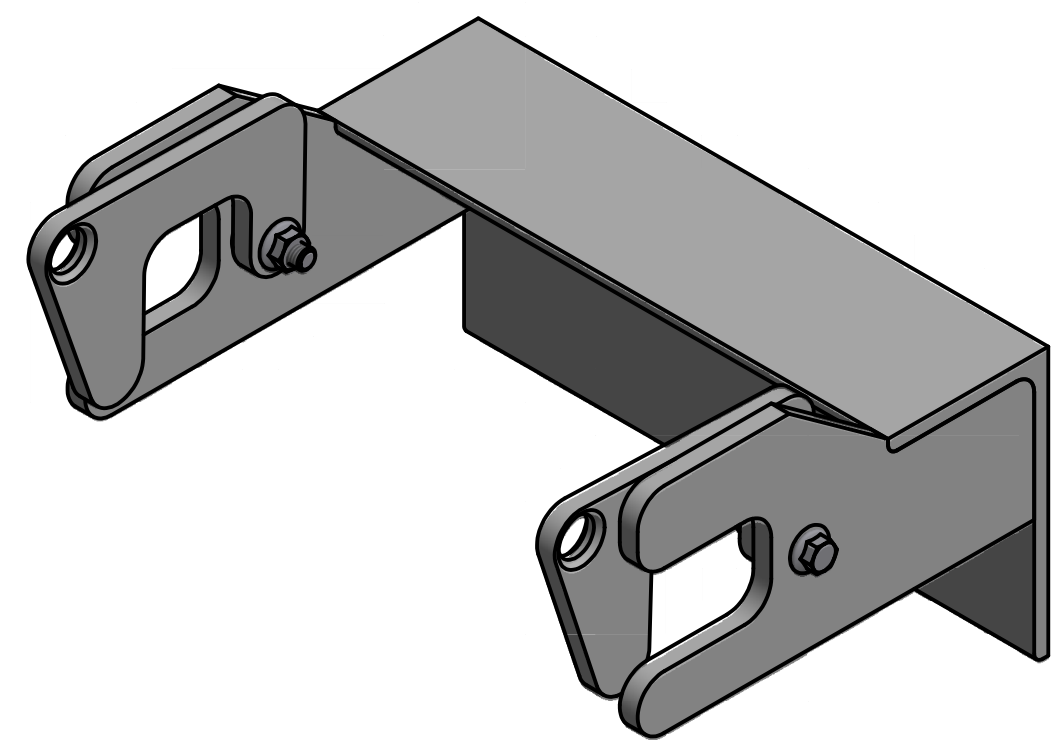

**ACCESS LADDER RETAINING PLATE ASSEMBLY ISOMETRIC VIEW**

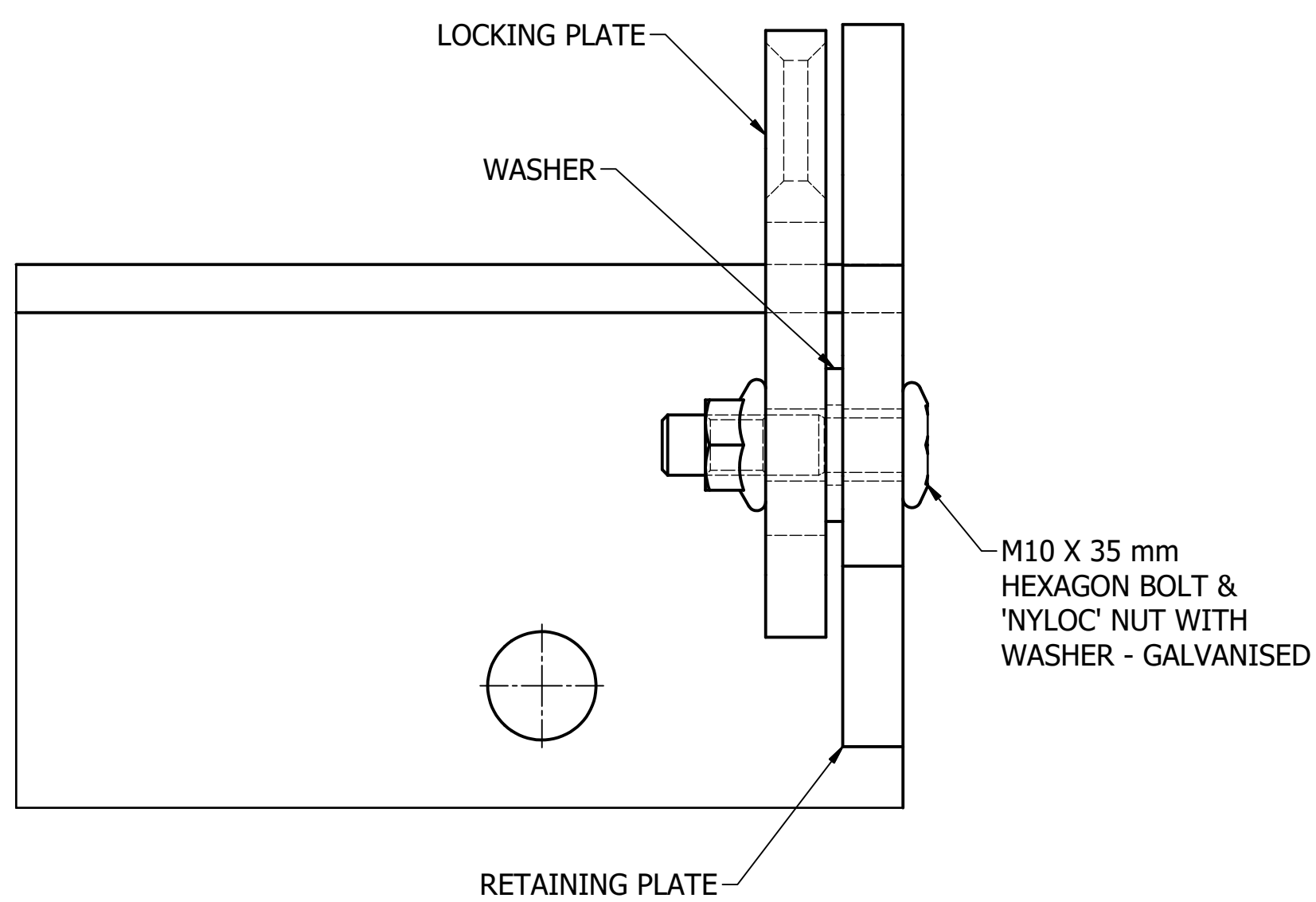

**RETAINING PLATE CONNECTION FIXING DETAIL**  
SCALE: 1 : 1

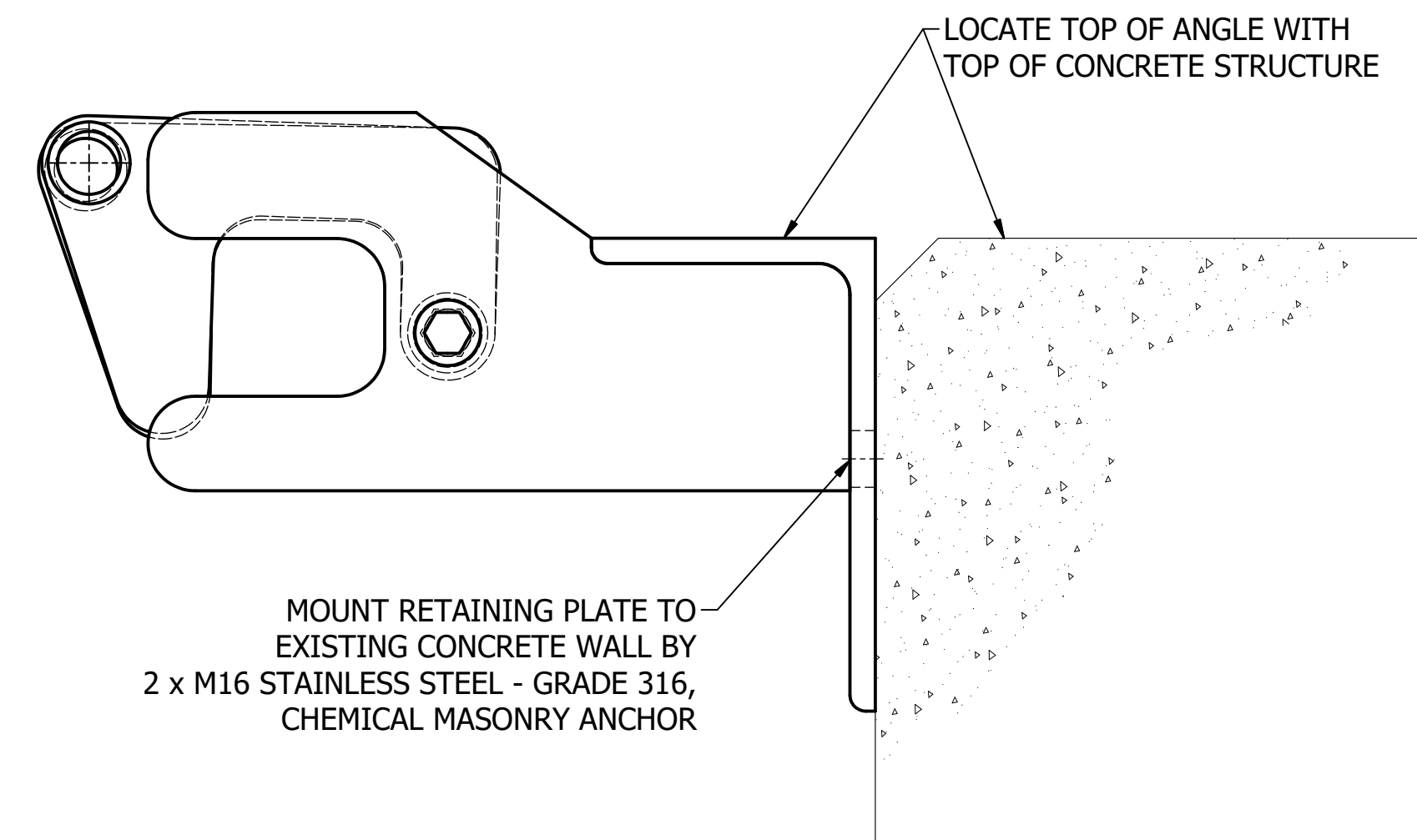

**INSTALLATION DETAIL**  
SCALE: 1 : 2

**ACCESS LADDER RETAINING PLATE ASSEMBLY**

**NOTES:**

1. ALL STEELWORK SHALL BE HOT DIP GALVANISED IN ACCORDANCE WITH AS/NZS 4680.
2. ALL WELDS SHALL BE 6 CONTINUOUS FILLET UNLESS NOTED OTHERWISE. ALL WELDS SHALL BE IN ACCORDANCE WITH AS/NZS 1554.
3. ALL STEELWORK SHALL BE FREE OF DIRT, BURRS, SHARP EDGES OR OTHER SHARP PROJECTIONS.
4. INSULATING MATERIAL TO BE INSTALLED BETWEEN STAINLESS STEEL AND OTHER METALLIC COMPONENTS.
5. MINIMUM 20 THICKNESS NON-SHRINK GROUT SHALL BE PROVIDED FOR ALL SUPPORT BASE PLATES.

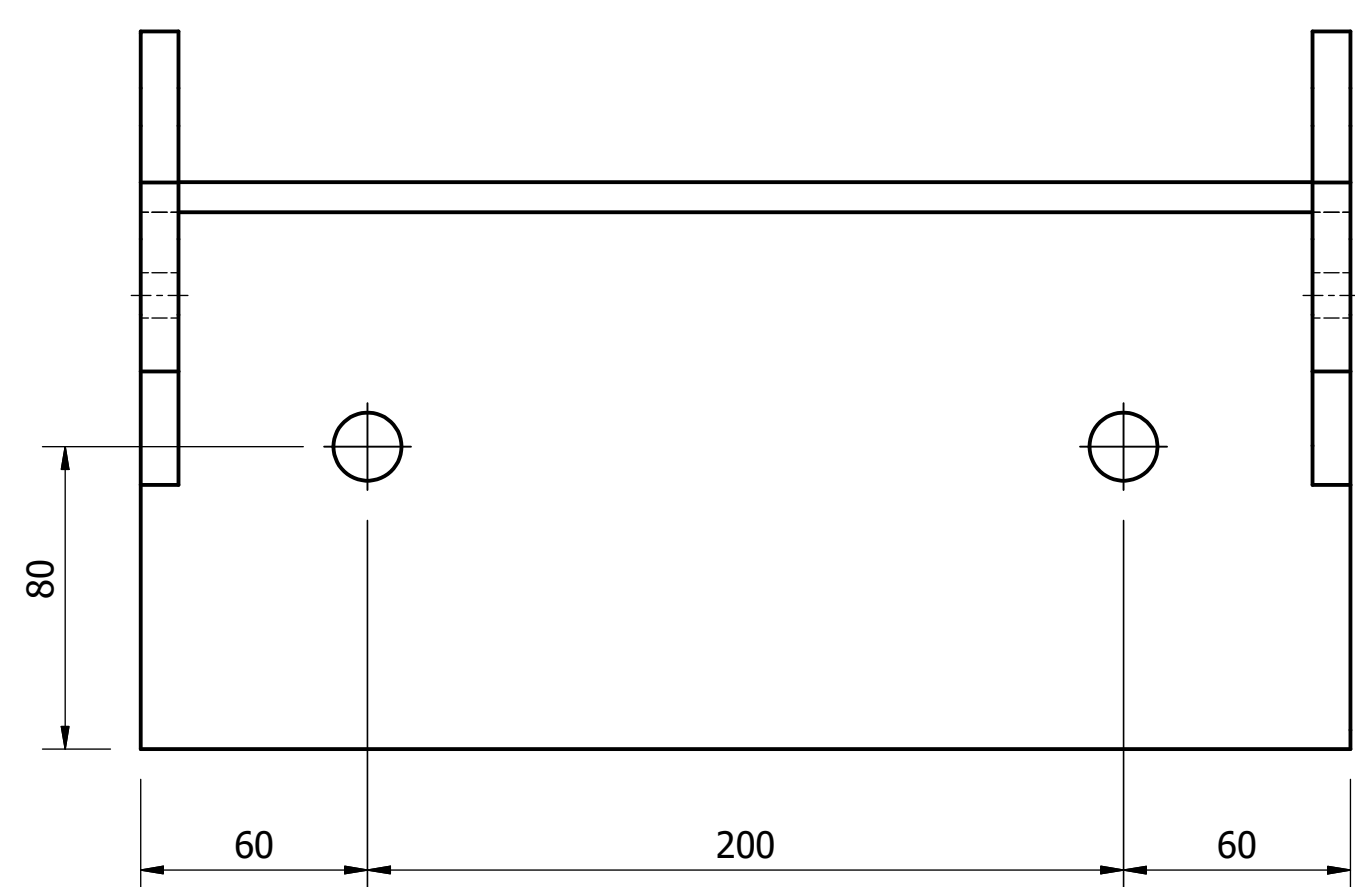

**FRONT VIEW**

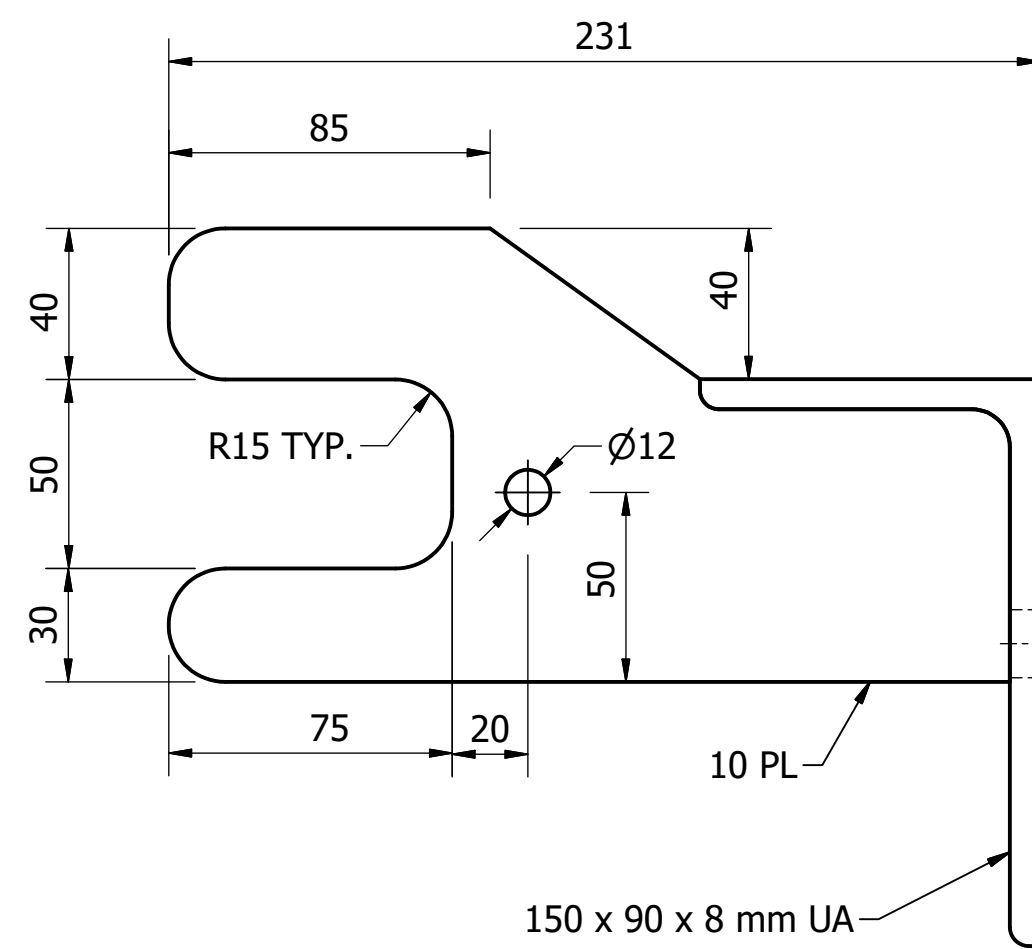

**SIDE VIEW**

**RETAINING PLATE**  
SCALE: 1 : 2

MATERIAL: CARBON STEEL  
COATING: HOT DIP GALVANISED  
FINISH COLOUR: N/A  
MASS: 10 kg APPROX.

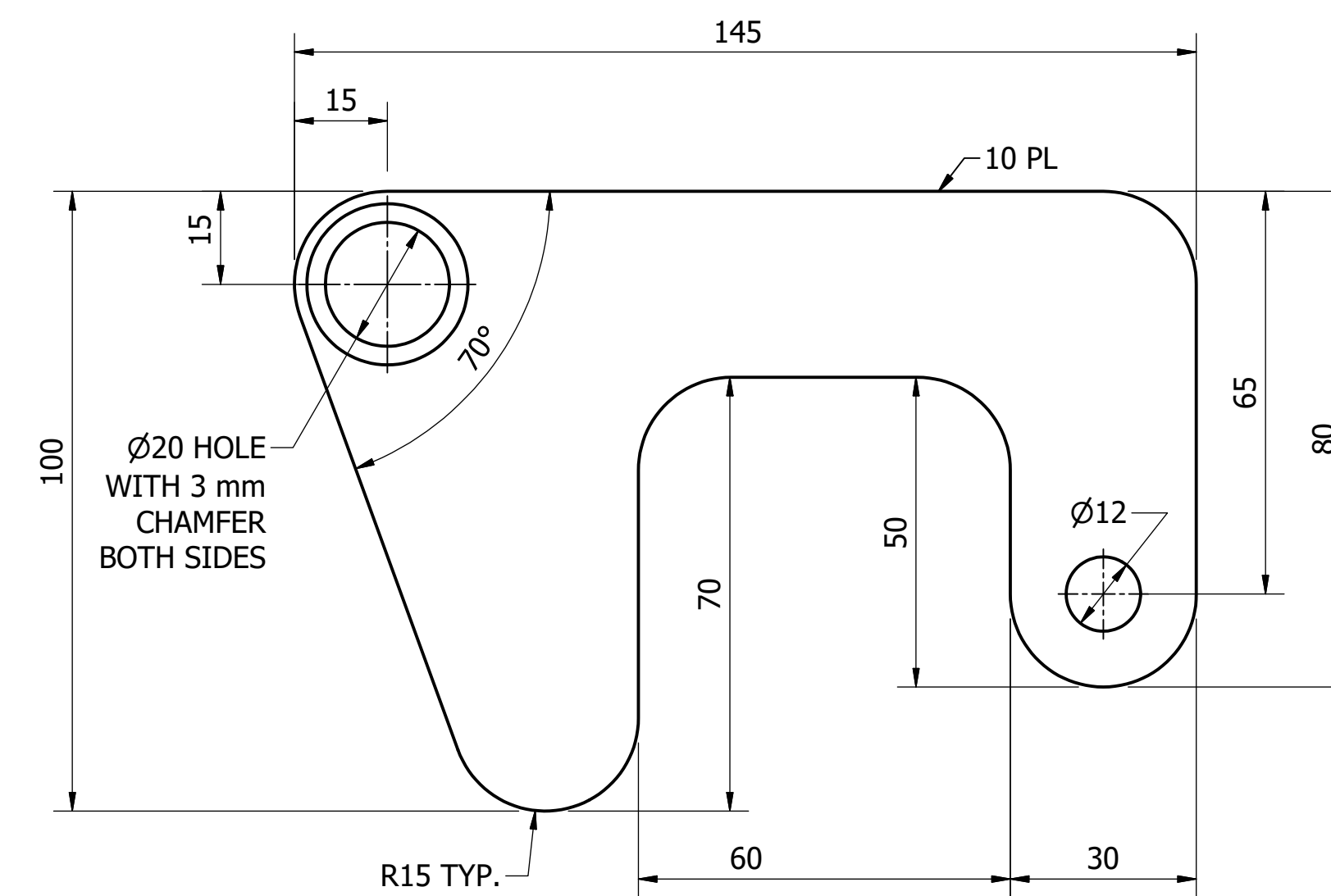

**SIDE VIEW**

**LOCKING PLATE**  
SCALE: 1 : 1

MATERIAL: CARBON STEEL  
COATING: HOT DIP GALVANISED  
FINISH COLOUR: N/A  
MASS: 5 kg APPROX.

ITEM	AMDT.
PN815101	

No.	ISSUE	DATE	DRAWN	CHECKED	AUTHORISED
A	INITIAL ISSUE	15/06/2018	K. Patel	K. Danenbergsons	D. Eager

DAM	RES	SPS
BWS	WAT	STP
WTP	SEW	
WPS	REC	



STANDARD DRAWING  
LADDER LOCKS FOR PORTABLE LADDERS  
RETAINING PLATE - CONCRETE STRUCTURE MOUNTED  
ASSEMBLY AND DETAILS

DRAWING STATUS	
Current	
SD-8151-D	
A1	ISSUE A

© Icon Water 2017



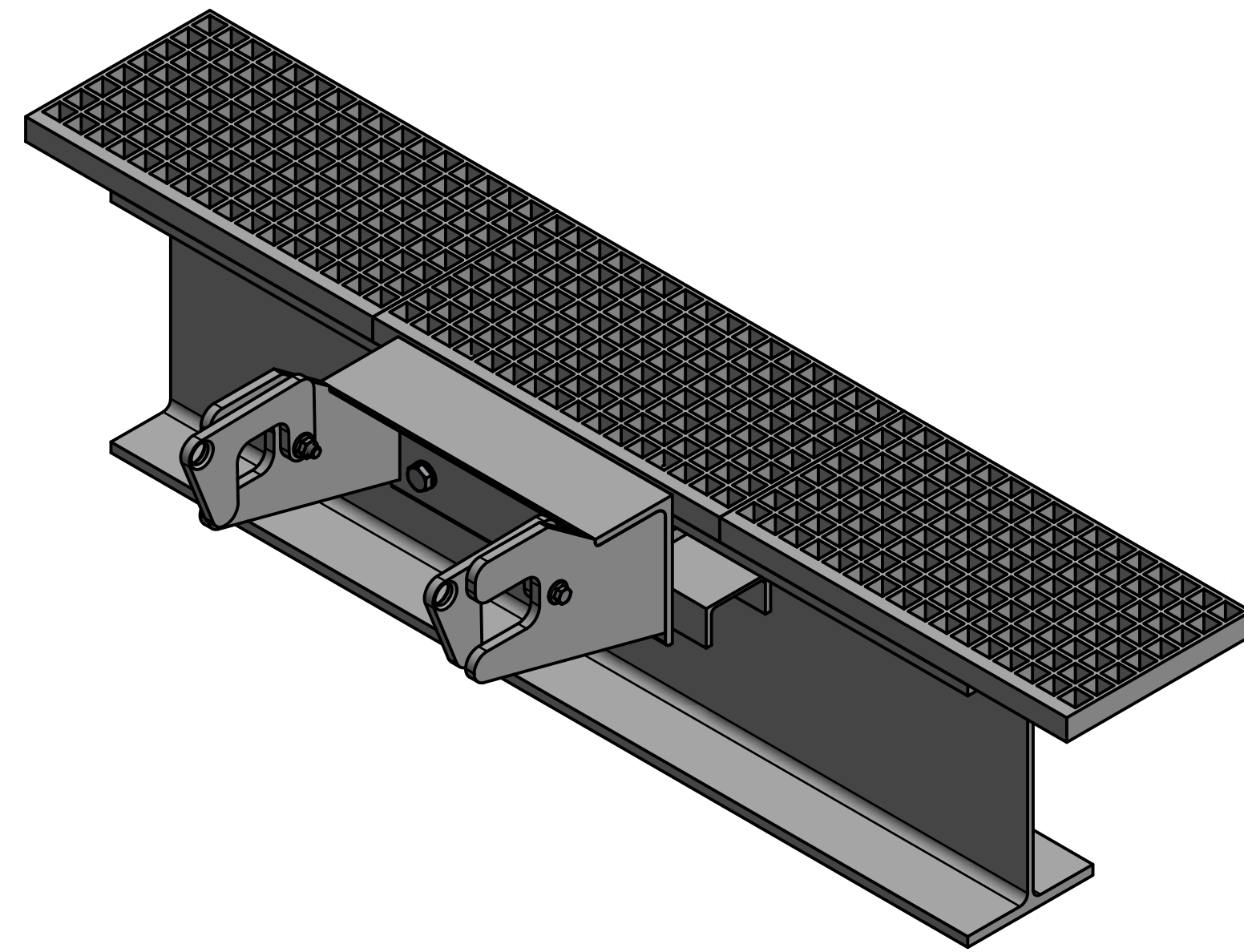

**ACCESS LADDER RETAINING PLATE ASSEMBLY ISOMETRIC VIEW**  
SCALE: 1 : 5

**NOTES:**

1. ALL STEELWORK SHALL BE HOT DIP GALVANISED IN ACCORDANCE WITH AS/NZS 4680.
2. ALL WELDS SHALL BE 6 mm CONTINUOUS FILLET UNLESS NOTED OTHERWISE. ALL WELDS SHALL BE IN ACCORDANCE WITH AS/NZS 1554.
3. ALL STEELWORK SHALL BE FREE OF DIRT, BURRS, SHARP EDGES OR OTHER SHARP PROJECTIONS.
4. INSULATING MATERIAL TO BE INSTALLED BETWEEN STAINLESS STEEL AND OTHER METALLIC COMPONENTS.
5. MATERIAL TO BE STRUCTURAL STEEL, WELDED FABRICATION, HOT DIP GALVANISED.
6. GRATING TO BE CLEAR OF BOLT HEADS.

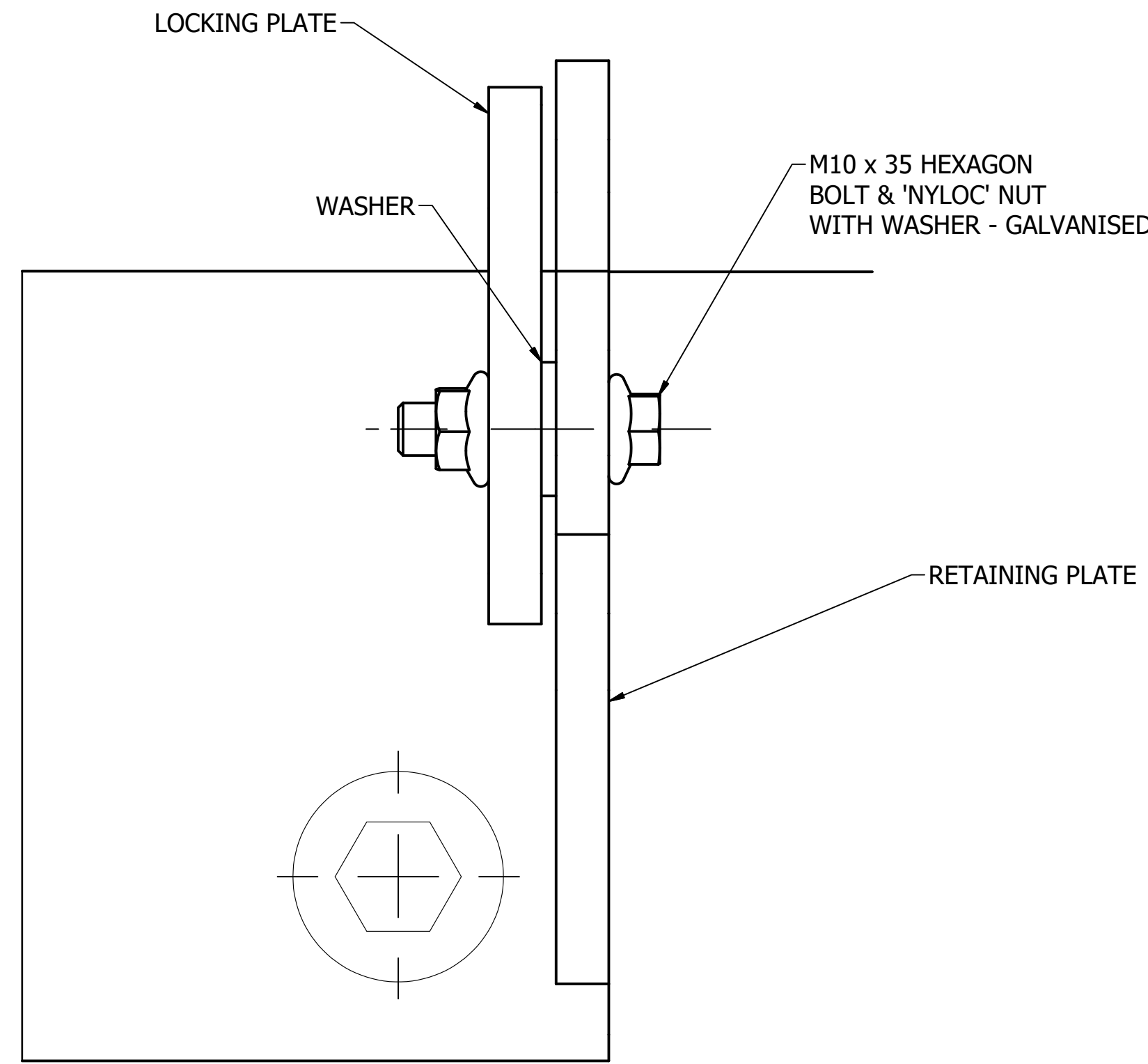

**RETAINING PLATE CONNECTION FIXING DETAIL**  
SCALE: 1 : 1

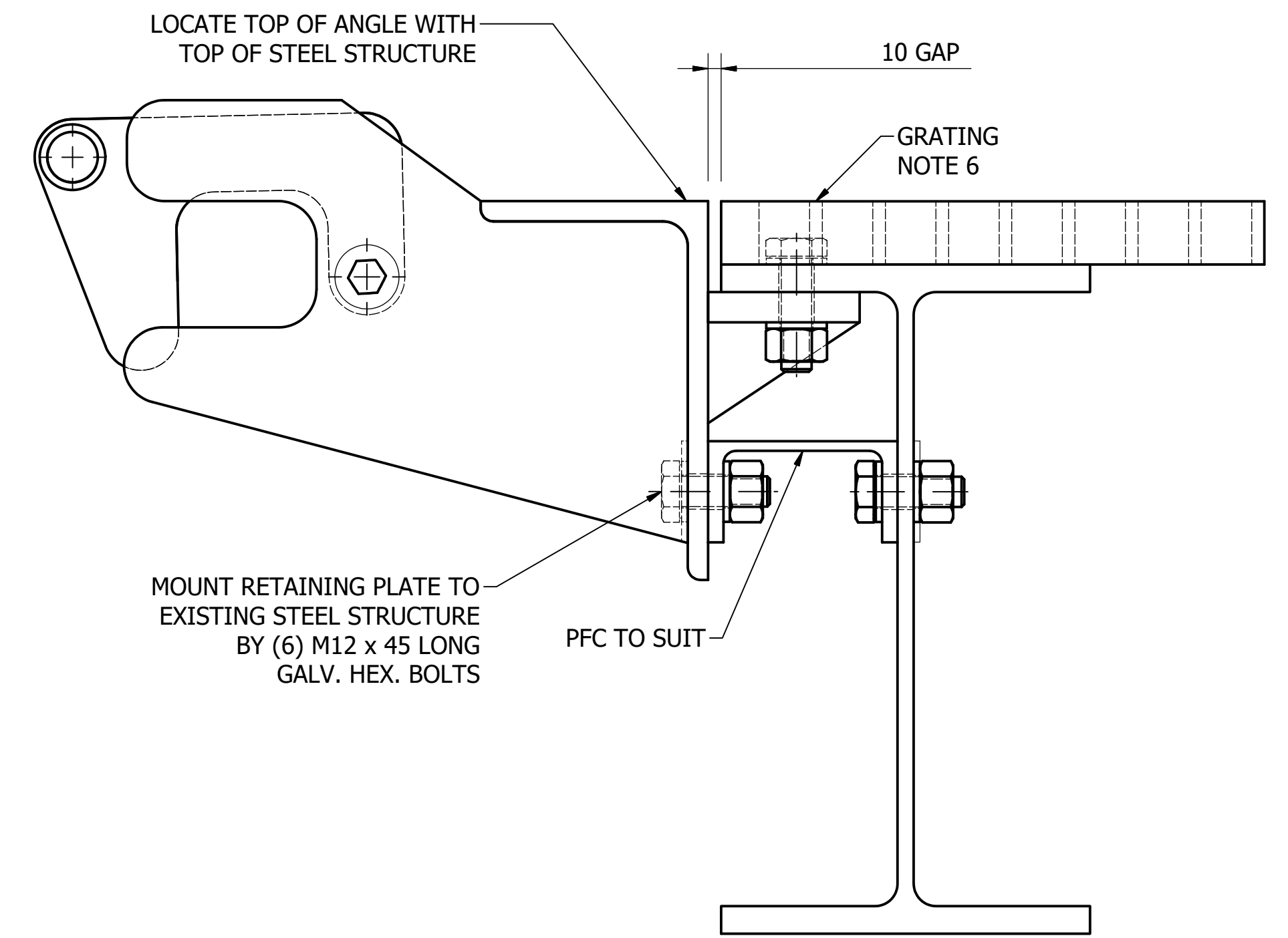

**INSTALLATION DETAIL**  
SCALE: 1 : 2

**ACCESS LADDER RETAINING PLATE ASSEMBLY**

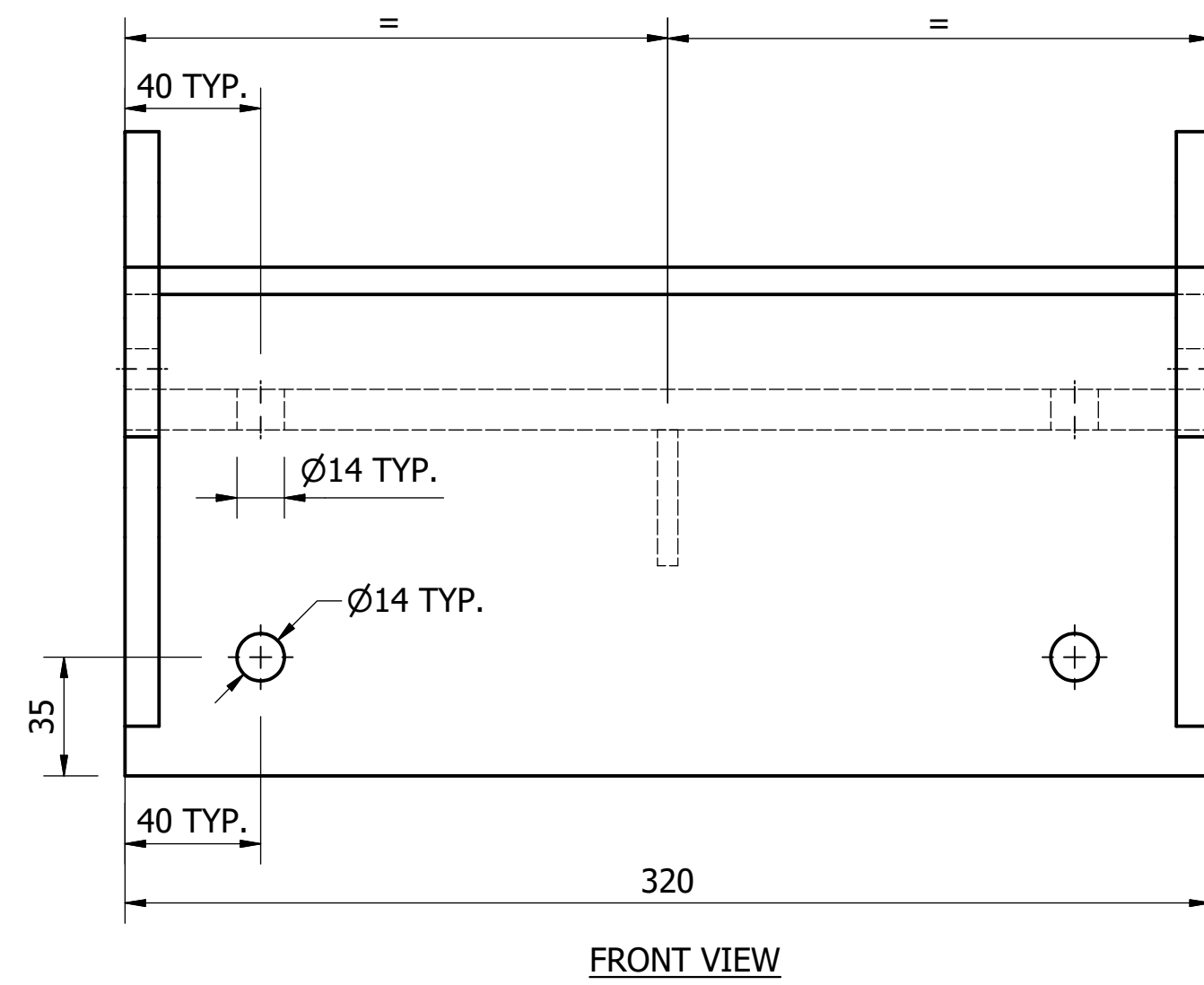

**ACCESS LADDER RETAINING PLATE**  
SCALE: 1 : 2

MATERIAL: CARBON STEEL  
COATING: HOT DIP GALVANISED  
FINISH COLOUR: N/A  
MASS: 10 kg APPROX.

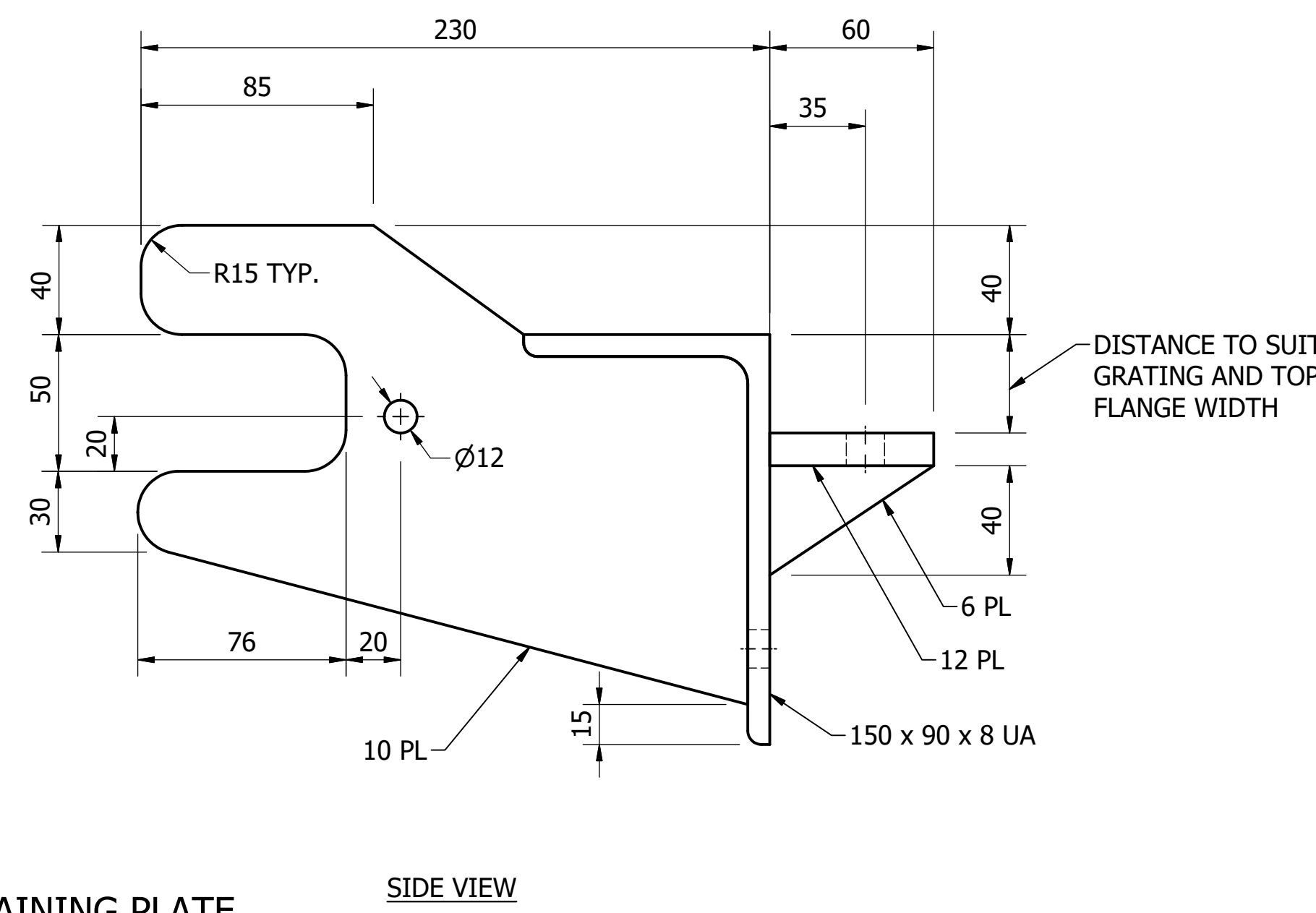

**SIDE VIEW**

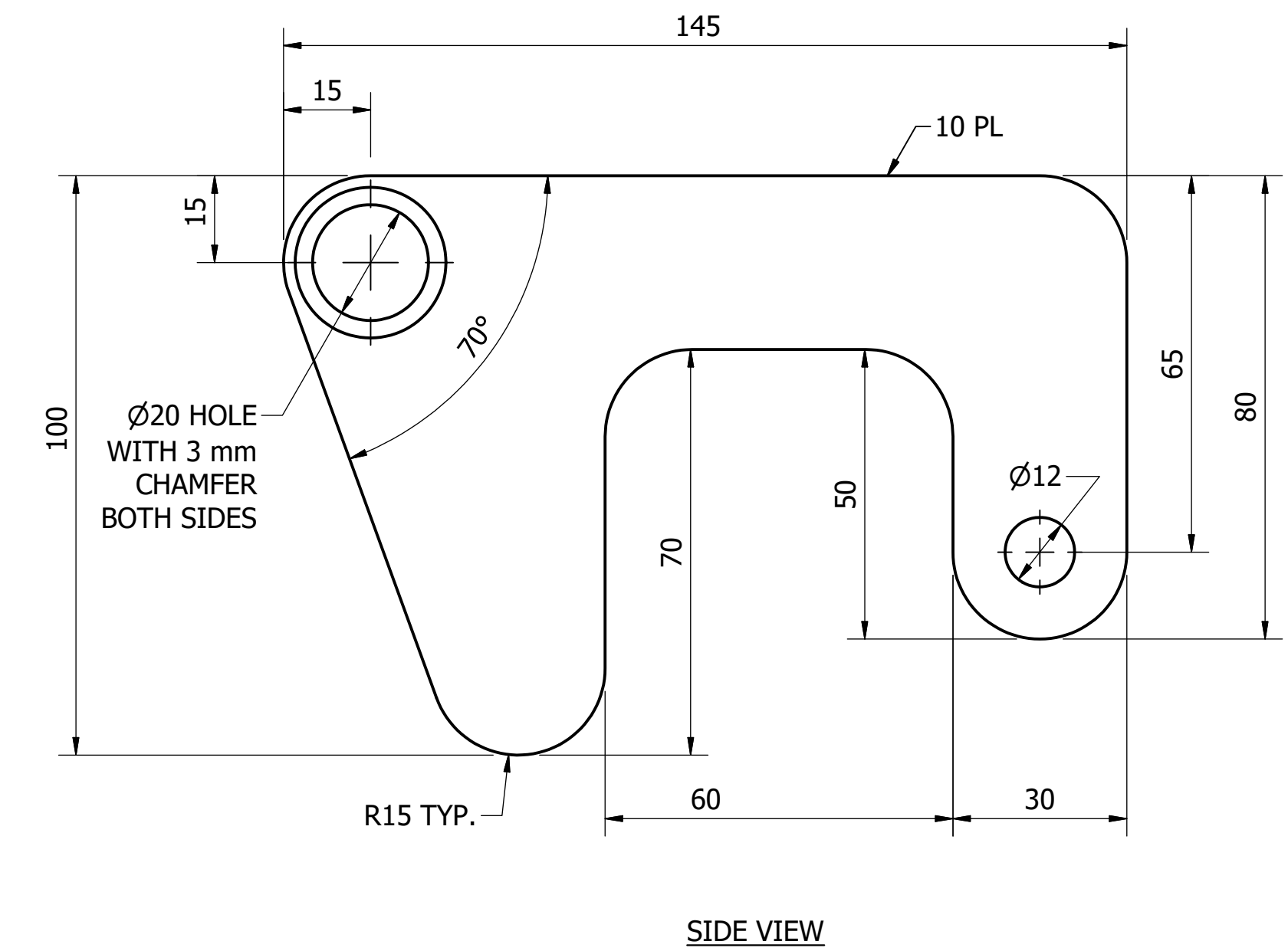

**SIDE VIEW**

**LOCKING PLATE**  
SCALE: 1 : 1

MATERIAL: CARBON STEEL  
COATING: HOT DIP GALVANISED  
FINISH COLOUR: N/A  
MASS: 5 kg APPROX.

ITEM	AMDT.
PN815201	

DAM	RES	SPS
BWS	WAT	STP
WTP	SEW	
WPS	REC	



STANDARD DRAWING  
LADDER LOCKS FOR PORTABLE LADDERS  
RETAINING PLATE - STEEL STRUCTURE MOUNTED  
ASSEMBLY AND DETAILS

DRAWING STATUS	Current
SD-8152-D	ISSUE A
A1	© Icon Water 2017

No.	ISSUE	DATE	DRAWN	CHECKED	AUTHORISED
A	INITIAL ISSUE	15/06/2018	K. Patel	K. Danenbergson	D. Eager



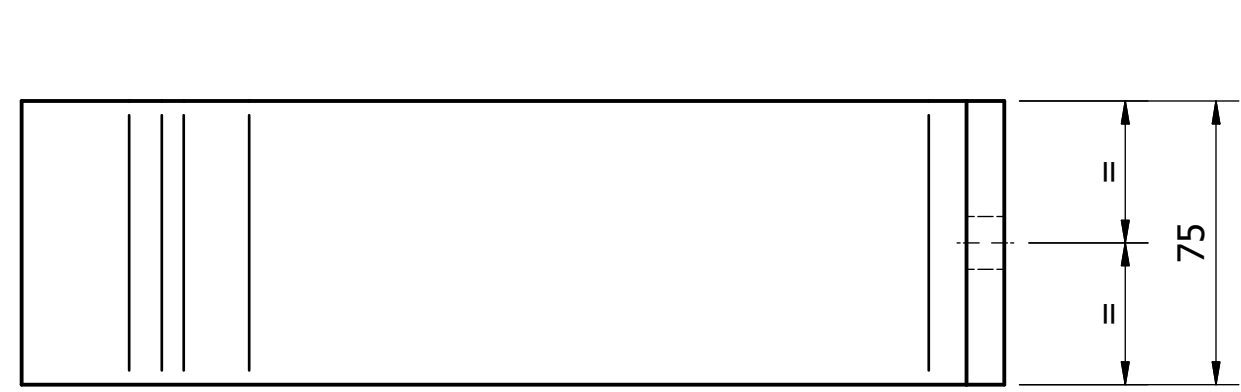
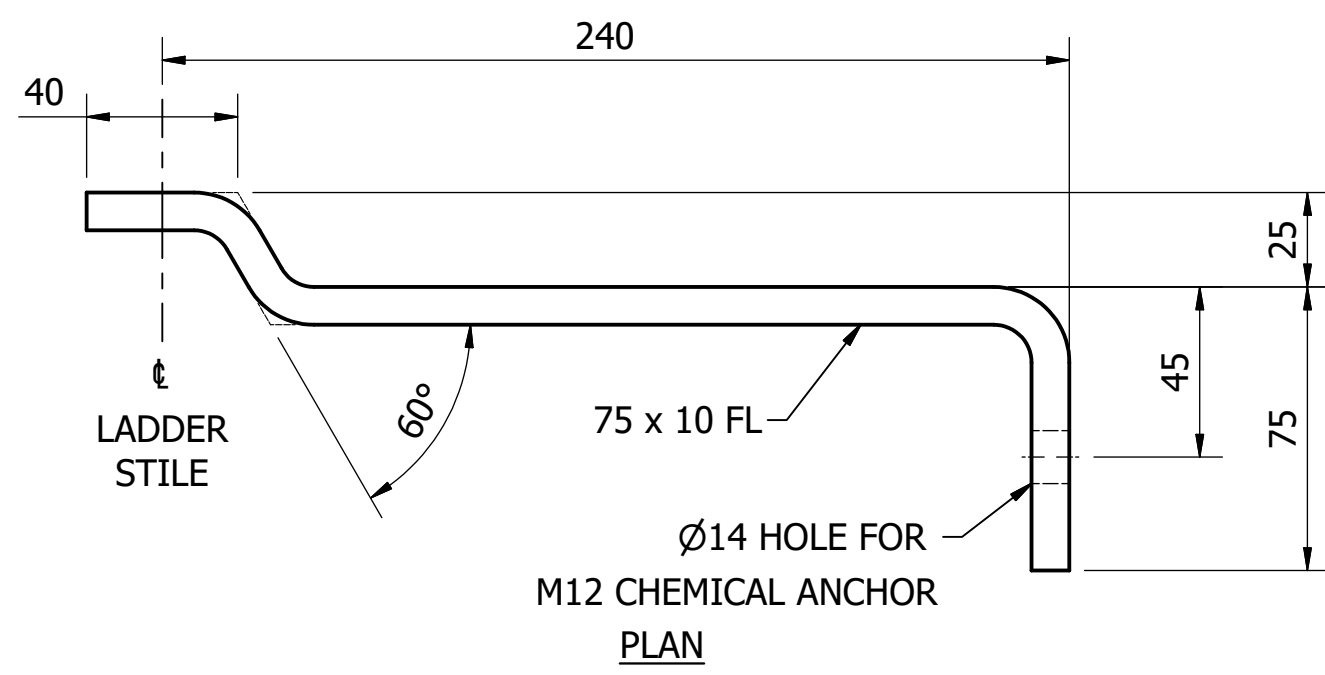

SIDE VIEW

**WALL BRACKET - VERTICAL RUNG LADDER**

SCALE: 1 : 2

MATERIAL: CARBON STEEL  
 COATING: HOT DIP GALVANISED (AS PART OF LADDER ASSY.)  
 FINISH COLOUR: N/A  
 MASS: 2 kg

ITEM	AMDT.
PN815301	

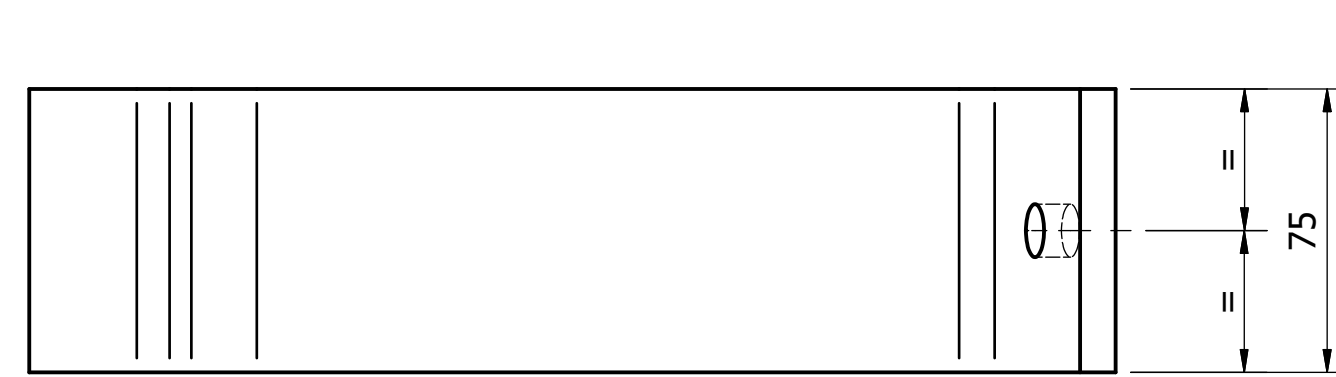
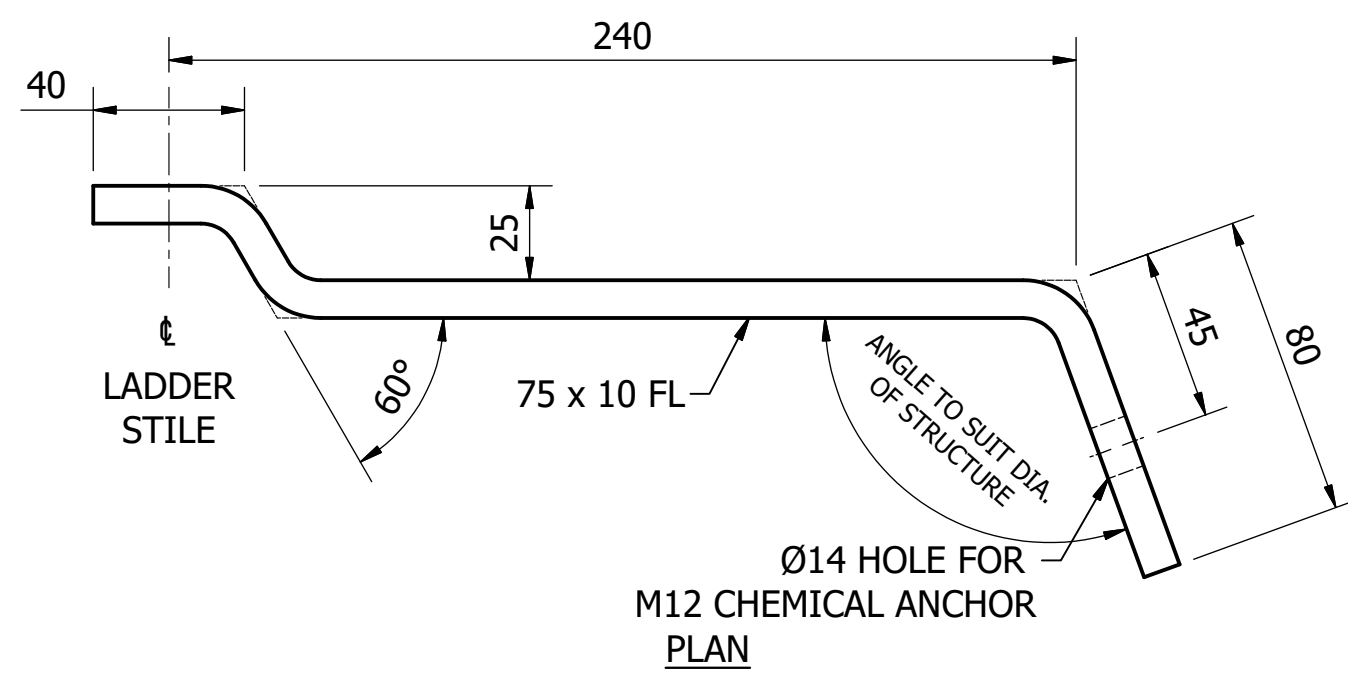

SIDE VIEW

**WALL BRACKET - VERTICAL RUNG LADDER  
 (INSTALLED IN ROUND STRUCTURE)**

SCALE: 1 : 2

MATERIAL: CARBON STEEL / STAINLESS STEEL G316L FOR USE IN MH'S  
 COATING: HOT DIP GALVANISED (AS PART OF LADDER ASSY.)  
 FINISH COLOUR: N/A  
 MASS: 2 kg

ITEM	AMDT.
PN815302	

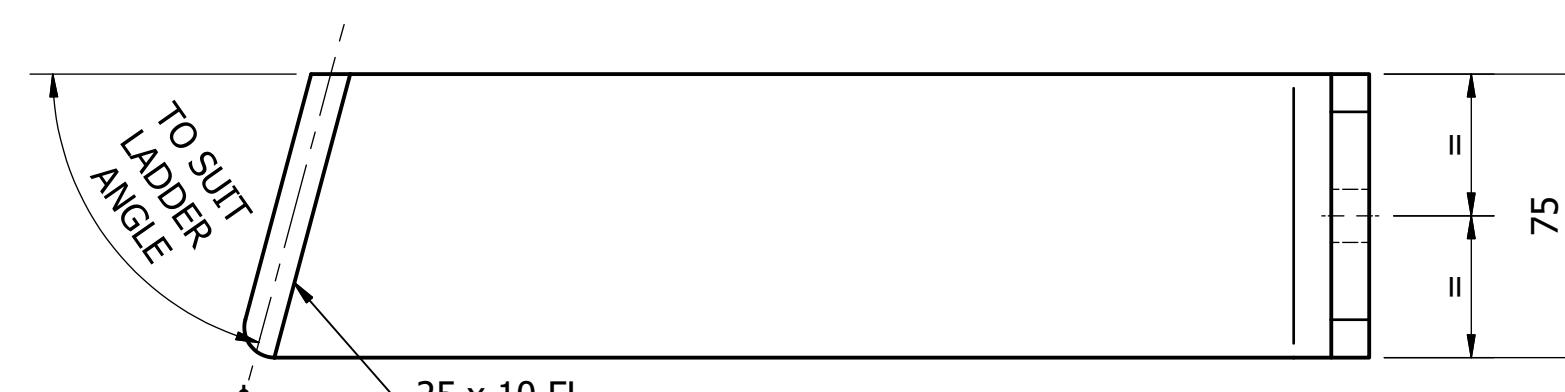
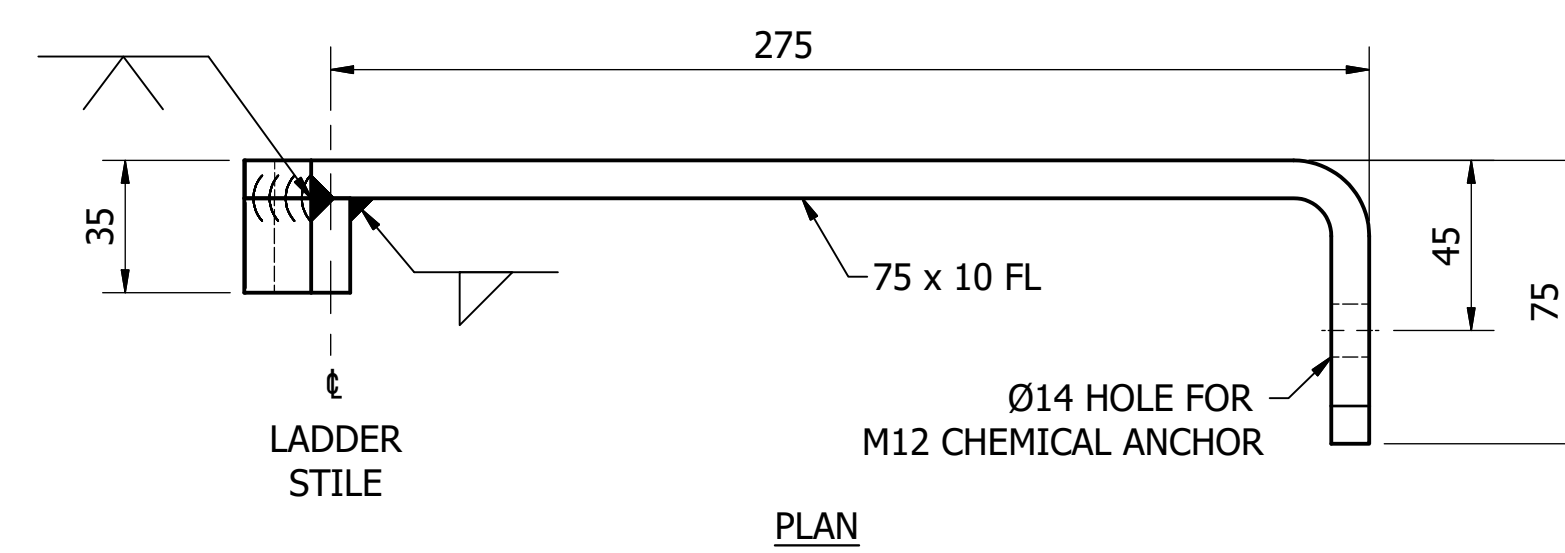

SIDE VIEW

**WALL BRACKET - INCLINED RUNG LADDER**

SCALE: 1 : 2

MATERIAL: CARBON STEEL  
 COATING: HOT DIP GALVANISED (AS PART OF LADDER ASSY.)  
 FINISH COLOUR: N/A  
 MASS: 2 kg

ITEM	AMDT.
PN815306	

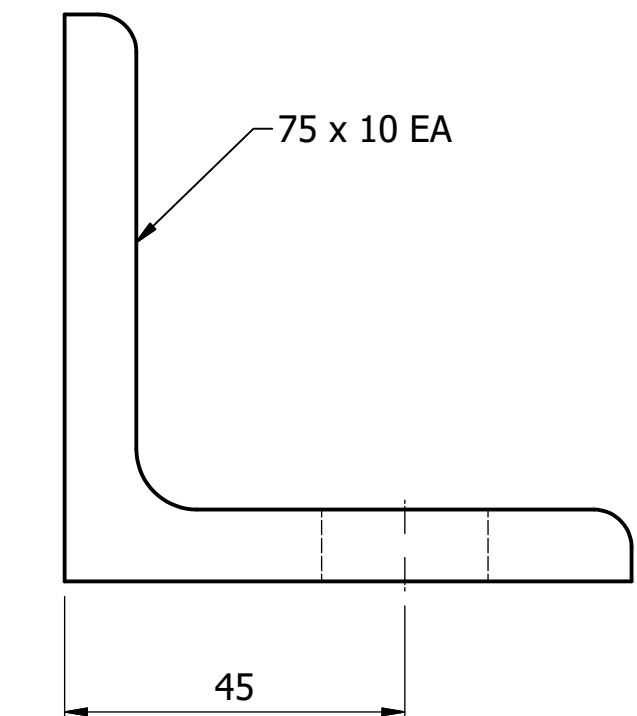
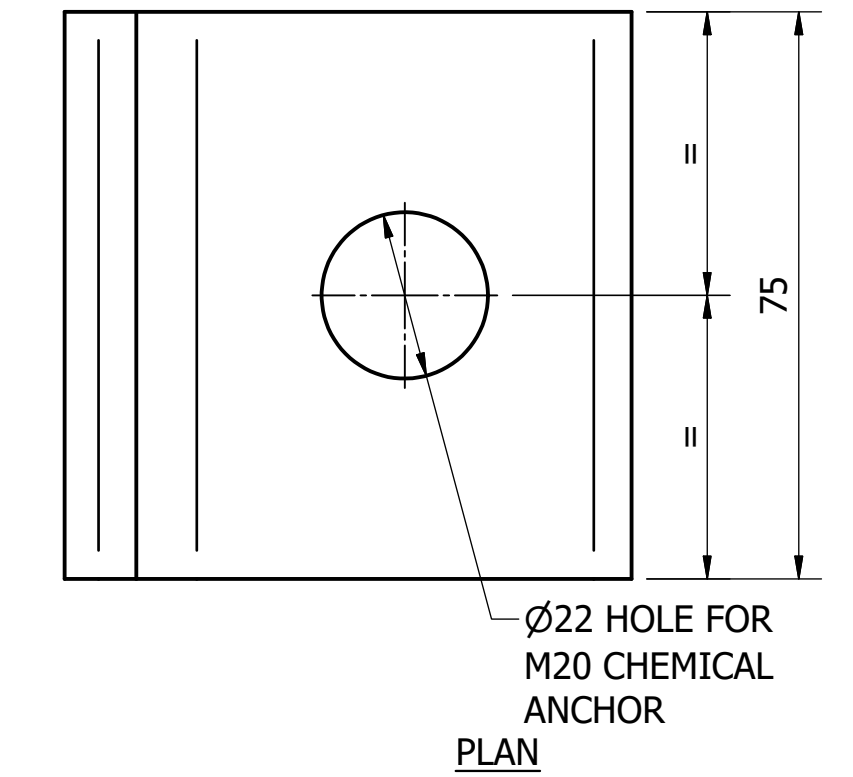

SIDE VIEW

**FLOOR BRACKET - INCLINED RUNG LADDER**

SCALE: 1 : 1

MATERIAL: CARBON STEEL  
 COATING: HOT DIP GALVANISED (AS PART OF LADDER ASSY.)  
 FINISH COLOUR: N/A  
 MASS: 1 kg

ITEM	AMDT.
PN815303	

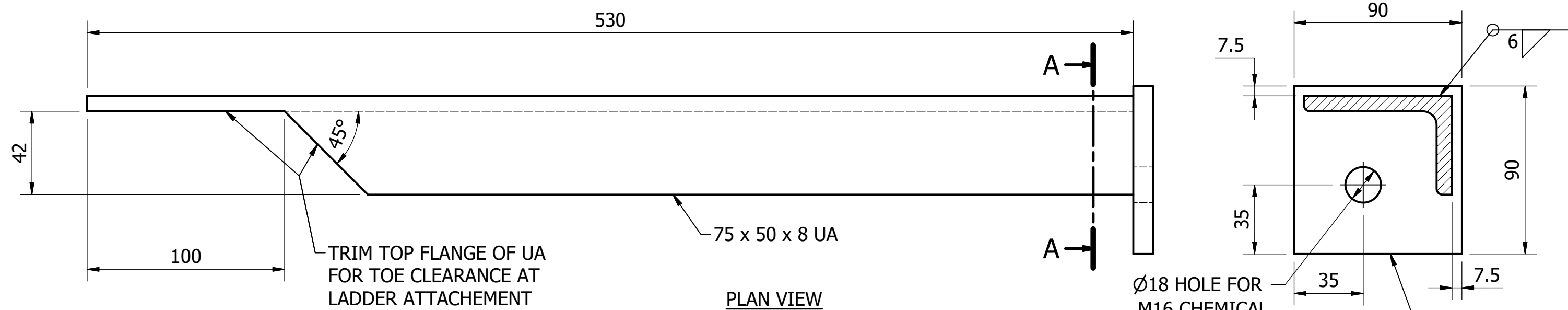

**WALL BRACKET (LONG) - INCLINED RUNG LADDER**

(FOR USE WITH INCLINED RUNG LADDER WITH EXTENDABLE STANCHIONS)

SCALE: 1 : 2

MATERIAL: CARBON STEEL  
 COATING: HOT DIP GALVANISED (AS PART OF LADDER ASSY.)  
 FINISH COLOUR: N/A  
 MASS: 5 kg

ITEM	AMDT.
PN815307	

RUNG DIMENSIONS		
LADDER TYPE	DIMENSION "A"	
VERTICAL RUNG WITH EXTENDABLE STANCHIONS	467	
VERTICAL RUNG LADDER FOR >= 1200 SEWER MH	387	
INCLINED RUNG LADDER WITH EXTENDABLE STANCHIONS	508	
INCLINED RUNG LADDER WITH FIXED STANCHIONS	545	

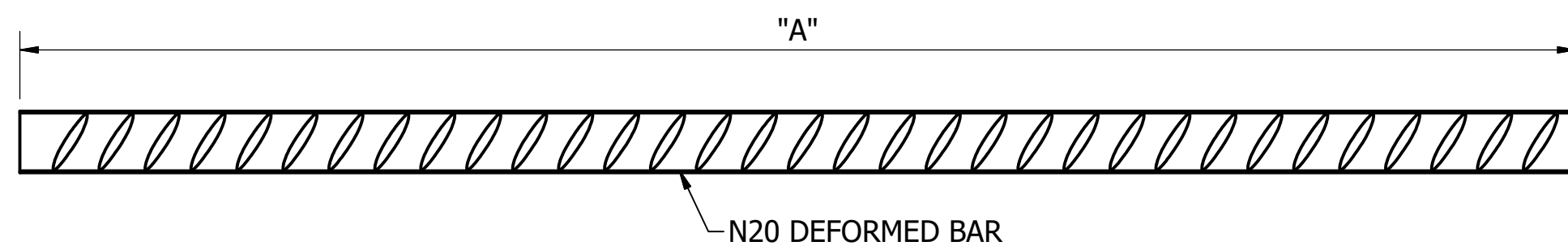

**RUNG - VERTICAL AND INCLINED RUNG LADDER**

SCALE: 1 : 2

MATERIAL: CARBON STEEL  
 COATING: HOT DIP GALVANISED (AS PART OF LADDER ASSY.)  
 FINISH COLOUR: N/A  
 MASS: 1.5 kg @ 545 LONG

ITEM	AMDT.
PN815304	

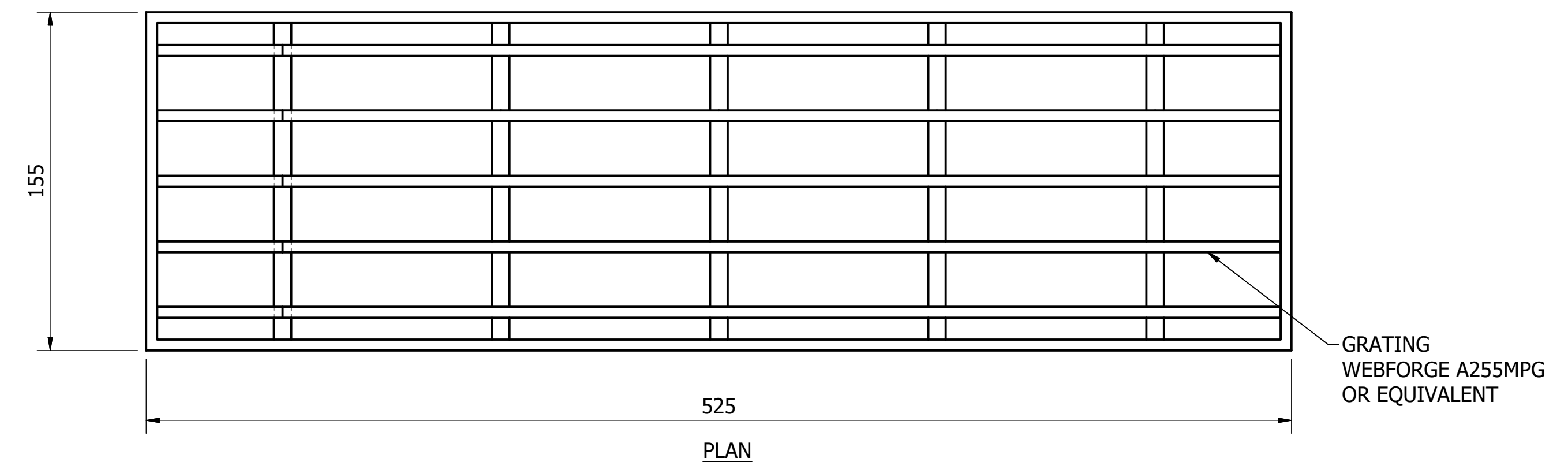

FRONT VIEW

**TREAD - INCLINED STEP LADDER**

SCALE: 1 : 2

MATERIAL: CARBON STEEL  
 COATING: HOT DIP GALVANISED (AS PART OF LADDER ASSY.)  
 FINISH COLOUR: N/A  
 MASS: 4 kg

ITEM	AMDT.
PN815305	

ASSET AREA APPLICABILITY				
DAM	RES	SPS	WAT	STP
BWS	WAT	SEW	REC	
WTP	SEW	REC		
WPS	REC			



STANDARD DRAWING  
 HOT DIP GALVANISED STEEL LADDERS  
 BRACKETS, RUNGS, TREADS AND FITTINGS  
 DETAILS

DRAWING STATUS

Current

SD-8153-D

A1

© Icon Water 2017

ISSUE A

No.	ISSUE	DATE	DRAWN	CHECKED	AUTHORISED
A	INITIAL ISSUE	15/06/2018	M. Matusiak	K. Danenbergson	D. Eager



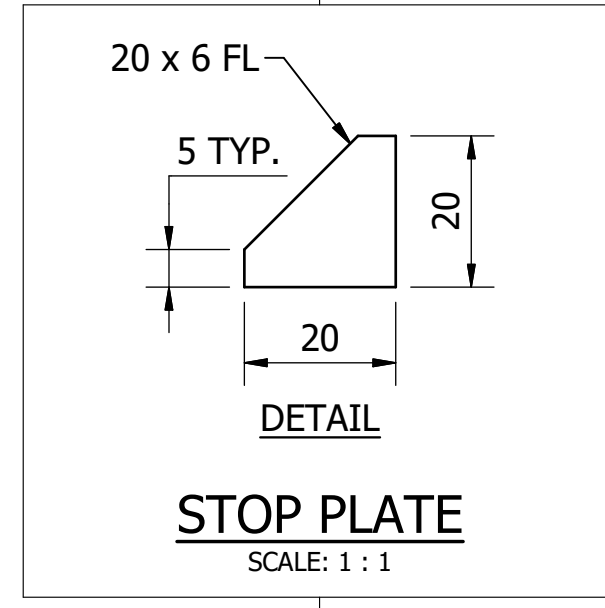
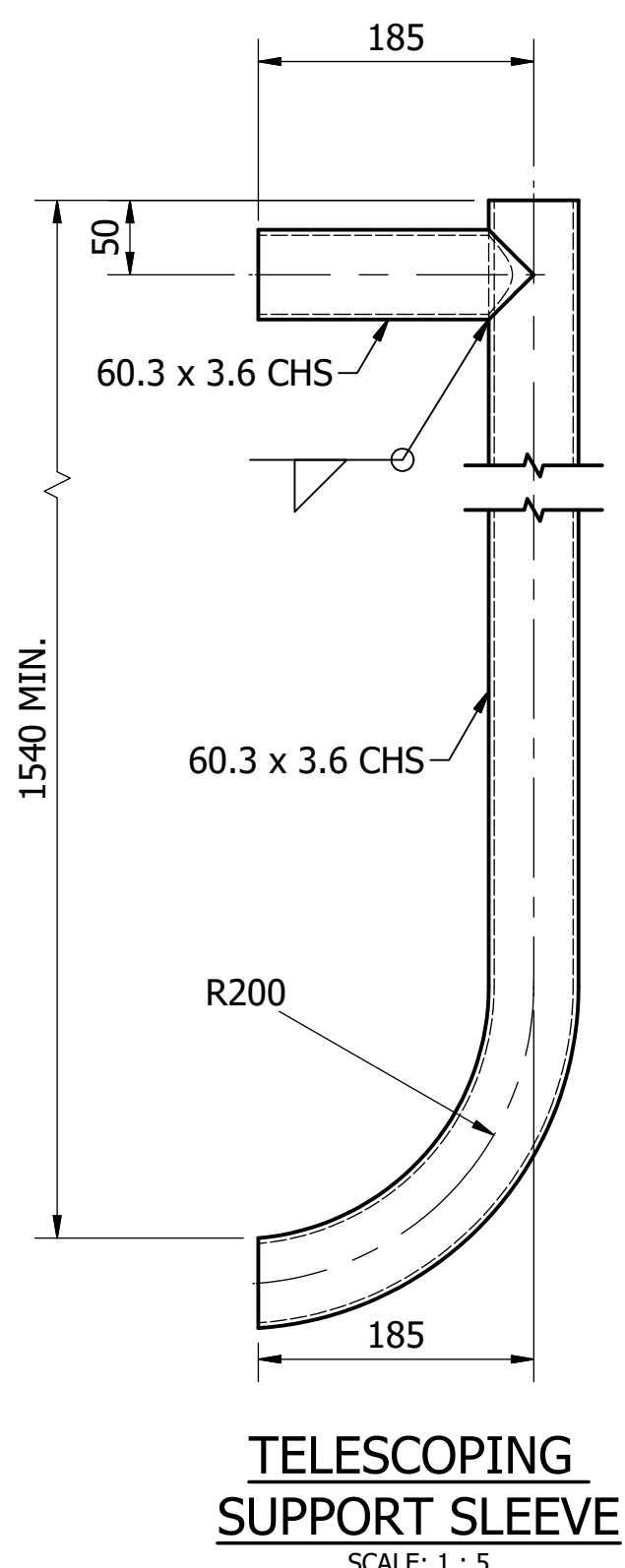
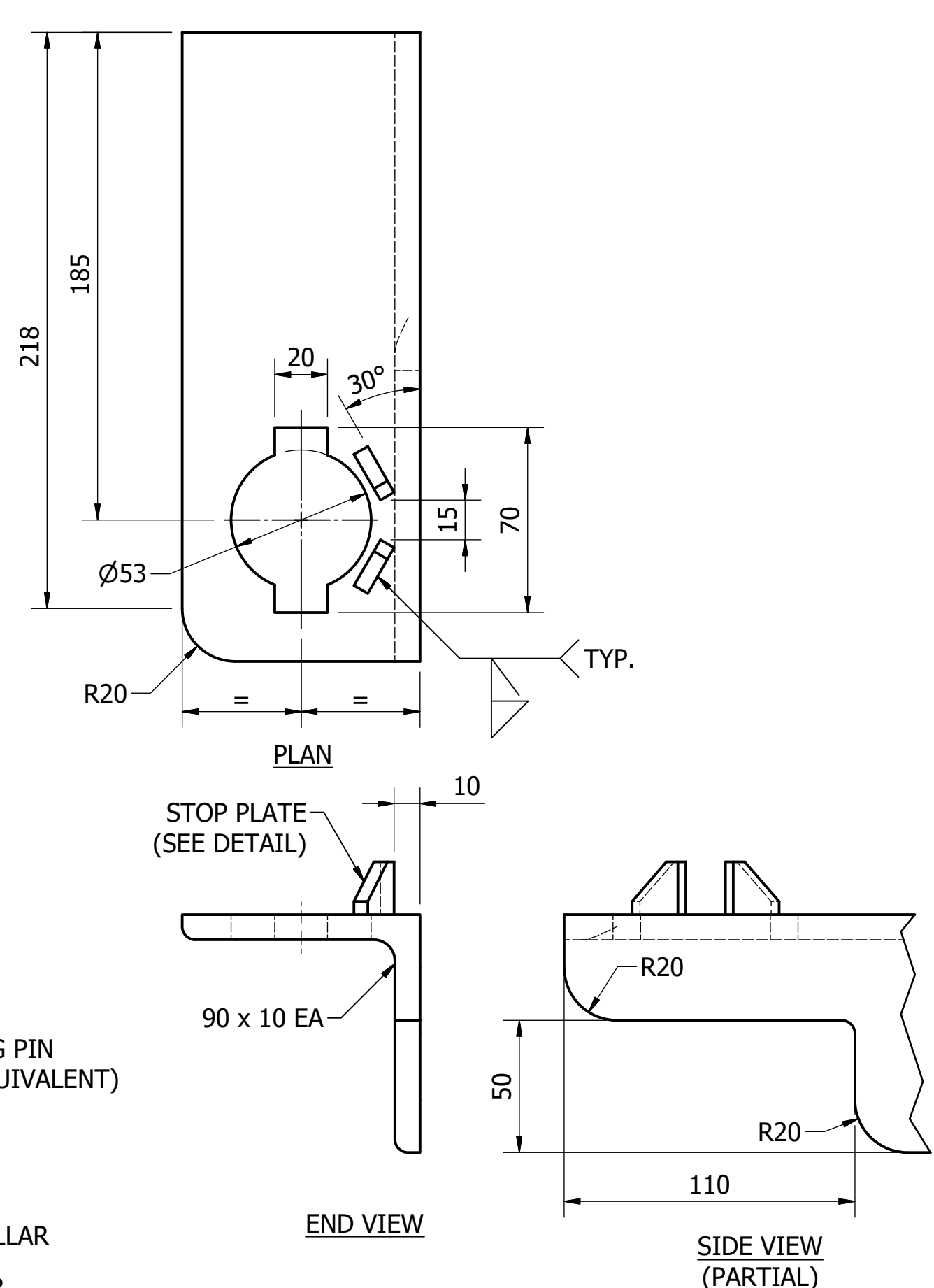
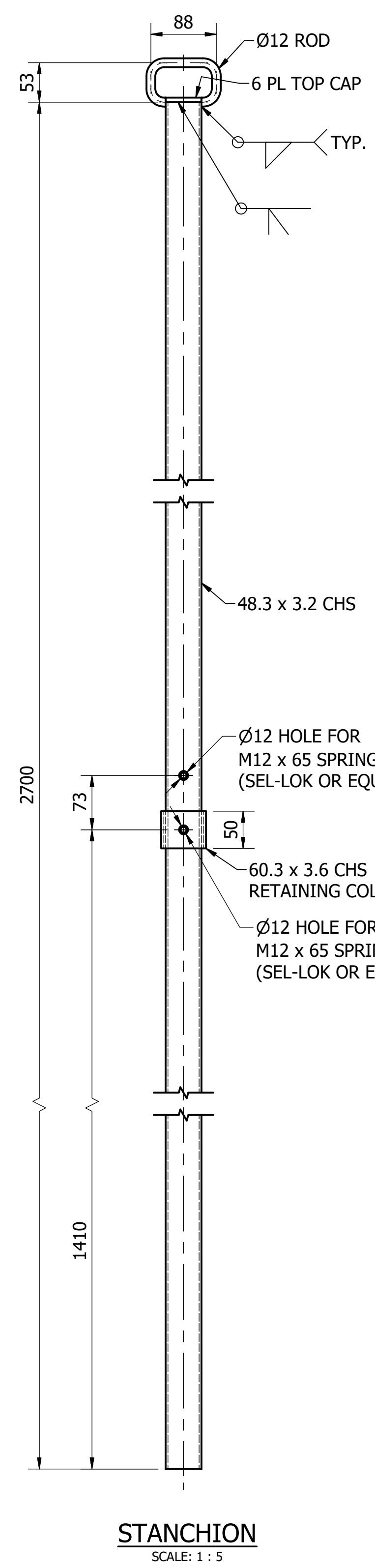
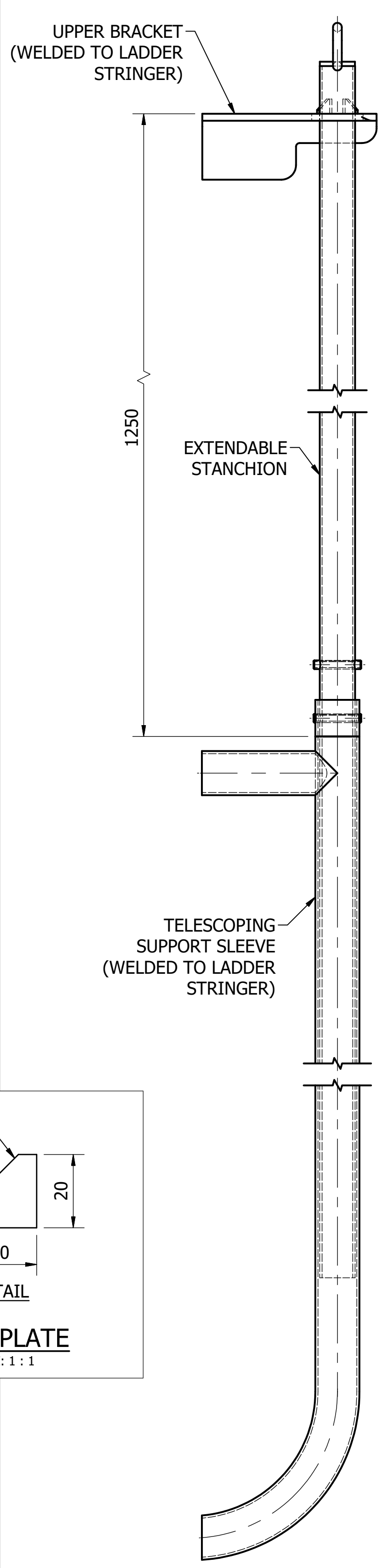
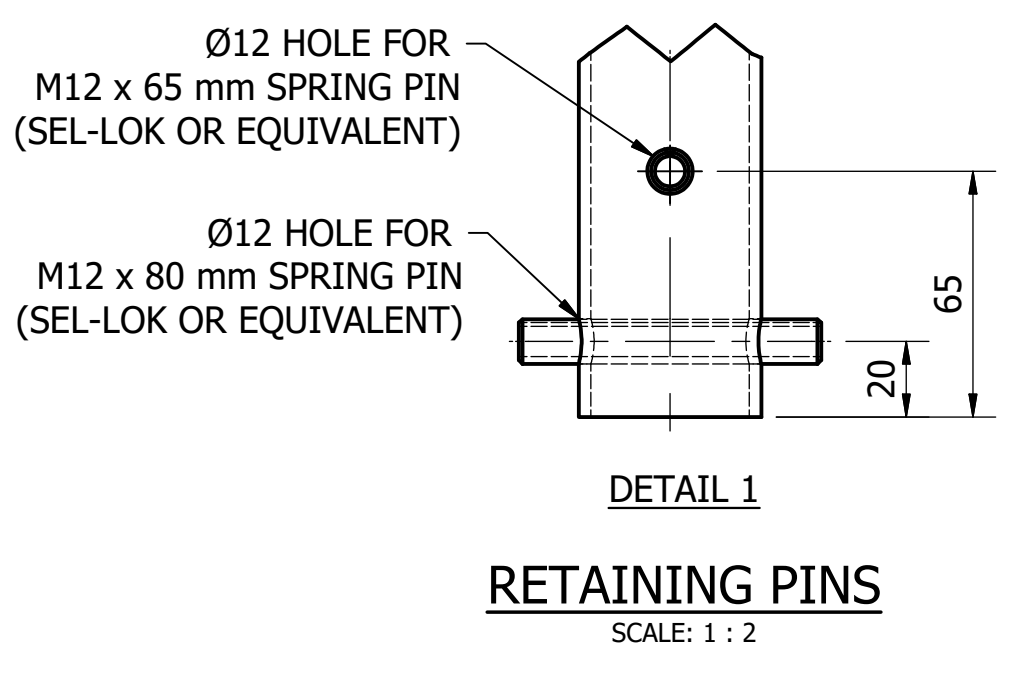
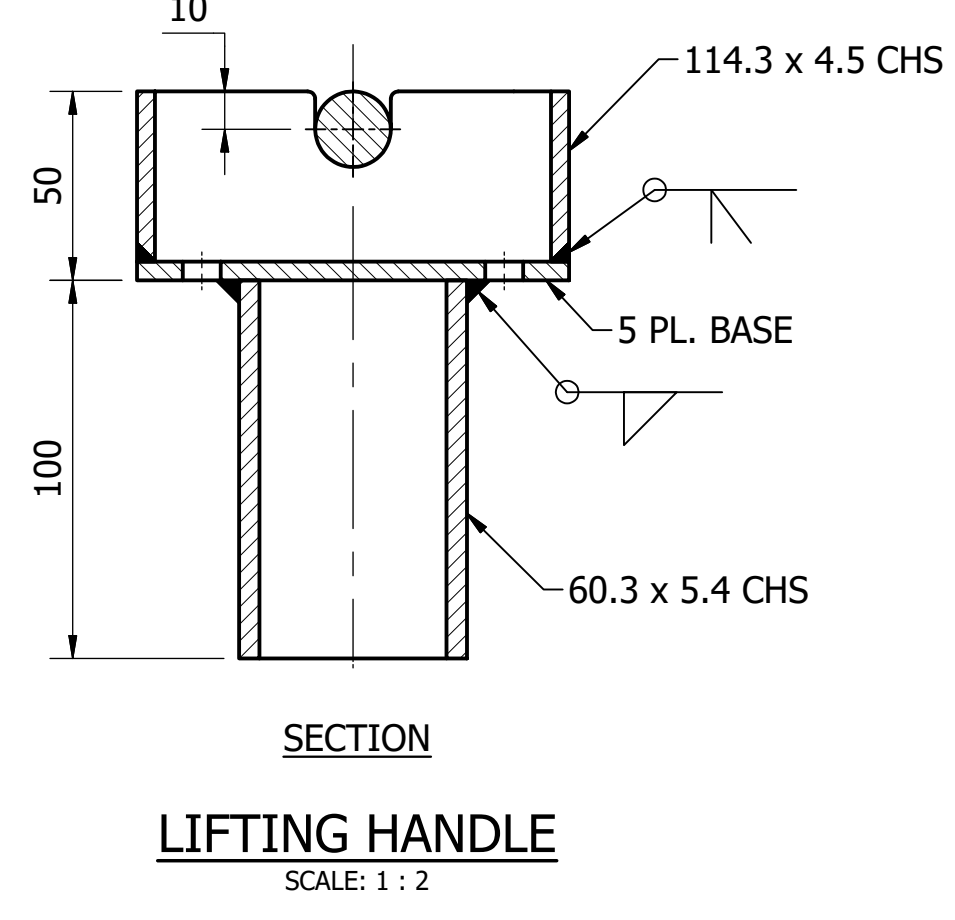
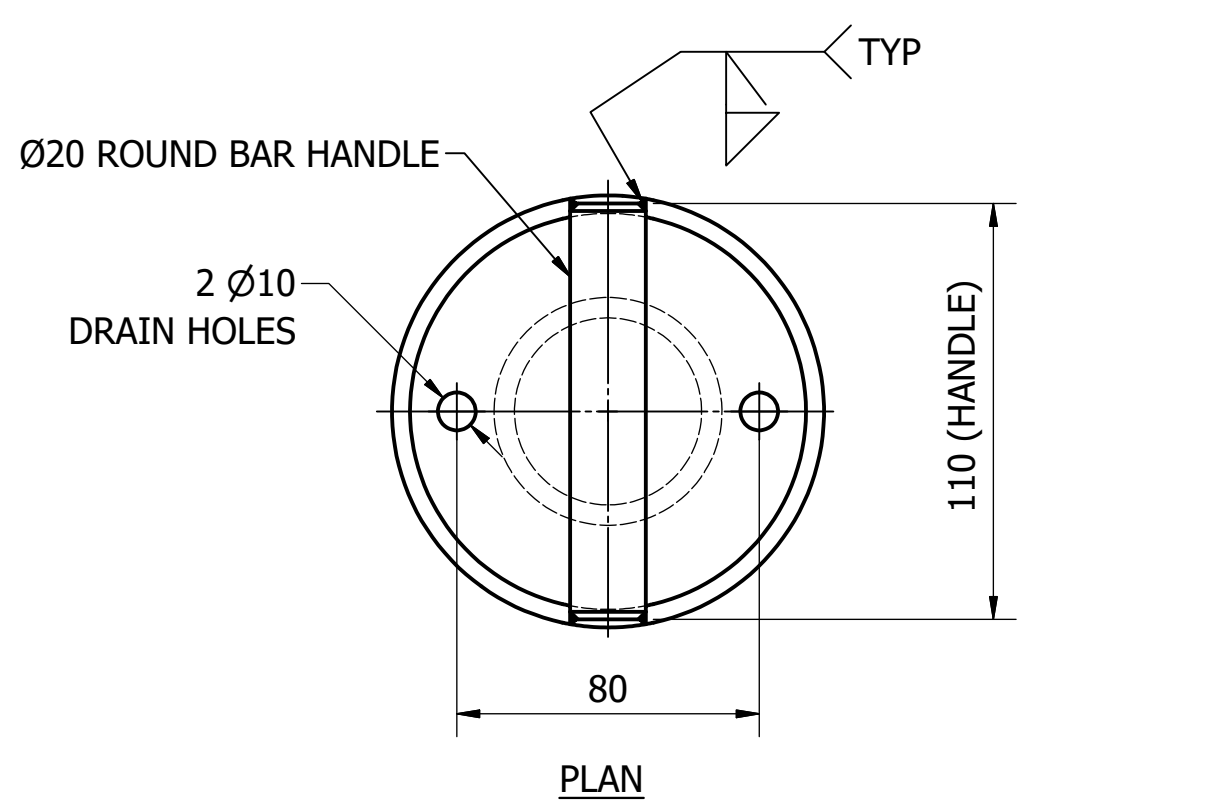
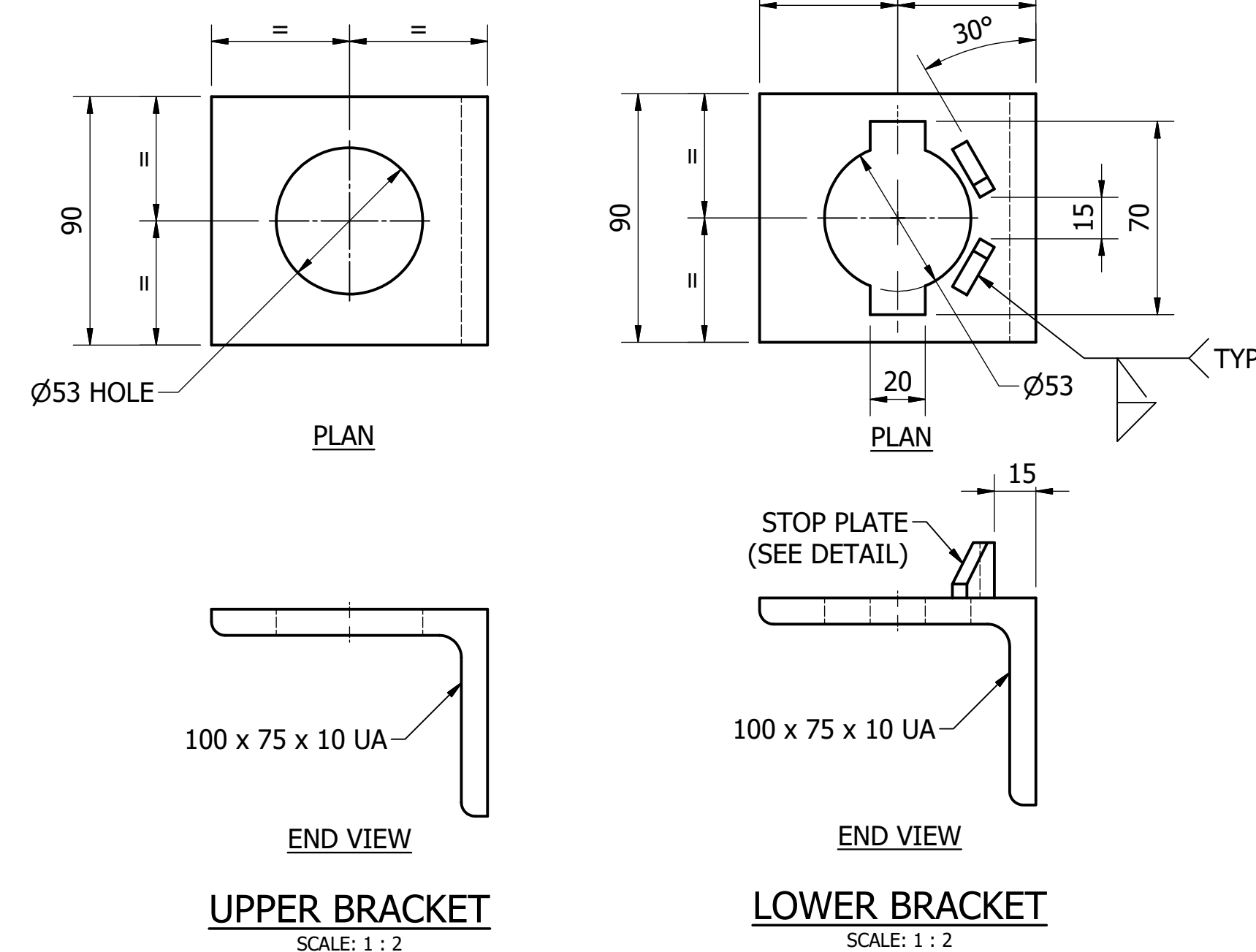
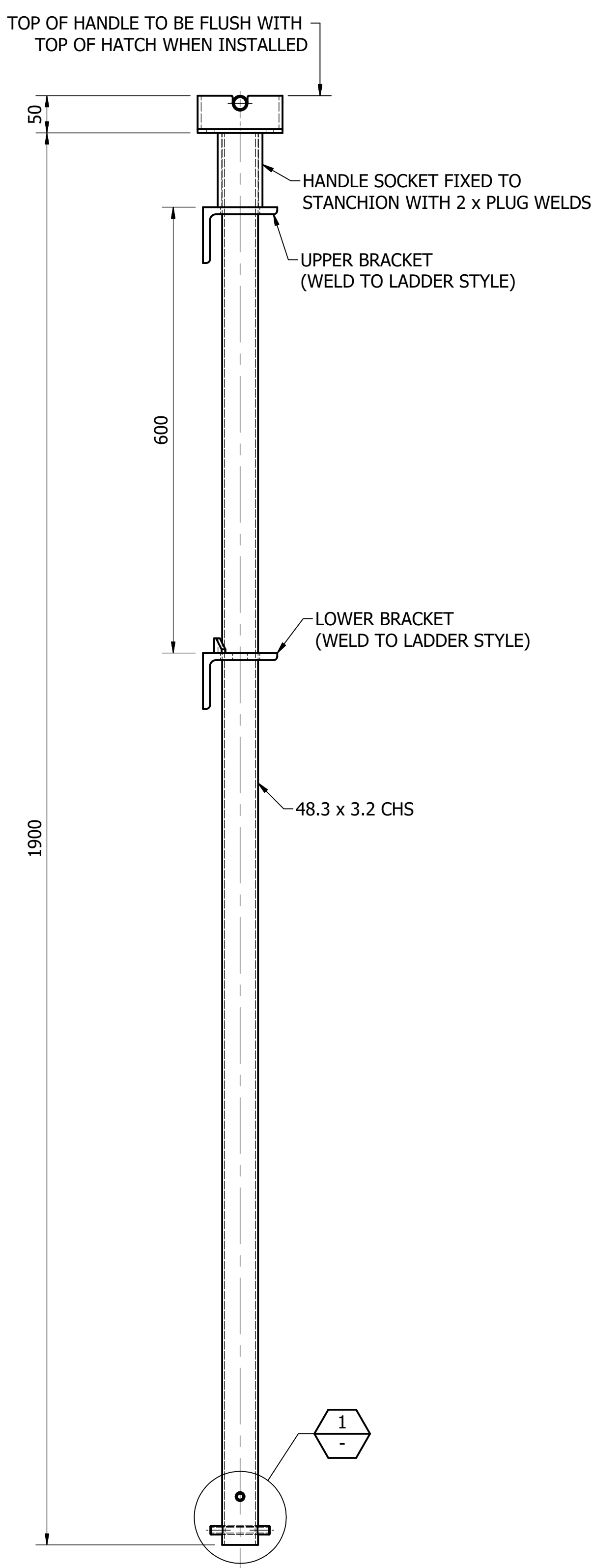

**EXTENDABLE STANCHION FOR VERTICAL LADDERS**  
(2 OFF REQ'D PER LADDER)  
SCALE: 1 : 5  
MATERIAL: CARBON STEEL  
COATING: HOT DIP GALVANISED  
FINISH COLOUR: N/A  
MASS: 11 kg

**EXTENDABLE STANCHION FOR INCLINED STEP LADDERS**  
(2 OFF REQ'D PER LADDER)  
SCALE: 1 : 5  
MATERIAL: CARBON STEEL  
COATING: HOT DIP GALVANISED  
FINISH COLOUR: N/A  
MASS: 22 kg

ITEM	AMDT.
PN815401	

ITEM	AMDT.
PN815402	

A	INITIAL ISSUE	15/06/2018	M. Matuziak	K. Danenbergsons	D. Eager
No.	ISSUE	DATE	DRAWN	CHECKED	AUTHORISED

DAM	RES	SPS
BWS	WAT	STP
WTP	SEW	
WPS	REC	

STANDARD DRAWING  
HOT DIP GALVANISED STEEL LADDERS  
STANCHIONS - EXTENDABLE  
DETAILS  
SHEET 1 OF 2

DRAWING STATUS	
Current	
SD-8154-D	
A1	ISSUE A



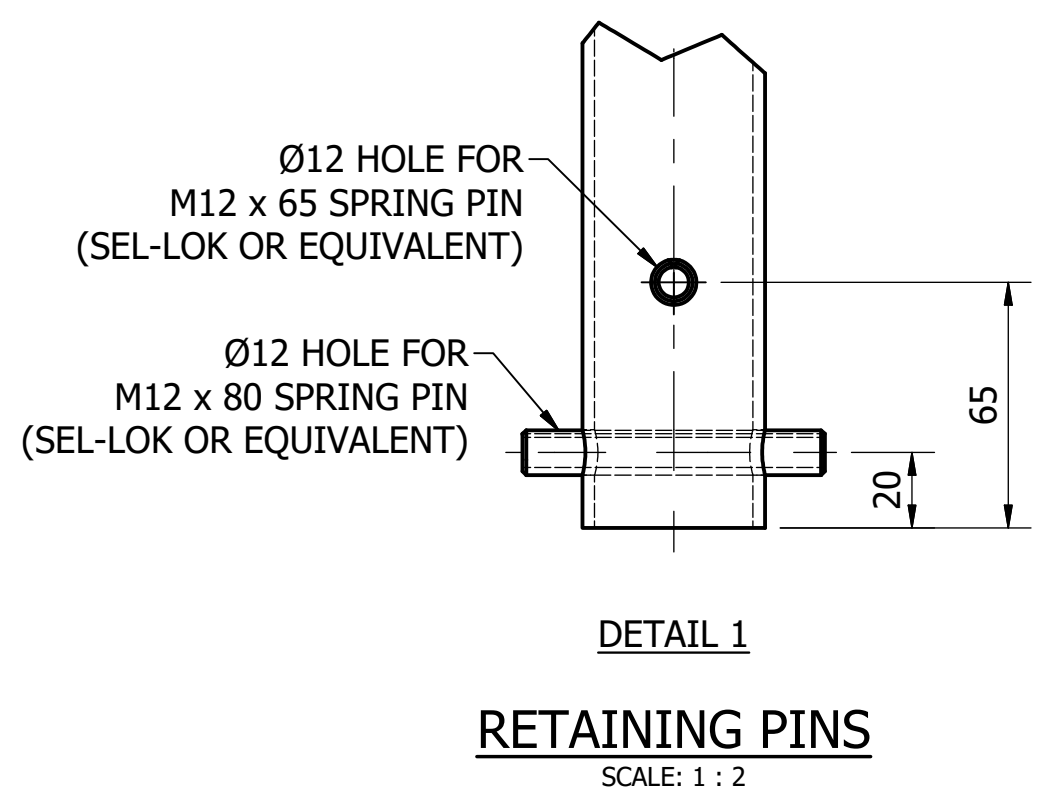
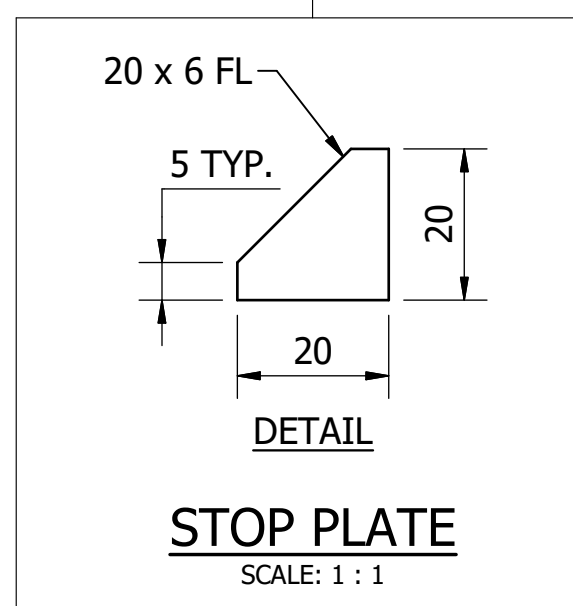
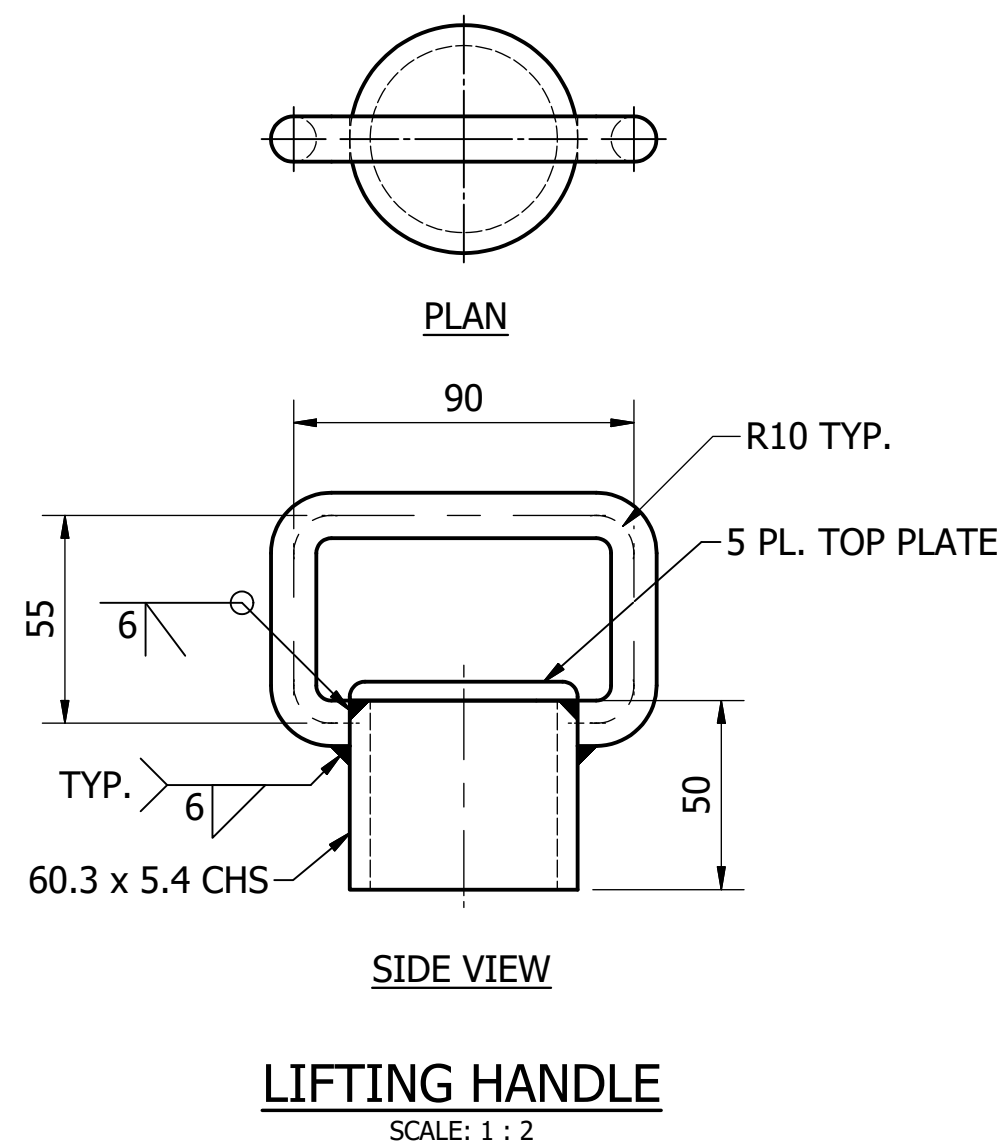
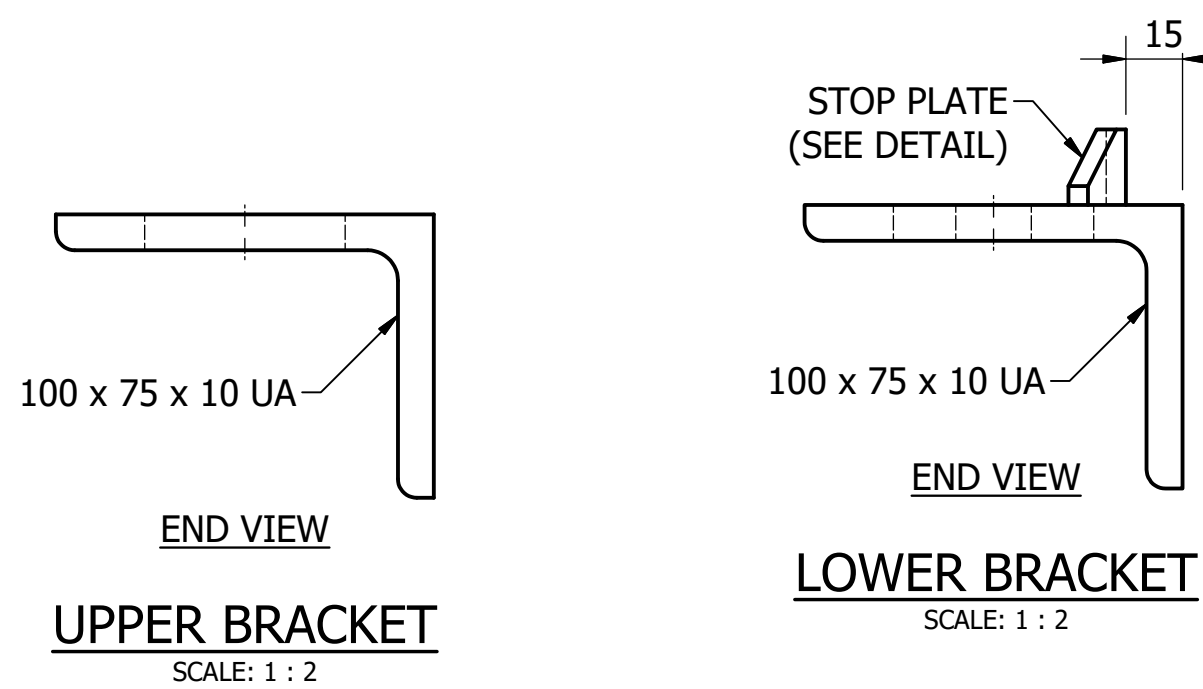
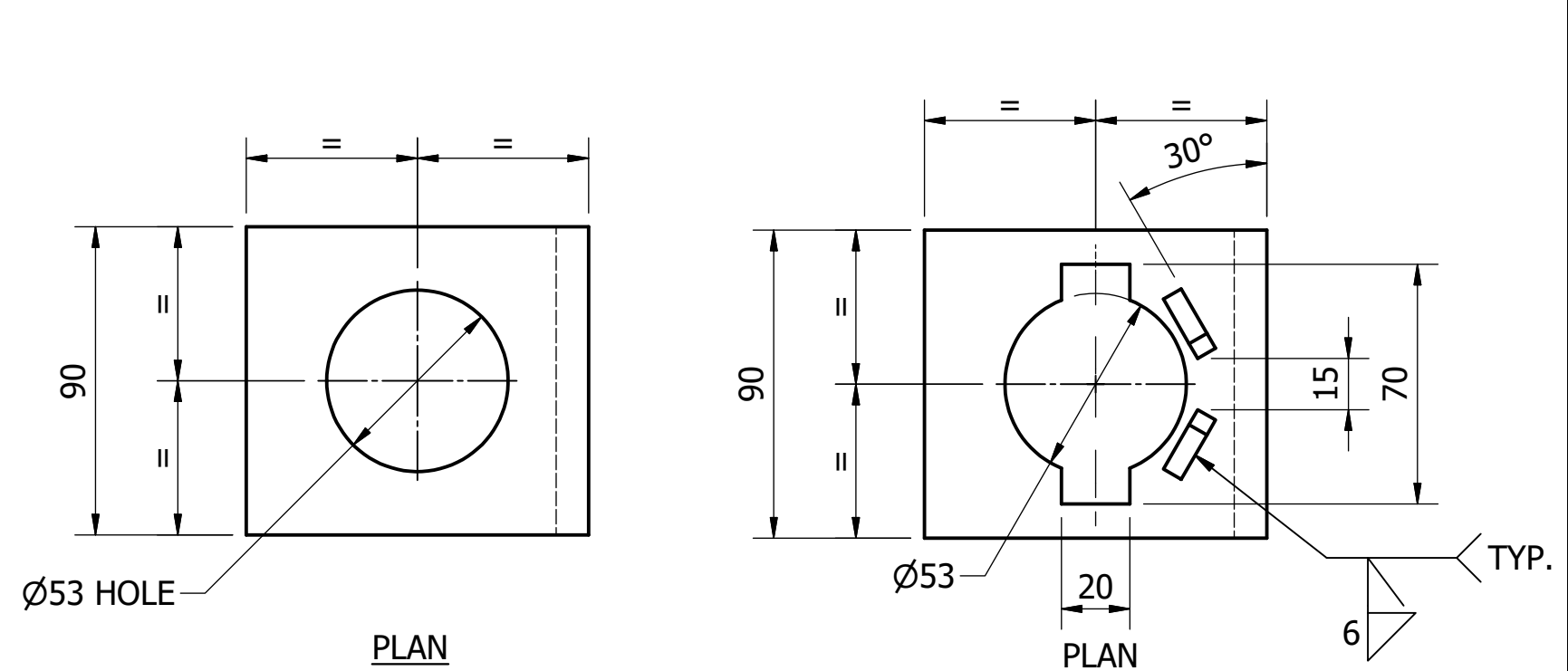
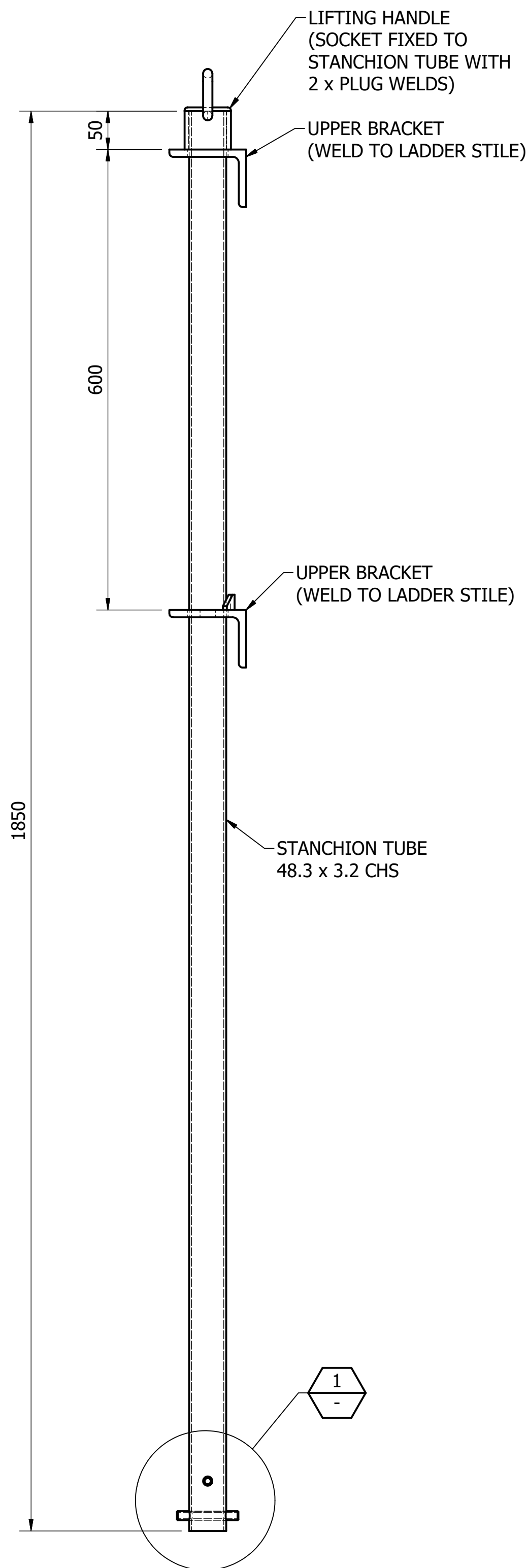

**EXTENDABLE STANCHION  
FOR INCLINED RUNG LADDERS**  
(2 OFF REQ'D PER LADDER)  
SCALE: 1 : 5

MATERIAL: CARBON STEEL  
COATING: HOT DIP GALVANISED  
FINISH COLOUR: N/A  
MASS: 10 kg

ITEM	AMDT.
PN815501	

No.	ISSUE	DATE	DRAWN	CHECKED	AUTHORISED
A	INITIAL ISSUE	15/06/2018	M. Matusiak	K. Danenbergsons	D. Eager

DAM	RES	SPS
BWS	WAT	STP
WTP	SEW	
WPS	REC	



STANDARD DRAWING  
HOT DIP GALVANISED STEEL LADDERS  
STANCHIONS - EXTENDABLE  
DETAILS  
SHEET 2 OF 2

DRAWING STATUS	
Current	
SD-8155-D	
A1	ISSUE A