

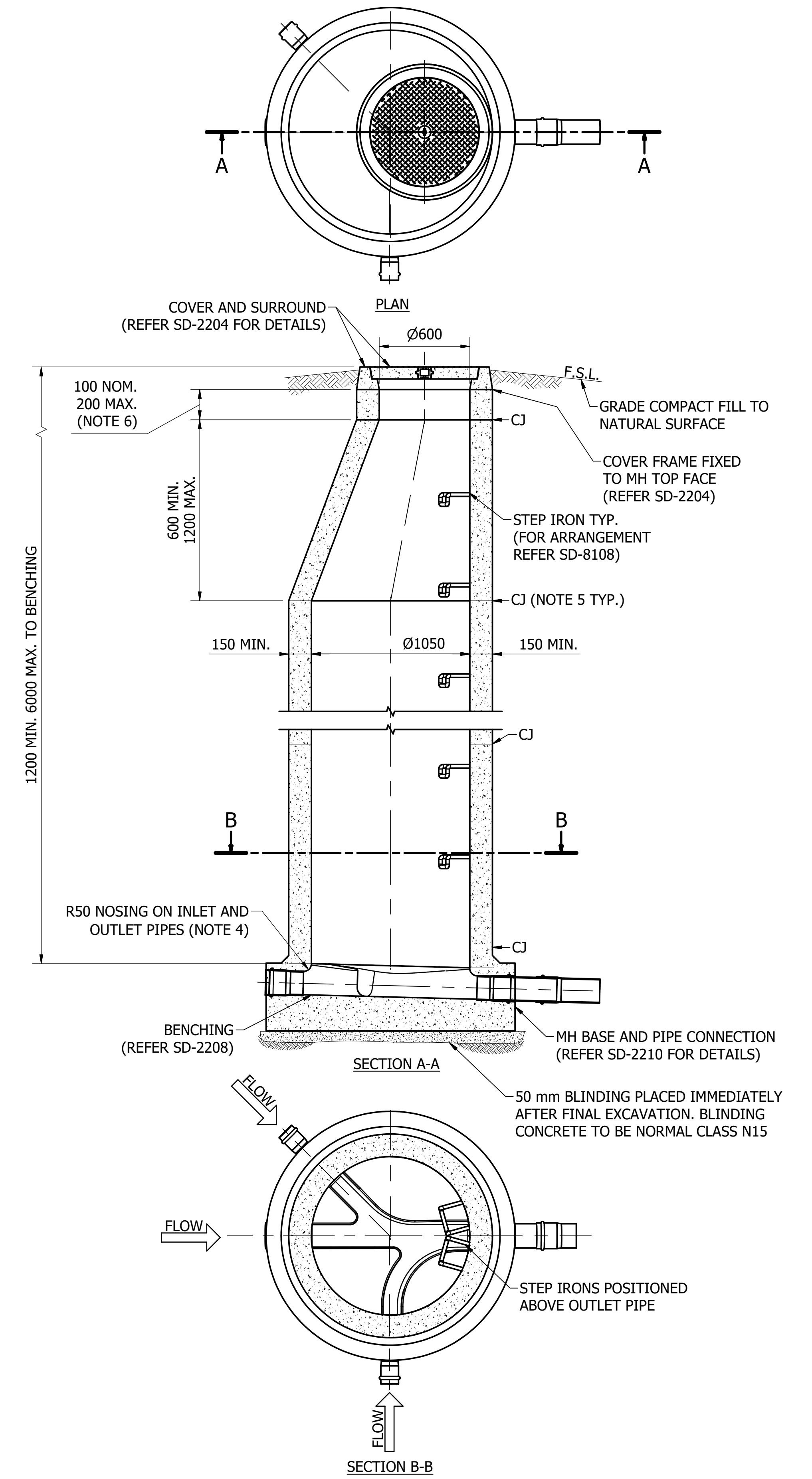

CUT-AWAY ISOMETRIC VIEW

NOTES:

1. DN1050 PRECAST MAINTENANCE HOLES SHALL NOT BE USED FOR DEPTHS (TO BENCHING) LESS THAN 1.2 m & GREATER THAN 6.0 m OR WHEN OUTLET SEWER DIAMETER IS LARGER THAN DN450. REFER TO SD-2206 FOR PRECAST MAINTENANCE HOLE DETAILS FOR DEPTHS < 1200 mm.
2. MIN CONCRETE GRADE SHALL BE 40 MPa.
3. MAINTENANCE HOLE INTERIOR FINISH TO BE CLASS 2 AND CLASS 3 TO AS 3600 ON WALLS AND ON BENCHING RESPECTIVELY. ALL FEATHERS, DAGS AND SHARP GRIT TO BE REMOVED.
4. FORM ROUNDED NOSING ON UPPER EDGE OF INLET AND OUTLET PIPES TO PREVENT FUTURE DAMAGE TO JETTING EQUIPMENT, CCTV GUIDES AND CABLES.
5. CONSTRUCTION JOINT DETAILS SHALL BE FULLY SPECIFIED BY THE DESIGNER ON THE PROJECT SPECIFIC DESIGN DRAWINGS.
6. NECK HEIGHT TO BE 100 mm WHEN MAINTENANCE HOLE IS POSITIONED IN ROAD PAVEMENTS TO ALLOW FOR FUTURE LEVEL ADJUSTMENT.
7. REFER SD-2208 FOR PERMISSABLE HORIZONTAL DEFLECTION.
8. NUMBER, SIZE AND LOCATION OF INLETS AND OUTLETS ARE INDICATIVE ONLY.



Ø1050 CAST IN SITU MAINTENANCE HOLE (SHOWN WITH BRANCHES) SCALE: 1 : 20

No.	ISSUE	DATE	DRAWN	CHECKED	AUTHORISED
A	INITIAL ISSUE	15/06/2018	M. Matusiak	K. Danenbergsons	D. Eager
B	NOTE 1 AMENDED. DRAWING NOW -D	18/06/2019	S. Essery	K. Danenbergsons	C. Patrick

ASSET AREA APPLICABILITY				
DAM	RES	SPS	X	
BWS	WAT	STP	X	
WTP	SEW		X	
WPS	REC			



STANDARD DRAWING
SEWERAGE NETWORK
CAST IN SITU MAINTENANCE HOLE
1050 DIA. WITH BRANCHES
ARRANGEMENT AND DETAILS

DRAWING STATUS		Current
SD-2201-D		ISSUE B
A1	© Icon Water 2017	

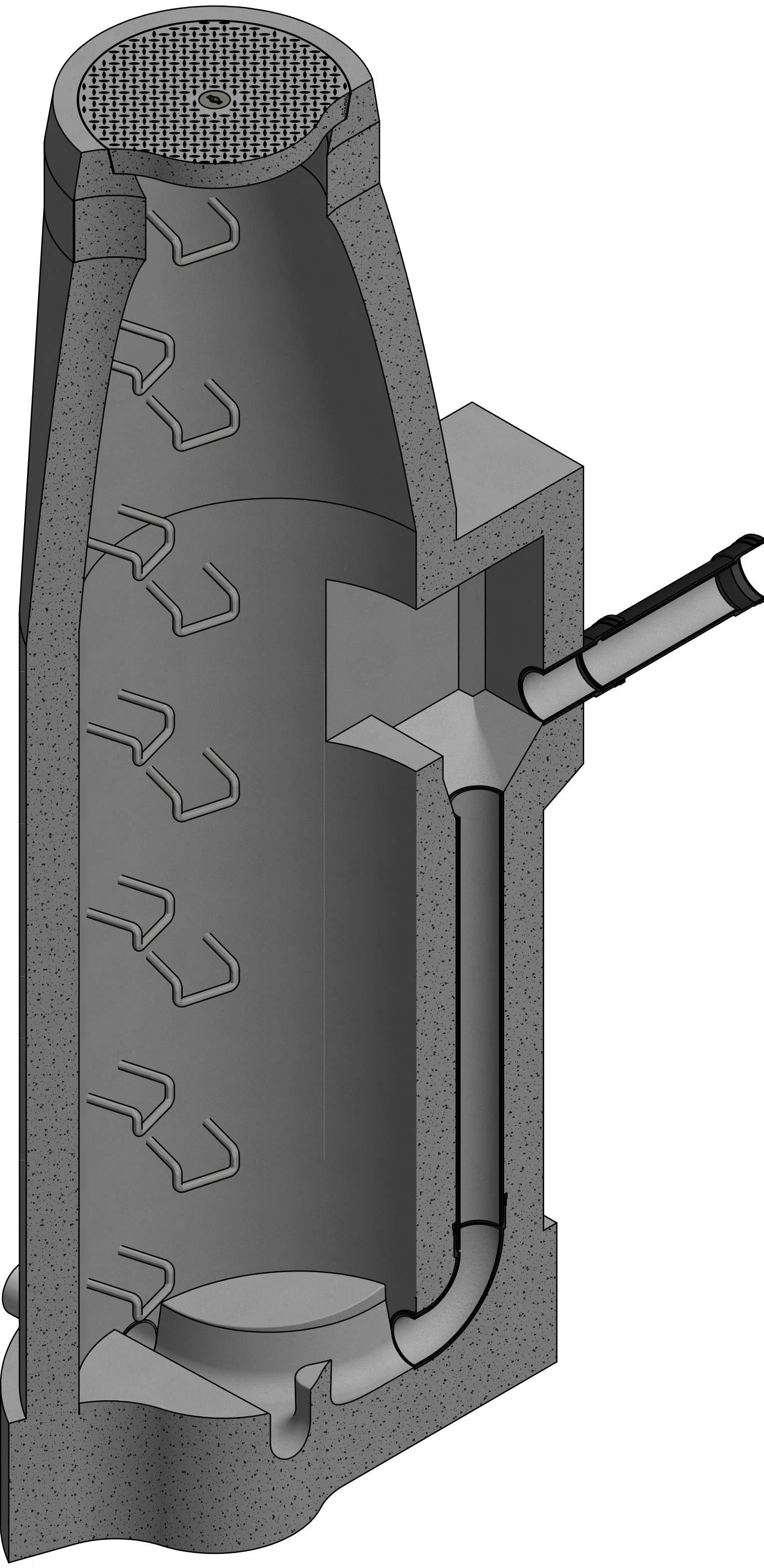

CUT-AWAY ISOMETRIC VIEW

MAINTENANCE HOLE WITH EXTERNAL DROP
SCALE: N.T.S.

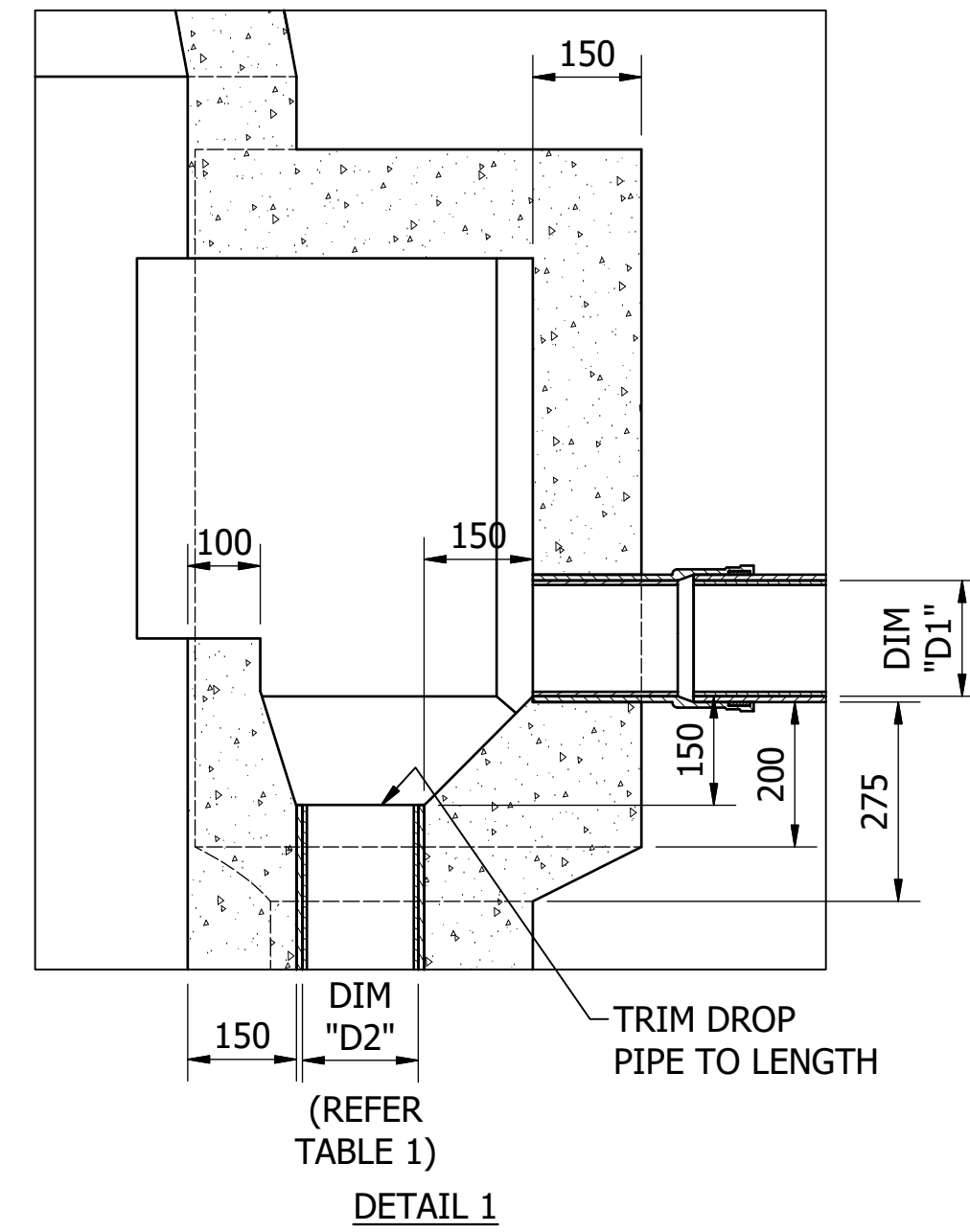

INLET CHAMBER AND WINDOW
SCALE: 1 : 10

TABLE 1: INLET DIAMETER AND DROP HEIGHT		
BRANCH DIA. "D1"	MIN. DROP PIPE DIA. "D2"	MIN. DROP HEIGHT "X"
150	150	450
225	150	450
300	225	560
375	300	680

TABLE 2: BENCHING DEPTH	
LARGEST INLET PIPE	BENCHING DEPTH
≤ DN375	TO OBVERT LEVEL (MAX. 400)
DN 450	400 MIN.
DN >450	1/2 D + 100 (400 MIN)

NOTES:

1. THE NOTES ON SD-2201 ARE ALSO APPLICABLE TO THIS DRAWING.
2. DETAILED CONSTRUCTION INFORMATION SUCH AS CONSTRUCTION JOINTS HAVE NOT BEEN SHOWN. THESE DETAILS SHALL BE PROVIDED BY THE DESIGNER ON THE PROJECT SPECIFIC DRAWINGS.

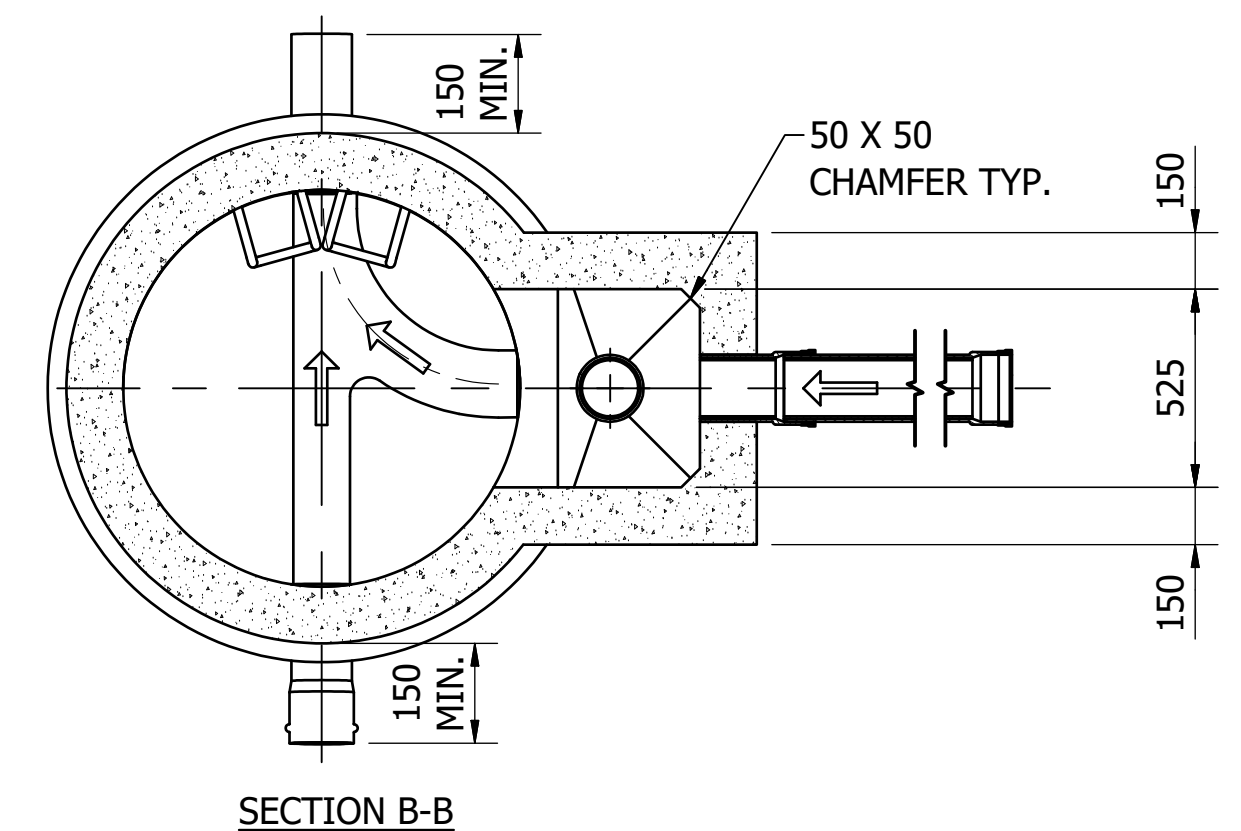
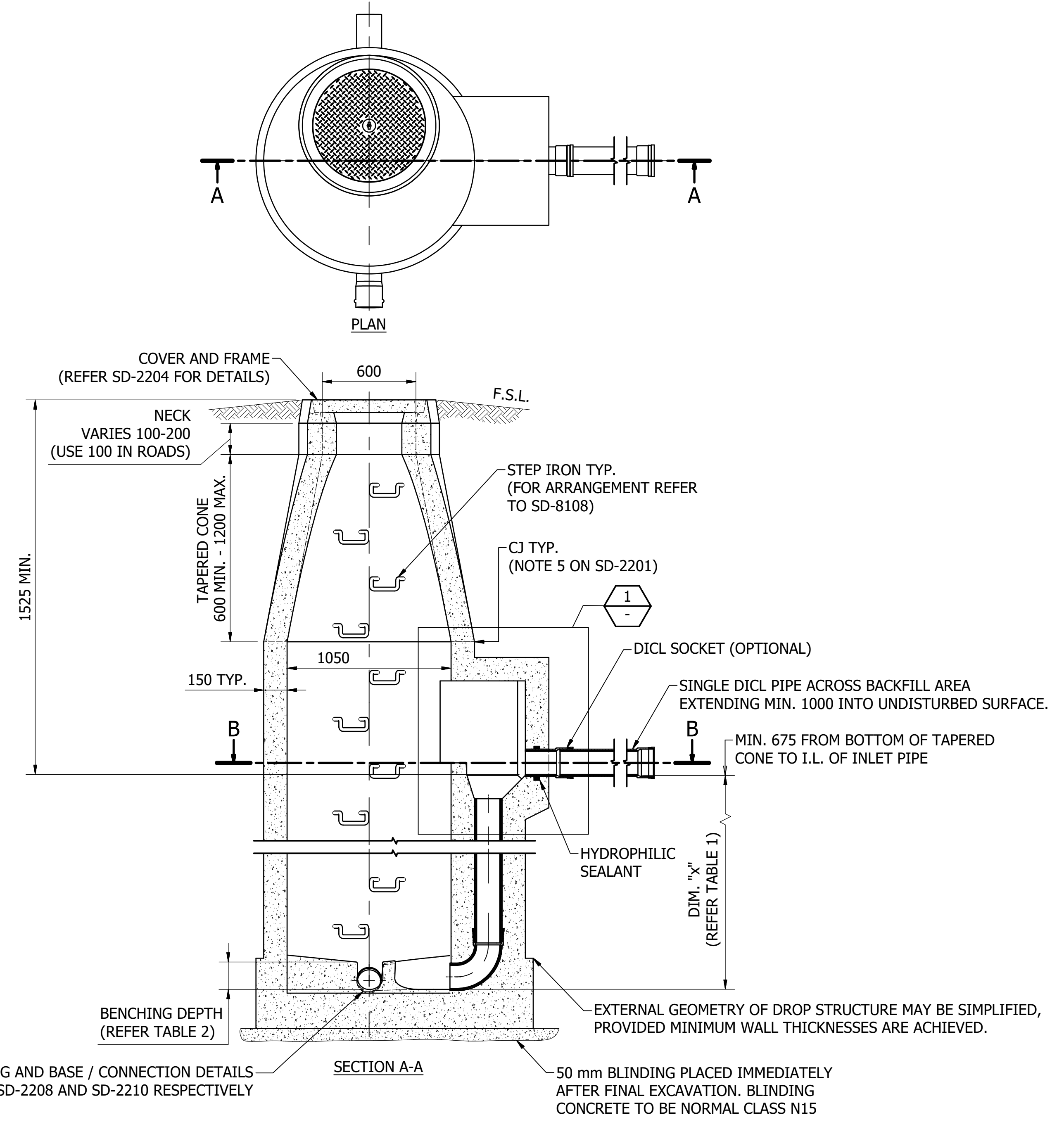

MAINTENANCE HOLE WITH EXTERNAL DROP
SCALE: 1 : 20

DAM	RES	SPS	X
BWS	WAT	STP	X
WTP	SEW		X
WPS	REC		
ASSET AREA APPLICABILITY			



STANDARD DRAWING
SEWERAGE NETWORK
CAST IN SITU MAINTENANCE HOLE
1050 DIA. WITH EXTERNAL DROP
ARRANGEMENT AND DETAILS

DRAWING STATUS		Current
SD-2202-D		ISSUE B
A1	© Icon Water 2017	

No.	ISSUE	DATE	DRAWN	CHECKED	AUTHORISED
A	INITIAL ISSUE	15/06/2018	M. Matusiak	K. Danenbergson	D. Eager
B	DRAWING CHANGED TO -D	18/06/2019	S. Essery	K. Danenbergson	C. Patrick

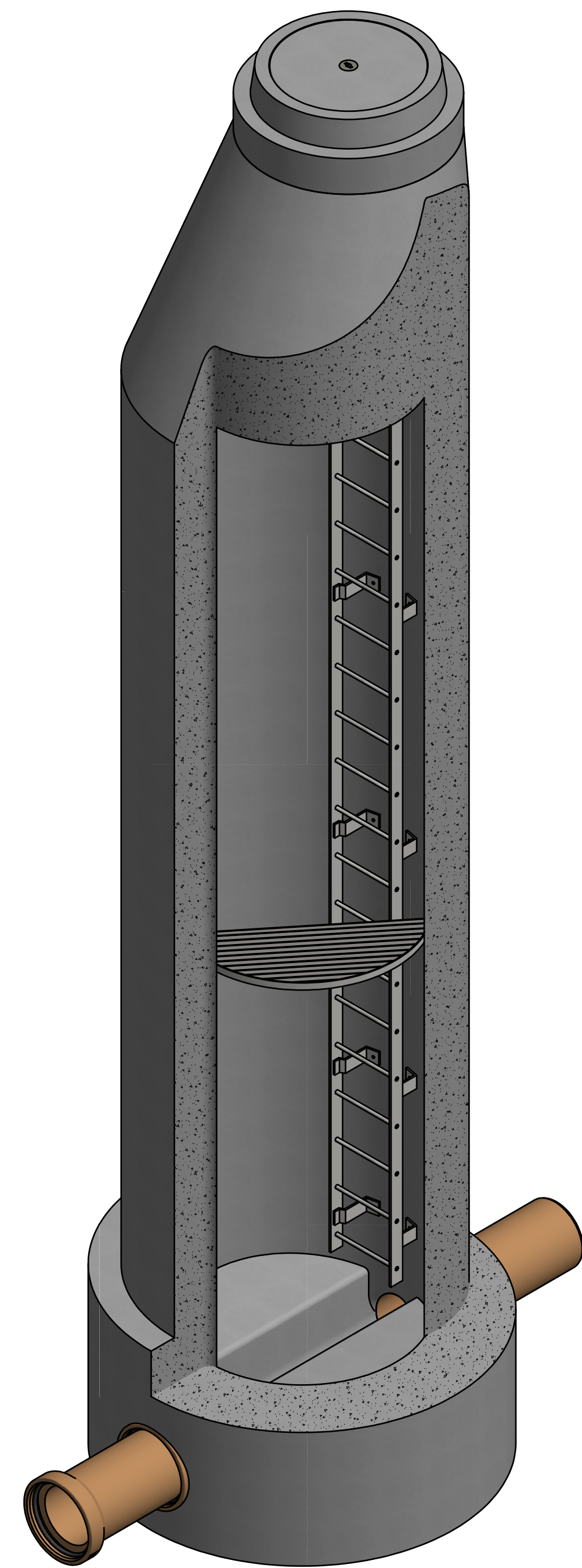

CUT-AWAY ISOMETRIC VIEW
SCALE: N.T.S.

NOTES:

1. DN1200 OR LARGER MAINTENANCE HOLES TO BE USED WHEN:
- SEWER SIZE DN525 TO DN675, OR
- MH DEPTH TO INVERT 6.0 m TO 8.0 m.
2. MIN CONCRETE GRADE SHALL BE 40 MPa.
3. MAINTENANCE HOLE INTERIOR FINISH TO BE CLASS 2 AND CLASS 3 TO AS 3600 ON WALLS AND ON BENCHING RESPECTIVELY. ALL FEATHERS, DAGS AND SHARP GRIT TO BE REMOVED.
4. FORM ROUNDED NOSING ON UPPER EDGE OF INLET AND OUTLET PIPES TO PREVENT FUTURE DAMAGE TO JETTING EQUIPMENT, CCTV GUIDES AND CABLES.
5. CONSTRUCTION JOINT DETAILS SHALL BE FULLY SPECIFIED BY THE DESIGNER ON THE PROJECT SPECIFIC DESIGN DRAWINGS.
6. INTERMEDIATE LANDING TO BE CONSTRUCTED OF "WEBFORGE" C325 STAINLESS STEEL GRATING (OR APPROVED EQUIVALENT) BANDED ALL-ROUND. GRATING TO BE FIXED WITH 316 STAINLESS STEEL ANGLE SUPPORT AND CHEMICAL ANCHORS. THE DESIGNER SHALL SPECIFY THE DETAILS ON THE PROJECT SPECIFIC DESIGN DRAWINGS. THE INTERMEDIATE LANDING SHALL BE LOCATED SUCH THAT OVERFLOW FROM ANY VERTICAL DROP IS AVOIDED.
7. MAKEUP RING TO BE 100 HIGH WHEN MAINTENANCE HOLE IS POSITIONED IN ROAD PAVEMENTS TO ALLOW FOR FUTURE LEVEL ADJUSTMENT.
8. WALL THICKNESS SHALL BE 150 FOR MAINTENANCE HOLE DEPTHS LESS THAN 6000 AND DN NOT EXCEEDING 1200; 225 FOR MAINTENANCE HOLE DEPTHS BETWEEN 6000 AND 8000. FOR LARGER DIAMETERS, STRUCTURE TO BE DESIGNED IN ACCORDANCE WITH AS 1170 AND AS 3735.
9. WHERE LADDER IS LOCATED OVER BENCHING, MAINTENANCE HOLE TO BE OFFSET TO PROVIDE 150 BENCH WIDTH ON SIDE OPPOSITE LADDER.
10. INTERMEDIATE LANDING REQUIRED FOR MAINTENANCE HOLES WITH DEPTH TO INVERT > 6 m.

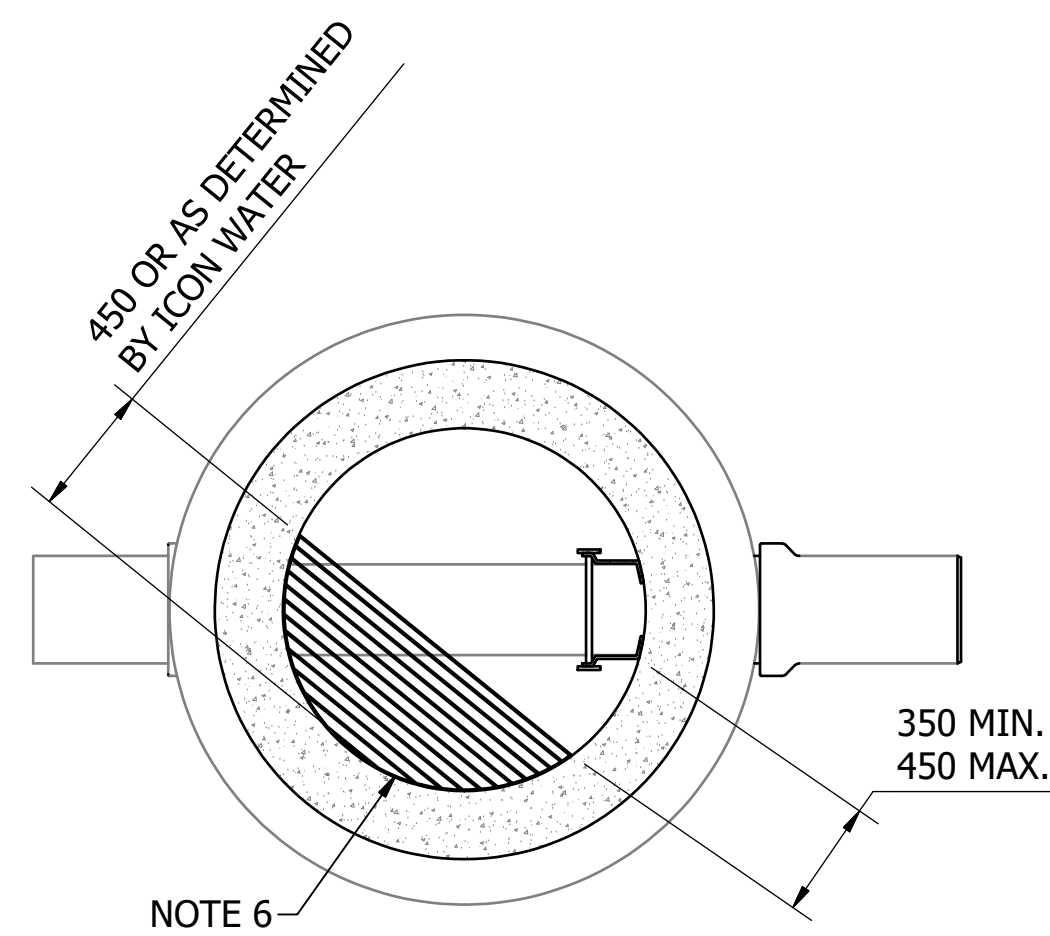

DETAIL 1
INTERMEDIATE LANDING
SCALE: 1 : 25

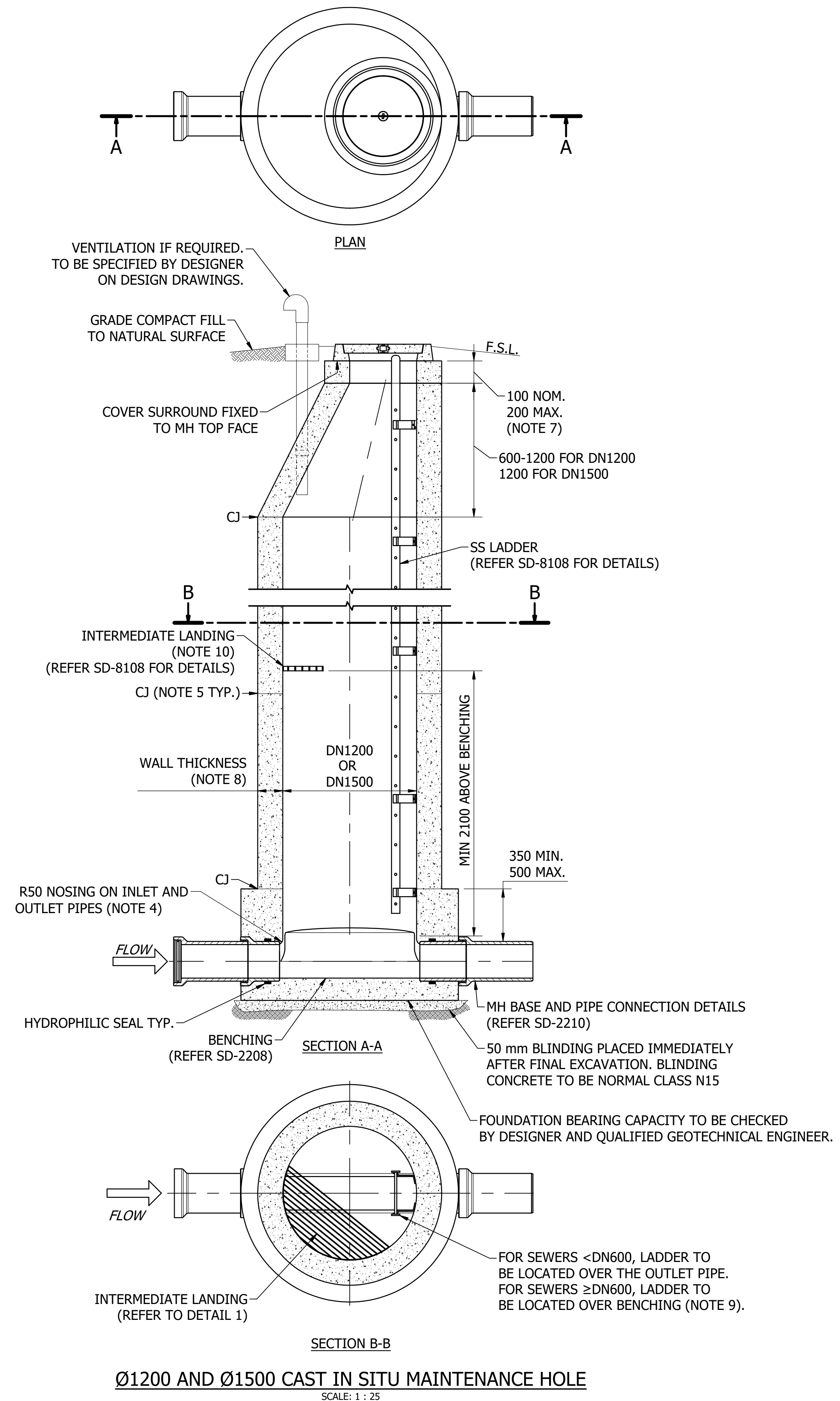

Ø1200 AND Ø1500 CAST IN SITU MAINTENANCE HOLE
SCALE: 1 : 25

No.	ISSUE	DATE	DRAWN	CHECKED	AUTHORISED
A	INITIAL ISSUE	15/06/2018	M. Matusiak	K. Danenbergsons	D. Eager
B	MODEL CORRECTION & DRAWING CHANGED TO -D	18/06/2019	S. Essery	K. Danenbergsons	C. Patrick

DAM	RES	SPS	STP
WTP	SEW		
WPS	REC		



STANDARD DRAWING
SEWERAGE NETWORK
CAST IN SITU MAINTENANCE HOLES
1200 DIA. TO 1500 DIA.
ARRANGEMENT AND DETAILS

DRAWING STATUS		Current
SD-2203-D		ISSUE B
A1	© Icon Water 2017	

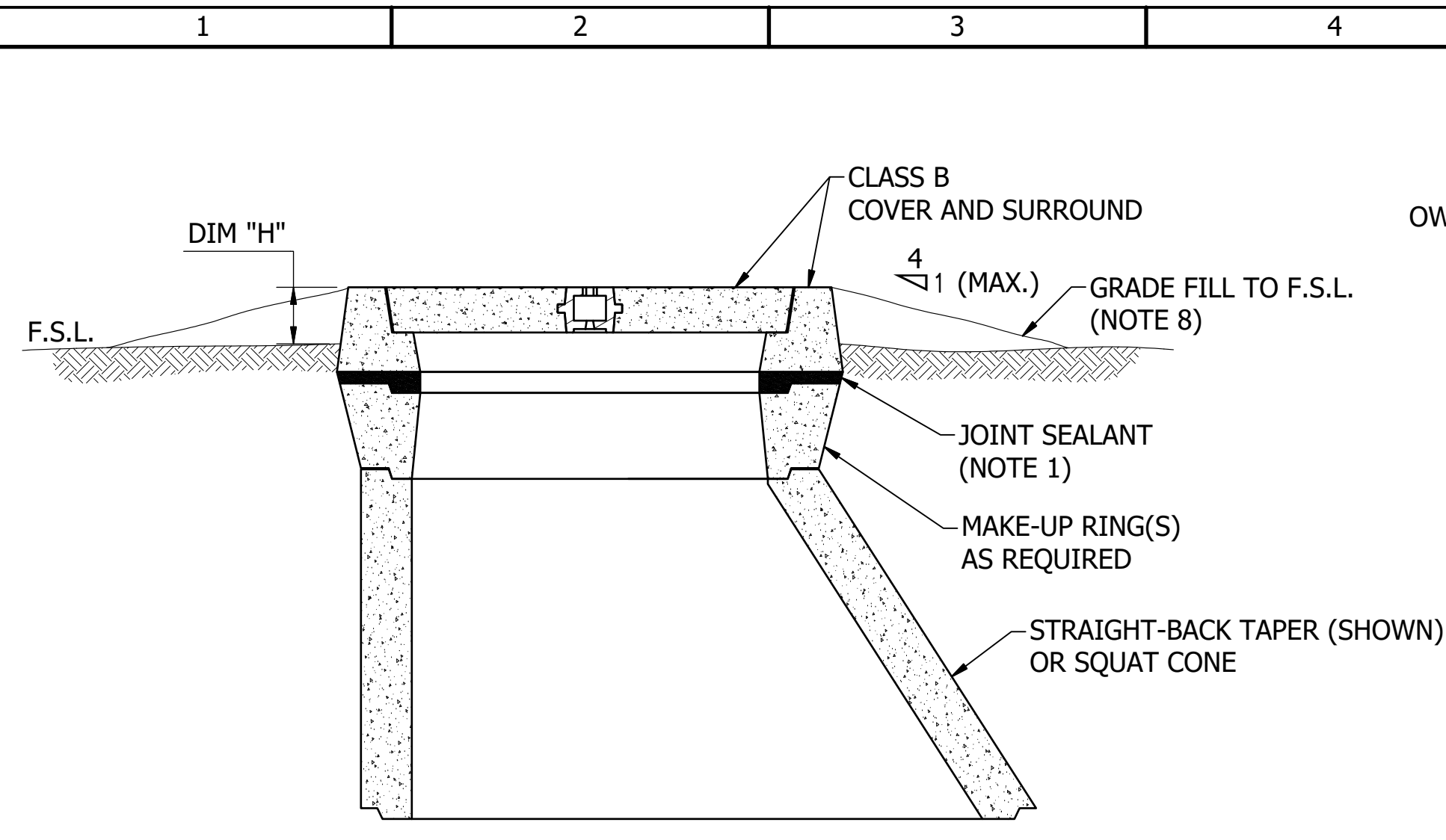

**PRECAST MAINTENANCE HOLE
NON-TRAFFICABLE AREA**
SCALE: 1 : 10

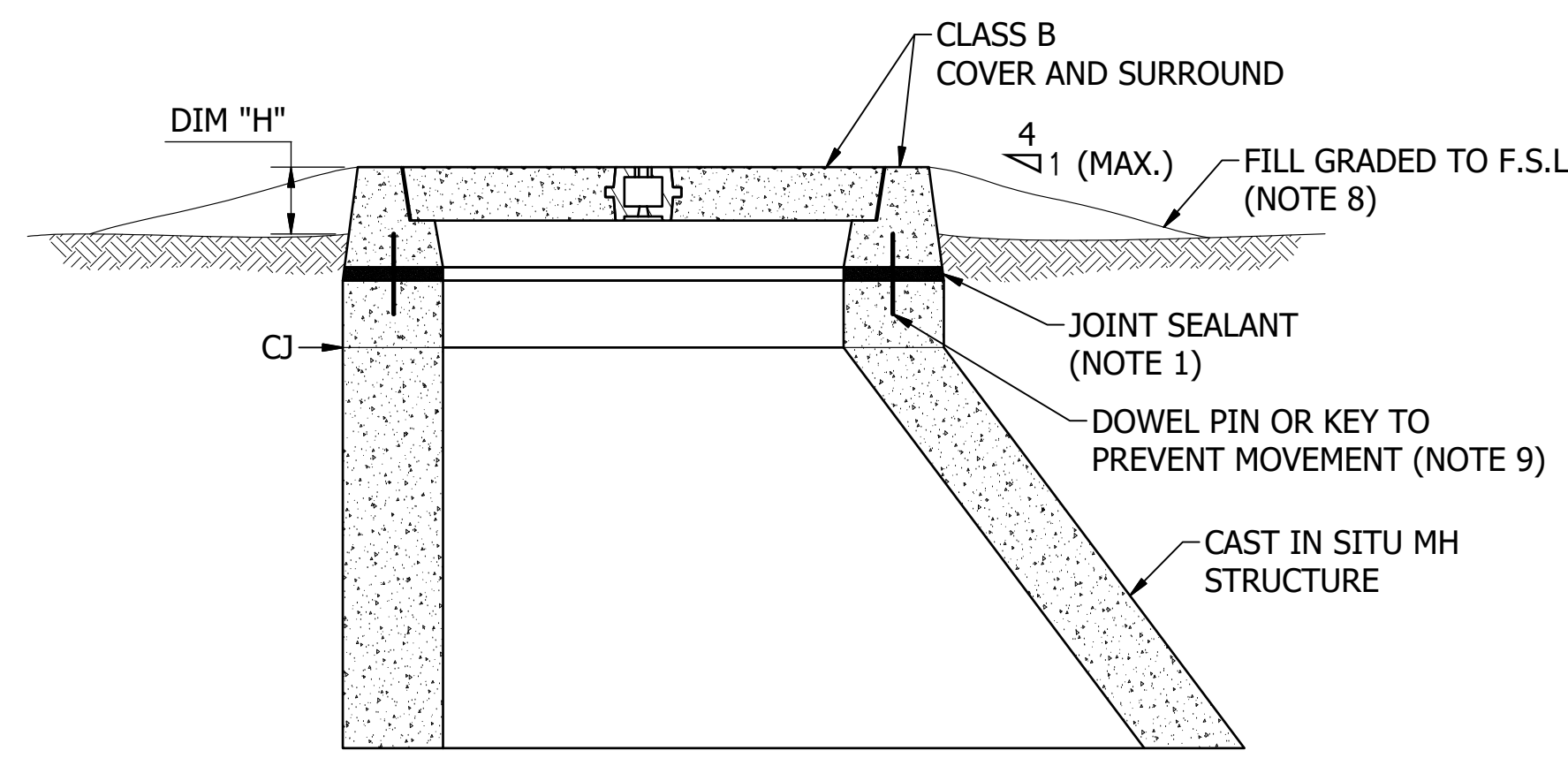

**CAST IN SITU MAINTENANCE HOLE
NON-TRAFFICABLE AREA**
SCALE: 1 : 10

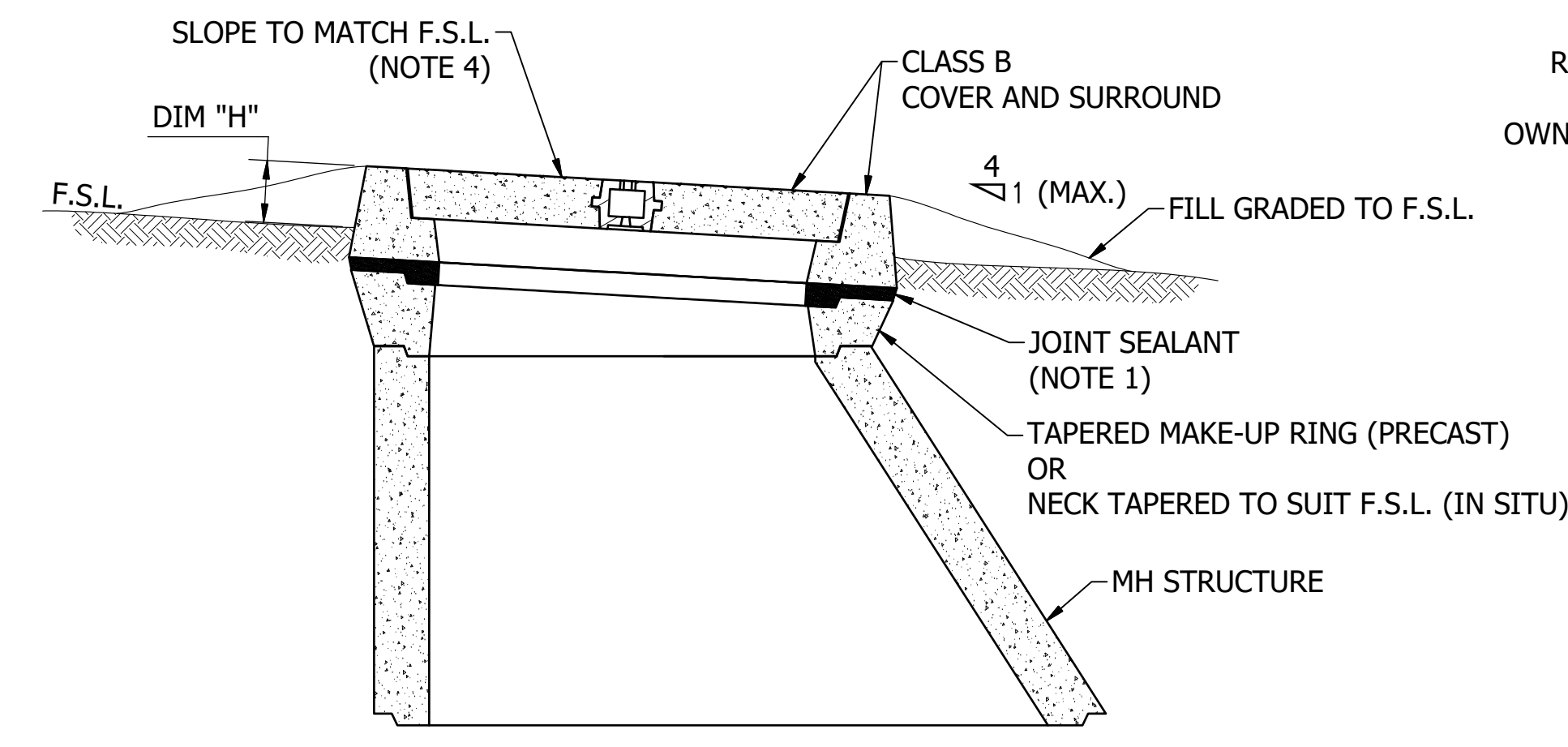

**PRECAST AND CAST IN SITU
MAINTENANCE HOLE (PRECAST SHOWN)
NON-TRAFFICABLE AREA
(SLOPING GROUND)**
SCALE: 1 : 10

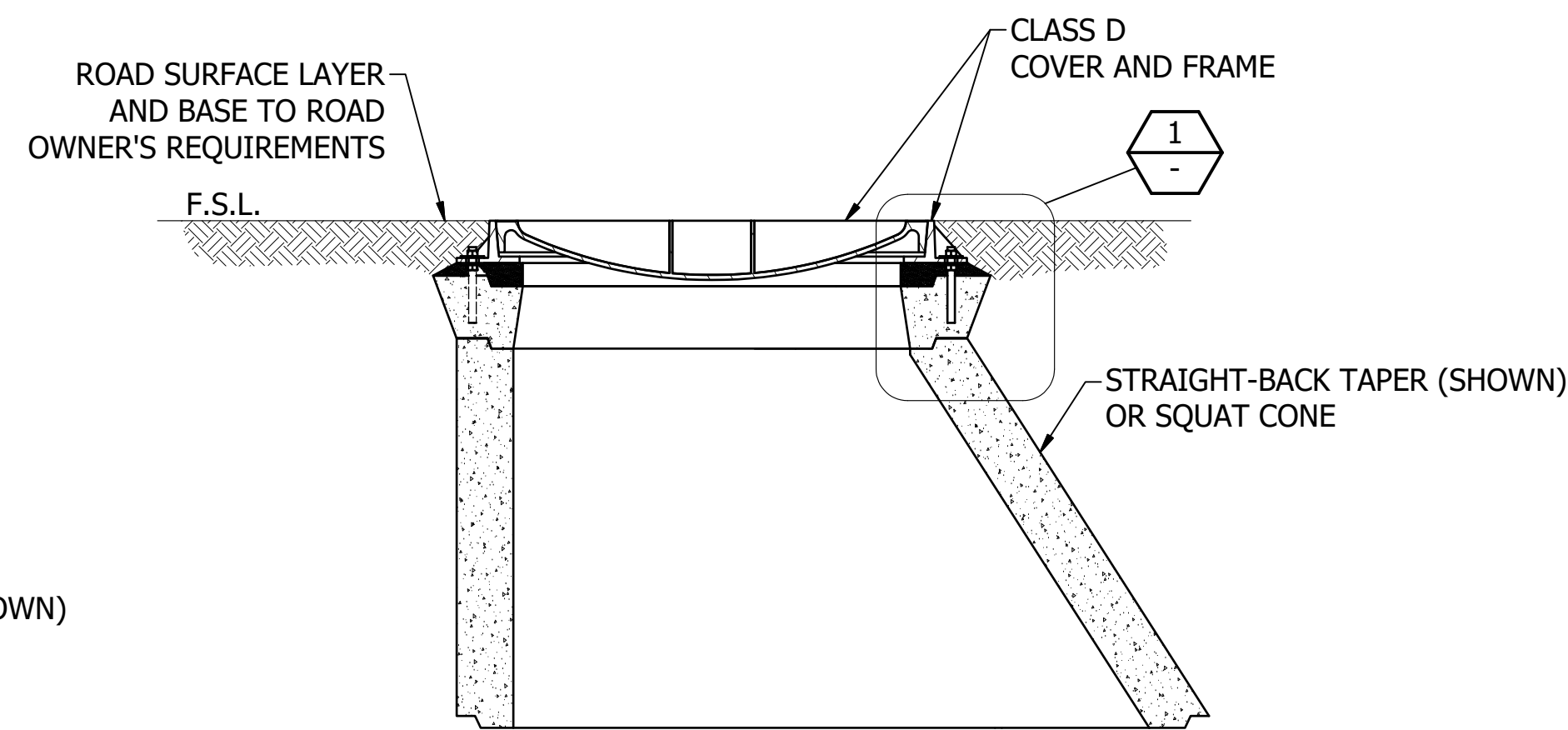

**PRECAST MAINTENANCE HOLE
TRAFFICABLE AREA**
SCALE: 1 : 10

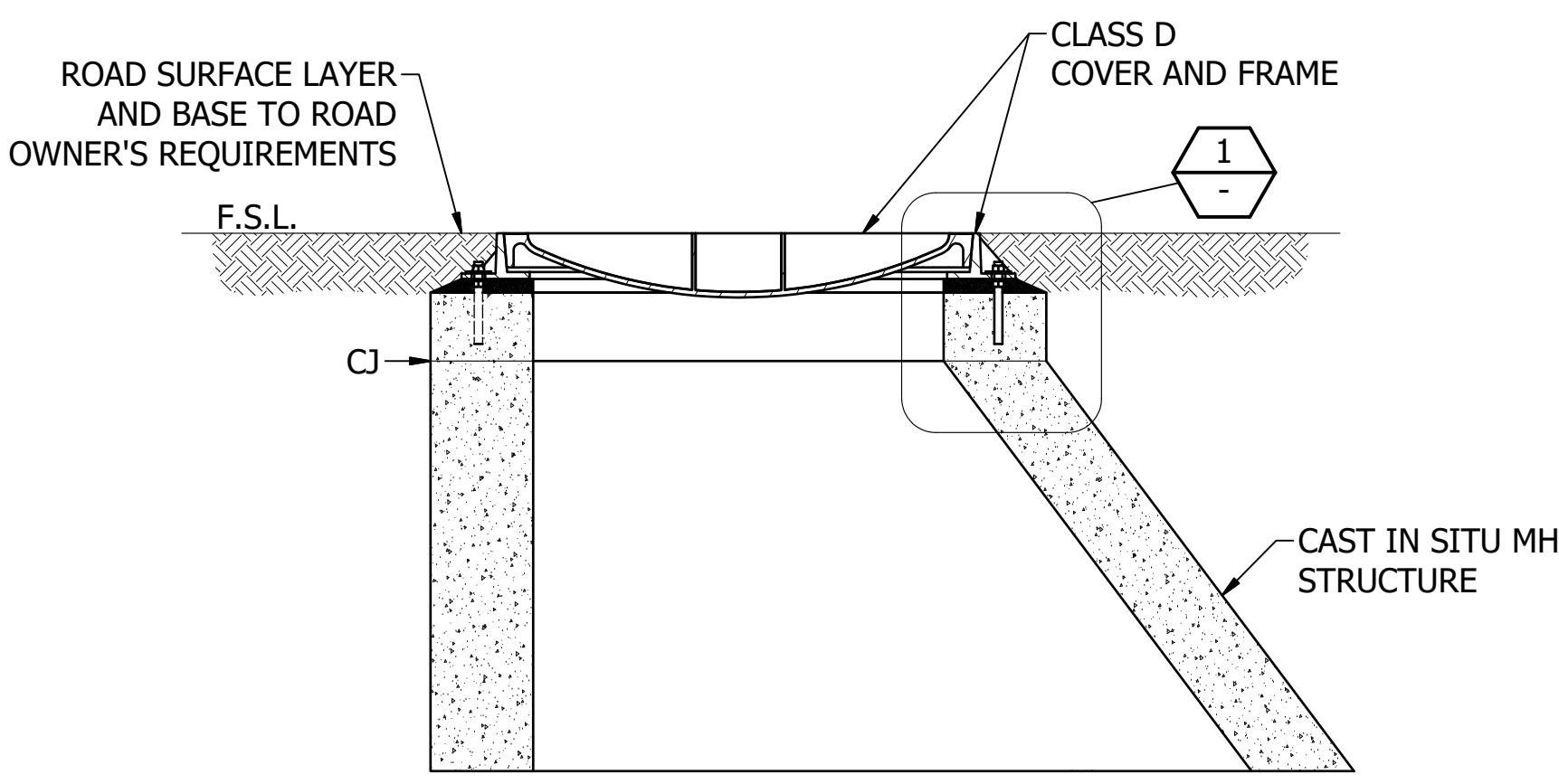

**CAST IN SITU MAINTENANCE HOLE
TRAFFICABLE AREA**
SCALE: 1 : 10

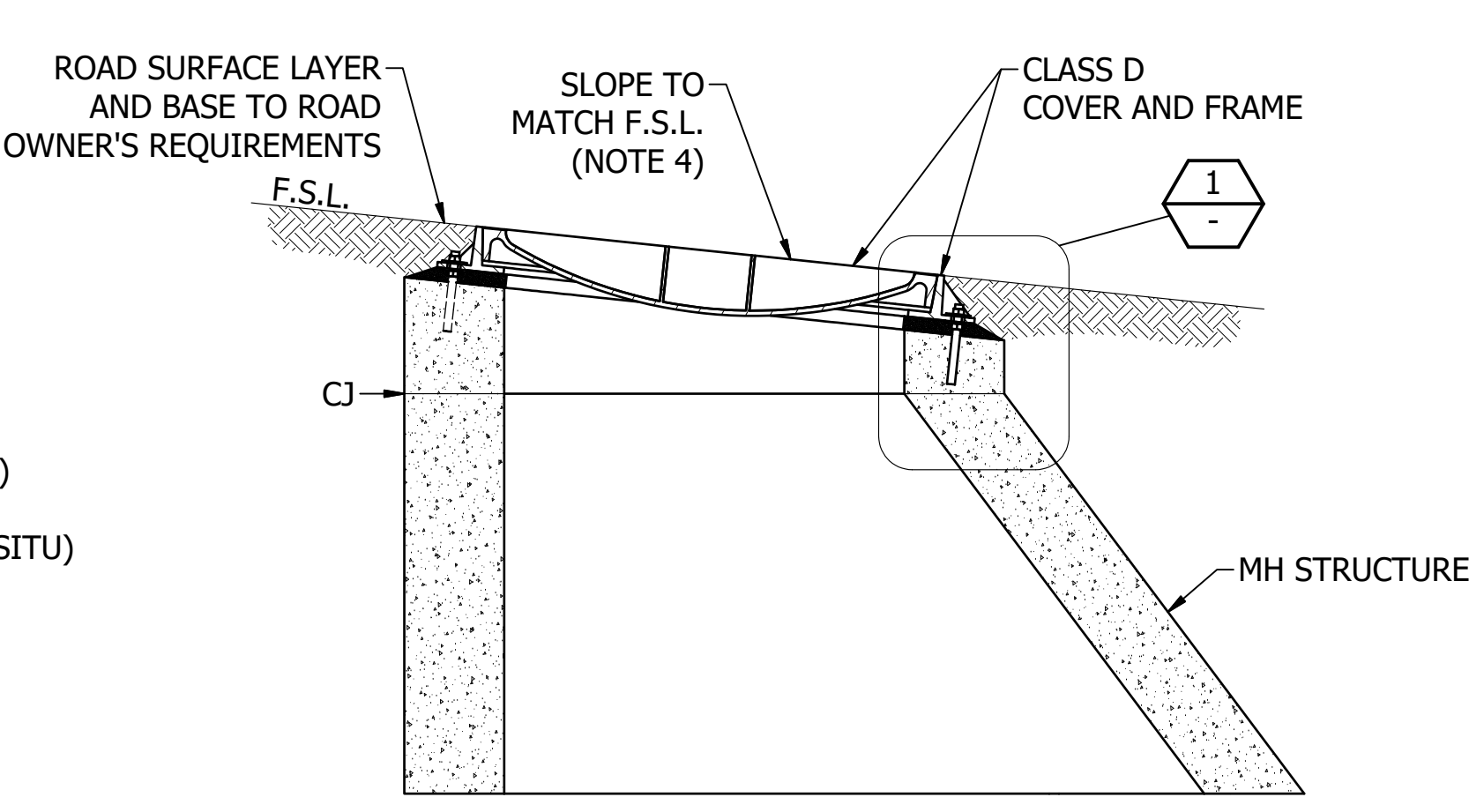

**PRECAST AND CAST IN SITU
MAINTENANCE HOLE (CAST IN SITU SHOWN)
TRAFFICABLE AREA
(SLOPING GROUND)**
SCALE: 1 : 10

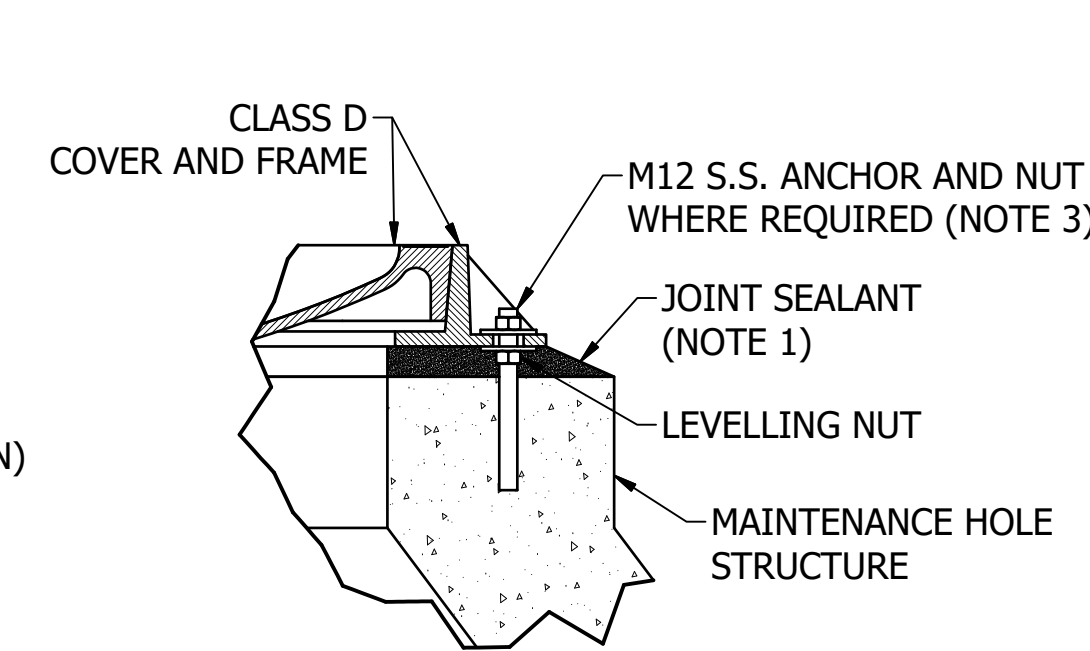

**CLASS D COVER AND FRAME
ANCHORING**
SCALE: 1 : 5

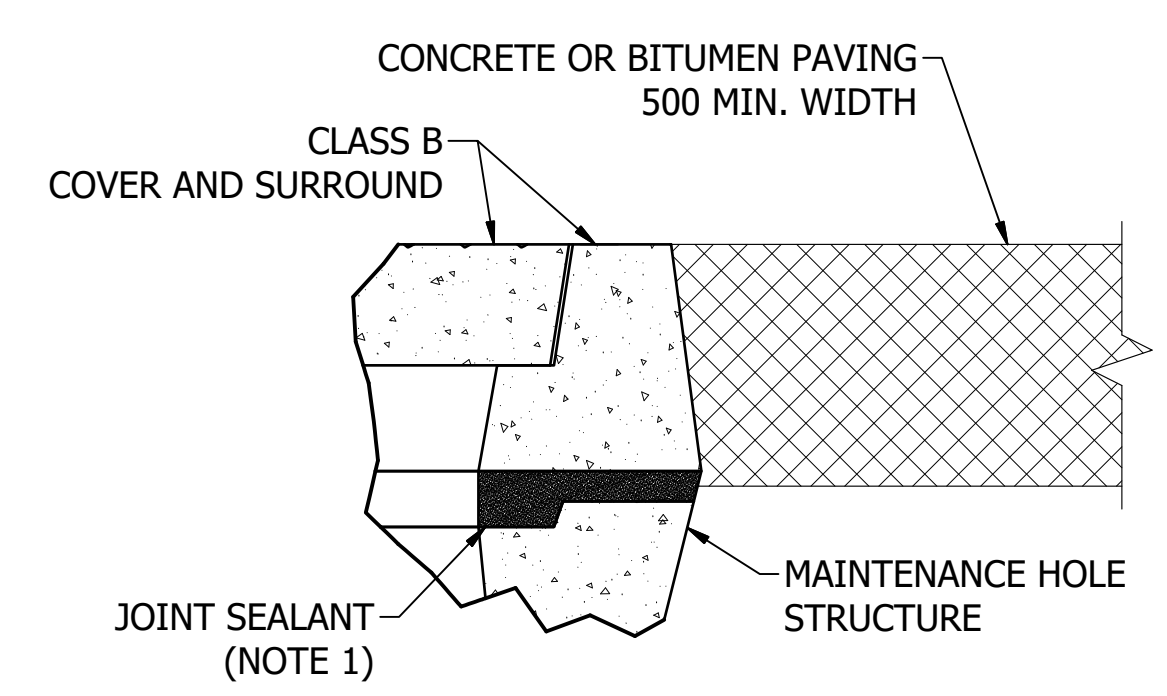

**CLASS B COVER AND SURROUND
IN PAVED (NON-TRAFFICABLE) AREAS**
SCALE: 1 : 5

NOTES:

- SEALING METHODS:
 - MAKE JOINTS BETWEEN SHAFT TOP/MAKEUP RING AND COVER SUPPORT RING USING:
 - POLYURETHANE SEALANT.
 - CEMENT MORTAR PAD MADE FROM 3 PARTS SAND TO 1 PART CEMENT.
 - APPLY POLYURETHANE SEALANT IN ACCORDANCE WITH THE MANUFACTURER'S SPECIFICATIONS, MAX THICKNESS 10.
 - THICKNESS OF CEMENT MORTAR AT ANY JOINT TO BE NO GREATER THAN 50.
 - SCABBLE AND CLEAN JOINT SURFACES SO THAT ALL LOOSE OR SOFT MATERIAL IS REMOVED.
 - JOINT SURFACES TO BE BRUSHED CLEAN, SPONGED WET AND PRIMED WITH CEMENT/WATER SLURRY PRIOR TO PLACING THE CEMENT MORTAR.
- IN AREAS SUBJECT TO SURCHARGE, USE CAST IN SITU MH. DOWEL OR BOLT COVER SLABS, DI COVER AND FRAME TO THE SHAFT SECTION IN SUCH A MANNER THAT SEPARATION DURING SURCHARGE IS PREVENTED.
- WHERE SPECIFIED, JOIN METAL FRAME TO CAST IN SITU MH RISER AS FOLLOWS:
 - MAKE JOINT BETWEEN SHAFT TOP AND METAL FRAME USING POLYURETHANE SEALANT AND LOCKING DOWN BOLTS EQUALLY PLACED AROUND THE CIRCUMFERENCE. USE 4 x M12 H.D.G OR STAINLESS STEEL BOLTS AND NUTS EXTENDING 75 MIN. INTO CONCRETE. FOR NON-TRAFFICABLE LOCATIONS USE A MINIMUM OF 2 BOLTS; FOR TRAFFICABLE LOCATIONS USE A MINIMUM OF 4 BOLTS.
- MAXIMUM PERMISSIBLE SLOPE OF COVERS:
 - CLASS B = 1 IN 7
 - CLASS D = 1 IN 10
- ALL COVERS TO BE WATER TIGHT. WHERE SPECIFIED USE GAS-TIGHT COVERS.
- DUE TO INCREASED INJURY RATES ASSOCIATED WITH HAZARDOUS MANUAL TASKS, METAL COVERS WITH CONCRETE (OR TILED) INFILL SHALL NOT BE USED WITHOUT SPECIAL APPROVAL BY ICON WATER.
- CLASS B REINFORCED PLASTIC COVERS MAY BE USED TO REPLACE EXISTING CLASS B COVERS IN AREAS NOT PRONE TO BUSHFIRE. SUCH COVERS SHALL NOT BE USED FOR NEW DEVELOPMENT AND SHALL ONLY BE INSTALLED BY ICON WATER PERSONNEL.
- DETAIL 2 IS TO BE USED WHERE INDICATED IN THE TABLE BELOW.
- A BONDED CONCRETE RING KEYED TO PREVENT MOVEMENT IN CONJUNCTION WITH A MORTAR PAD, COVER AND SURROUND IS AN APPROVED ALTERNATIVE TO THE DETAIL SHOWN FOR COMMERCIAL MOWED OPEN SPACES.

LOCATION	MH COVER REQUIREMENTS	DIM "H" (mm)
TRAFFICABLE PAVED AREAS INCLUDING PUBLIC AND PRIVATE ROADS AS WELL AS RESIDENTIAL AND COMMERCIAL DRIVEWAYS.	CLASS D METAL COVER AND METAL SURROUND. BOLT DOWN IN ACCORDANCE WITH NOTE 3 WHEN THE LOCATION IS SUBJECT TO SURCHARGE (e.g. AN OVERLOADED SEWER OR WITHIN 100 METRES OF A SEWER RISING MAIN) OR IN A 1:100 ARI FLOOD EVENT ZONE.	IN BASEMENTS AND PAVED AREAS: H = 0
NON-PAVED AREAS WHICH HAVE A HIGH LIKELIHOOD OF VEHICLE TRAFFIC.		IN EXISTING AND BUILT-UP AREAS: H = 25
PAVED OR NON-PAVED AREAS NOT SUBJECT TO VEHICLE TRAFFIC OR SURCHARGE OR FLOOD WITH NO REQUIREMENT TO BE GAS-TIGHT.	CLASS B REINFORCED CONCRETE COVER AND SURROUND OR CLASS B METAL COVER AND METAL (OR CONCRETE) SURROUND. REFER TO DETAIL 2 FOR PAVED AREAS.	IN NEW SUBDIVISIONS: H = 75
BASEMENTS AND OTHER POORLY VENTILATED AREAS	CLASS B OR CLASS D METAL COVER AND SURROUND AS APPLICABLE DEPENDING UPON WHETHER LOCATION IS NON-TRAFFICABLE OR TRAFFICABLE RESPECTIVELY. GAS-TIGHT AND BOLT DOWN IN ACCORDANCE WITH NOTE 3.	IN UNDEVELOPED AREAS: H = 100
SEWAGE PUMPING STATIONS - COLLECTION MAINTENANCE HOLES		IN FLOOD PRONE AREAS: H = 150 MIN

No.	ISSUE	DATE	DRAWN	CHECKED	AUTHORISED
A	INITIAL ISSUE	15/06/2018	M. Matusiak	K. Danenbergs	D. Eager
B	DRAWING AND NOTES UPDATED. DRAWING NOW -D	18/06/2019	S. Essery	K. Danenbergs	C. Patrick
C	DETAIL 2, NOTES 8 & 9 ADDED	17/07/2019	S. Essery	K. Danenbergs	C. Patrick

ICON WATER ACKNOWLEDGES WATER SERVICES ASSOCIATION OF AUSTRALIA IN THE DEVELOPMENT OF THIS DRAWING. IN PARTICULAR, DRAWING SEW-1308

ASSET AREA APPLICABILITY			
DAM	RES	SPS	X
BWS	WAT	STP	X
WTP	SEW		X
WPS	REC		



STANDARD DRAWING
SEWERAGE NETWORK
PRECAST AND CAST IN SITU MAINTENANCE HOLES
1050, 1200 AND 1500 DIA. COVERS AND SURROUNDS
ARRANGEMENT AND FIXING DETAILS

DRAWING STATUS	Current
	SD-2204-D
A1	© Icon Water 2017

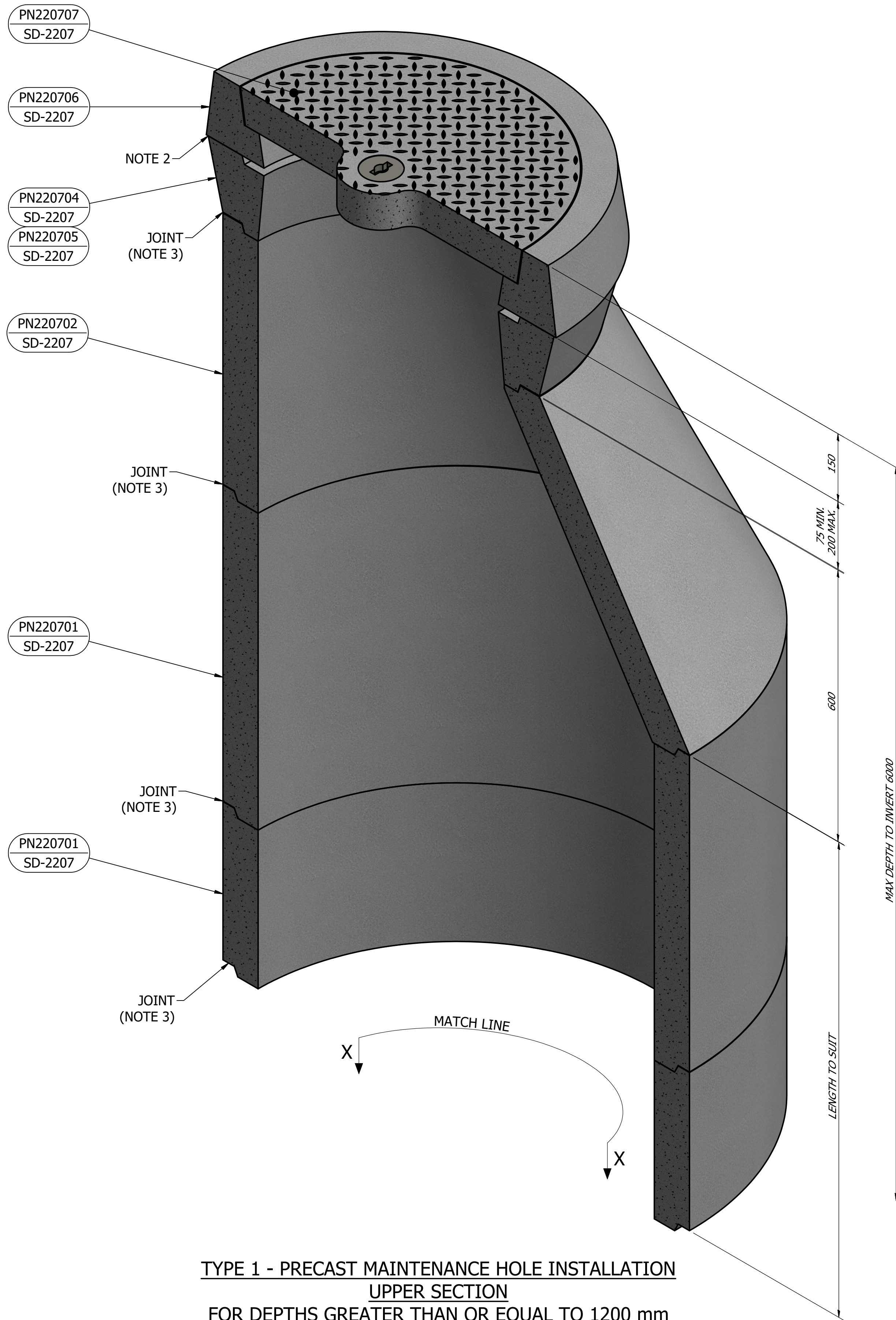

TYPE 1 - PRECAST MAINTENANCE HOLE INSTALLATION
UPPER SECTION
FOR DEPTHS GREATER THAN OR EQUAL TO 1200 mm
 (STEP IRONS NOT SHOWN)
 SCALE: 1 : 5

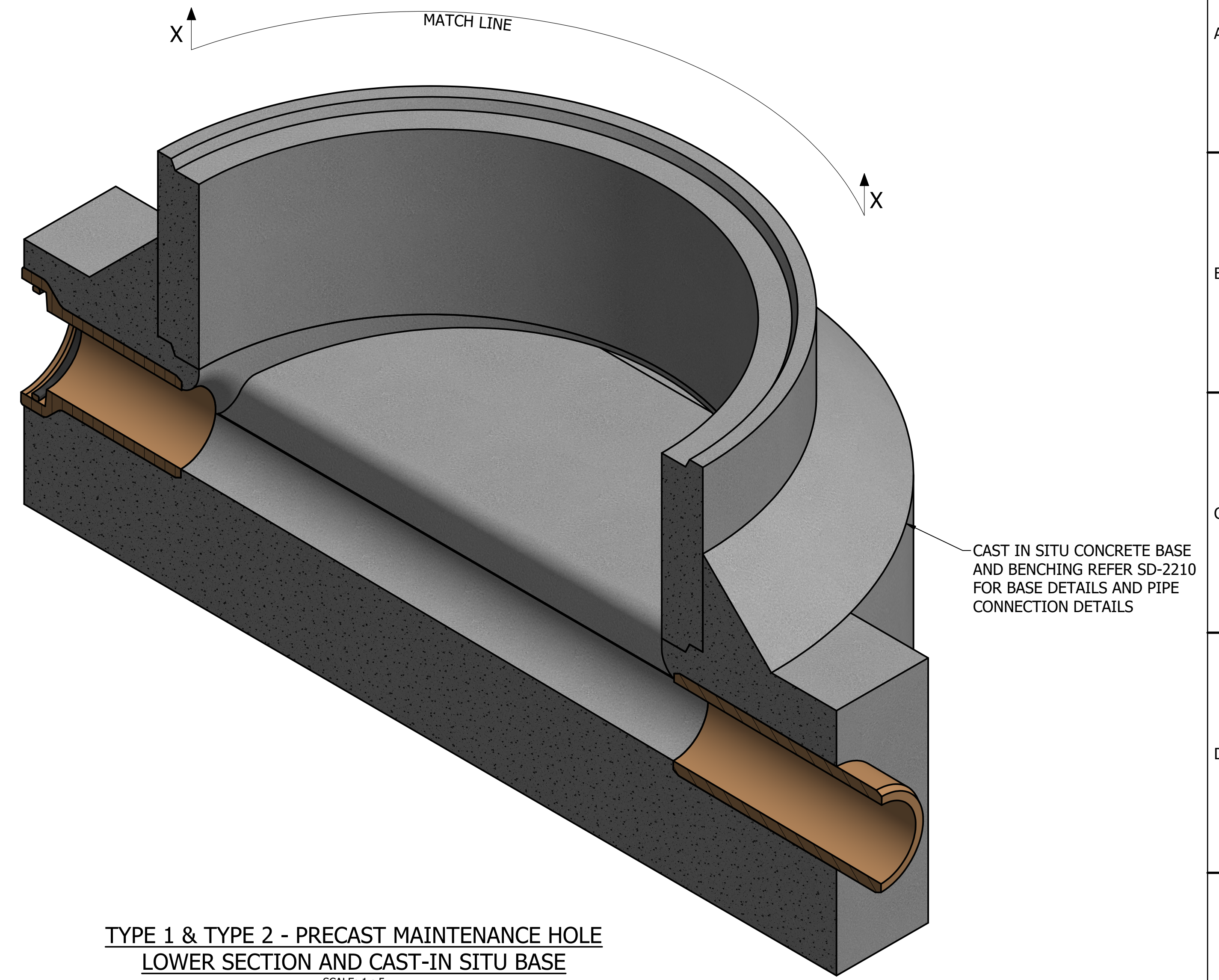

TYPE 1 & TYPE 2 - PRECAST MAINTENANCE HOLE
LOWER SECTION AND CAST-IN SITU BASE
 SCALE: 1 : 5

PARTS LIST		
PART NUMBER	DESCRIPTION	REFERENCE
PN220701	SHAFT SECTION	SD-2207
PN220702	STRAIGHT BACK TAPER	SD-2207
PN220704	MAKEUP RING	SD-2207
PN220705	TAPERED MAKEUP RING	SD-2207
PN220706	COVER FRAME (CLASS B)	SD-2207
PN220707	REMOVABLE COVER (CLASS B)	SD-2207

NOTES:

- FOR MAINTENANCE HOLE COMPONENTS REFER TO SD-2207 FOR DETAILS.
- FOR COVER FRAME FIXING DETAILS REFER TO SD-2204.
- ALL JOINTS BETWEEN MAINTENANCE HOLE SEGMENTS ARE TO BE RUBBER RING, MASTIC OR EPOXY. USE APPROPRIATE JOINT TYPE BASED ON SOIL TYPE AND RESTRICTION OF WATER INGRESS REQUIREMENTS.
- REFER TO THE ICON WATER APPROVED PRODUCTS LIST FOR APPROVED MANUFACTURERS.

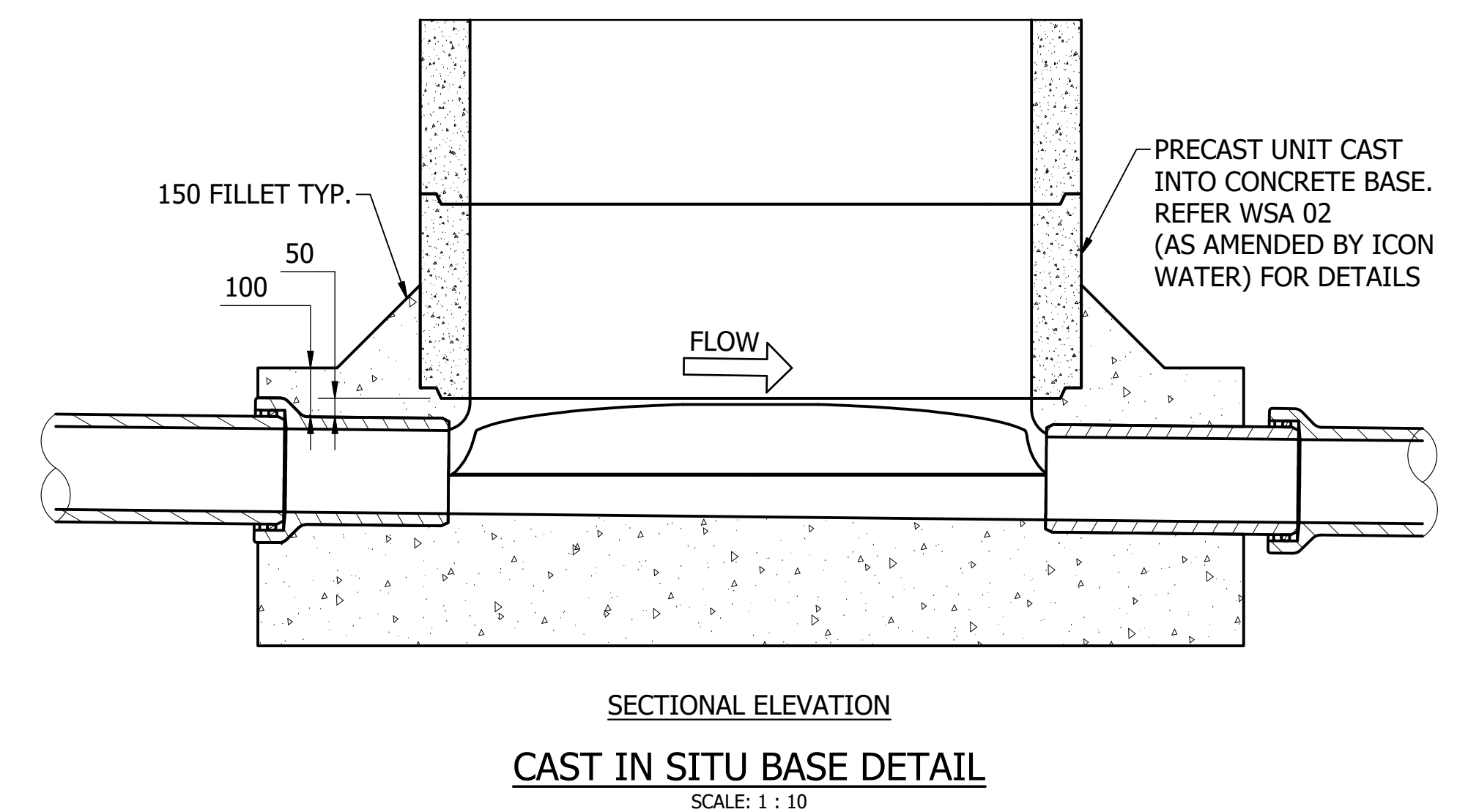

SECTIONAL ELEVATION
CAST IN SITU BASE DETAIL
 SCALE: 1 : 10

No.	ISSUE	DATE	DRAWN	CHECKED	AUTHORISED
A	INITIAL ISSUE	15/06/2018	M. Matusiak	K. Danenbergson	D. Eager
B	MODEL CORRECTION. DRAWING NOW -D	19/06/2019	S. Essery	K. Danenbergson	C. Patrick

ASSET AREA APPLICABILITY				
DAM	RES	SPS	X	
BWS	WAT	STP	X	
WTP	SEW		X	
WPS	REC			



STANDARD DRAWING
 SEWERAGE NETWORK
 PRECAST MAINTENANCE HOLES
 FOR DEPTHS LESS THAN 6000 mm
 TYPICAL ARRANGEMENT AND BASE DETAILS

DRAWING STATUS	
Current	
SD-2205-D	
A1	ISSUE B
© Icon Water 2017	

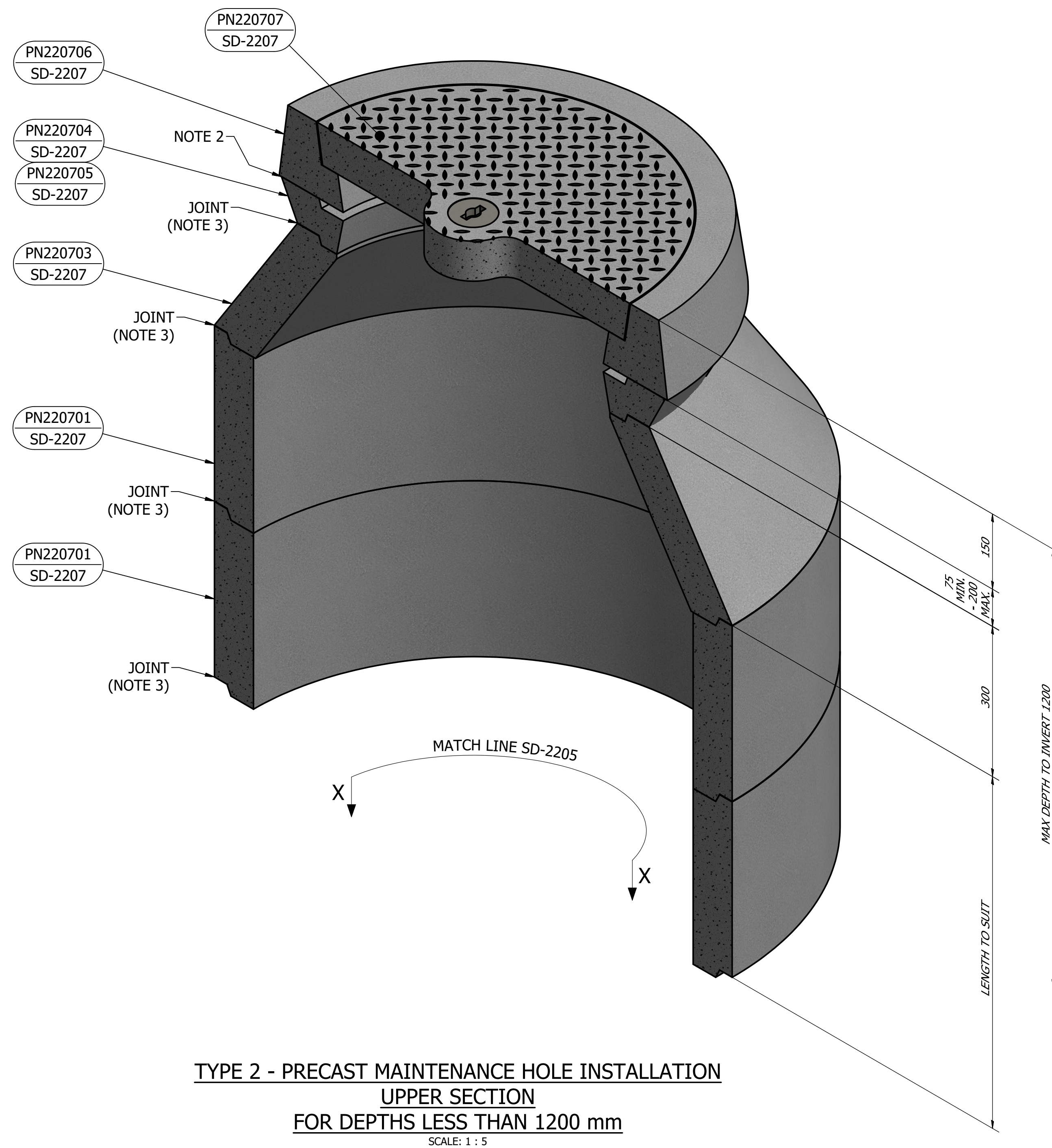

**TYPE 2 - PRECAST MAINTENANCE HOLE INSTALLATION
UPPER SECTION
FOR DEPTHS LESS THAN 1200 mm**
SCALE: 1 : 5

PARTS LIST		
PART NUMBER	DESCRIPTION	REFERENCE
PN220701	SHAFT SECTION	SD-2207
PN220703	SQUAT CONE	SD-2207
PN220704	MAKEUP RING	SD-2207
PN220705	TAPERED MAKEUP RING	SD-2207
PN220706	COVER FRAME (CLASS B)	SD-2207
PN220707	REMOVABLE COVER (CLASS B)	SD-2207

NOTES:

- FOR MAINTENANCE HOLE COMPONENTS REFER TO SD-2207 FOR DETAILS.
- FOR COVER FRAME FIXING DETAILS REFER TO SD-2204.
- ALL JOINTS BETWEEN MAINTENANCE HOLE SEGMENTS ARE TO BE RUBBER RING, MASTIC OR EPOXY. USE APPROPRIATE JOINT TYPE BASED ON SOIL TYPE AND RESTRICTION OF WATER INGRESS REQUIREMENTS.
- REFER TO THE ICON WATER APPROVED PRODUCTS LIST FOR APPROVED MANUFACTURERS.

No.	ISSUE	DATE	DRAWN	CHECKED	AUTHORISED
A	INITIAL ISSUE	15/06/2018	M. Matusiak	K. Danenbergsons	D. Eager
B	DRAWING CHANGED TO -D	18/06/2019	S. Essery	K. Danenbergsons	C. Patrick

ASSET AREA APPLICABILITY				
DAM	RES	SPS	WAT	STP
BWS	WAT	STP		
WTP	SEW			
WPS	REC			



STANDARD DRAWING
SEWERAGE NETWORK
PRECAST MAINTENANCE HOLES
FOR DEPTHS LESS THAN 1200 mm
TYPICAL ARRANGEMENT

DRAWING STATUS	
Current	
SD-2206-D	
A1	ISSUE B
© Icon Water 2017	

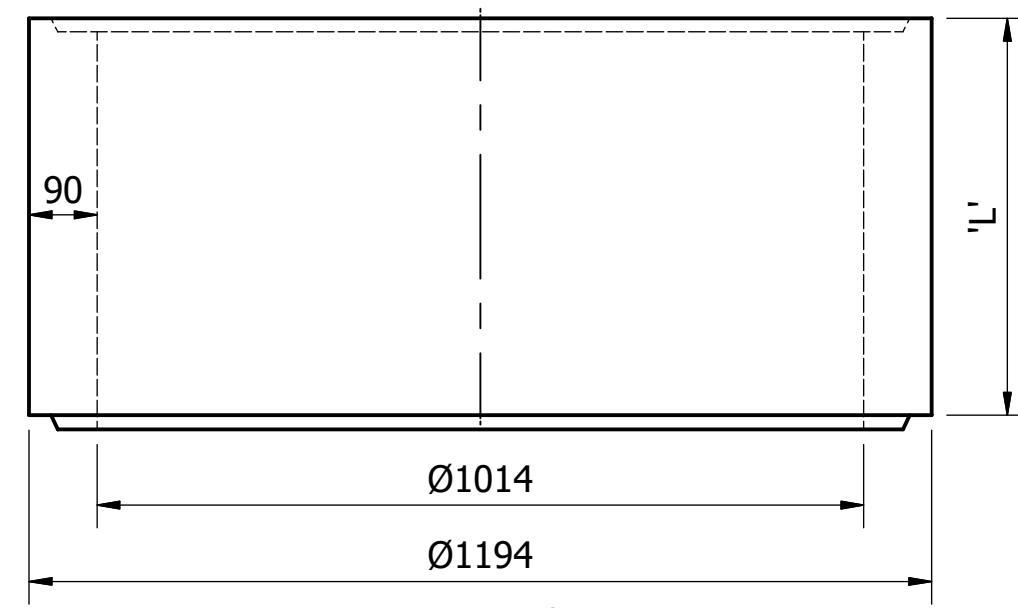

SHAFT SECTION
SCALE: 1 : 10

LENGTHS AND MASS
SCALE: N.T.S.

- L = 350 mm
APPROX. MASS: 260 kg
- L = 525 mm
APPROX. MASS: 390 kg
- L = 700 mm
APPROX. MASS: 520 kg
- L = 1050 mm
APPROX. MASS: 780 kg
- L = 1400 mm
APPROX. MASS: 1040 kg
- L = 2100 mm
APPROX. MASS: 1600 kg

ITEM	AMDT.
PN220701	

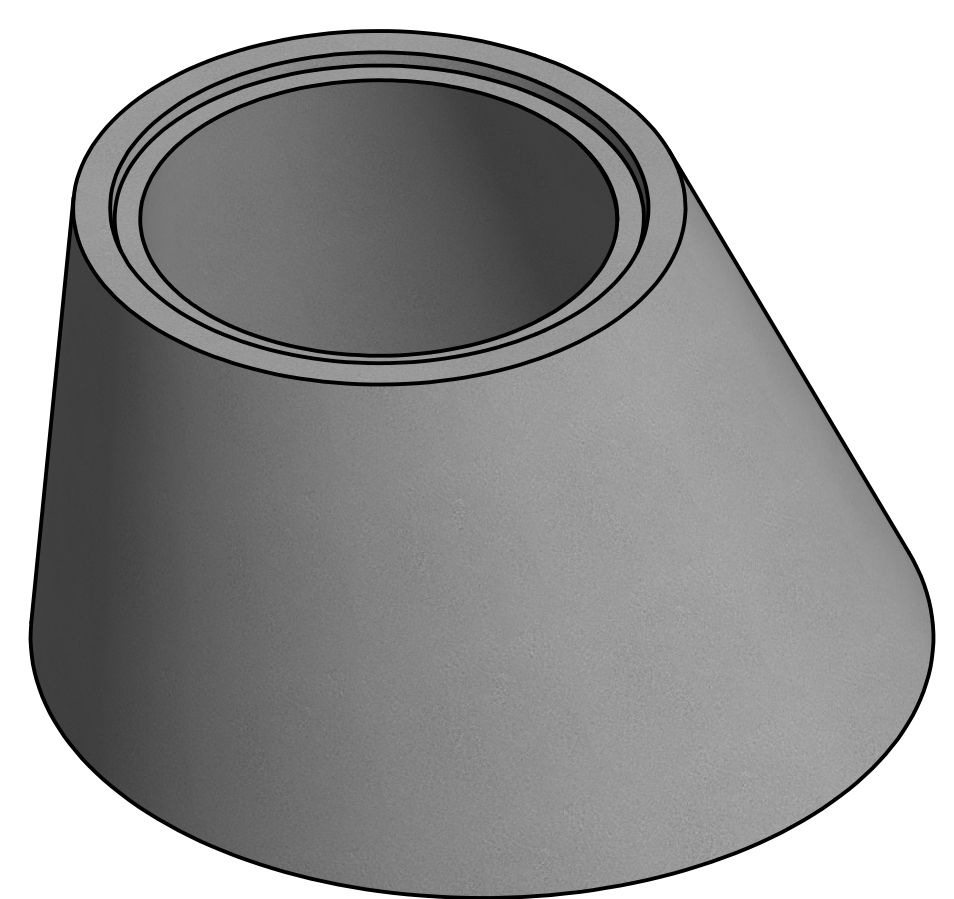

L = 600 mm
APPROX. MASS: 400 kg

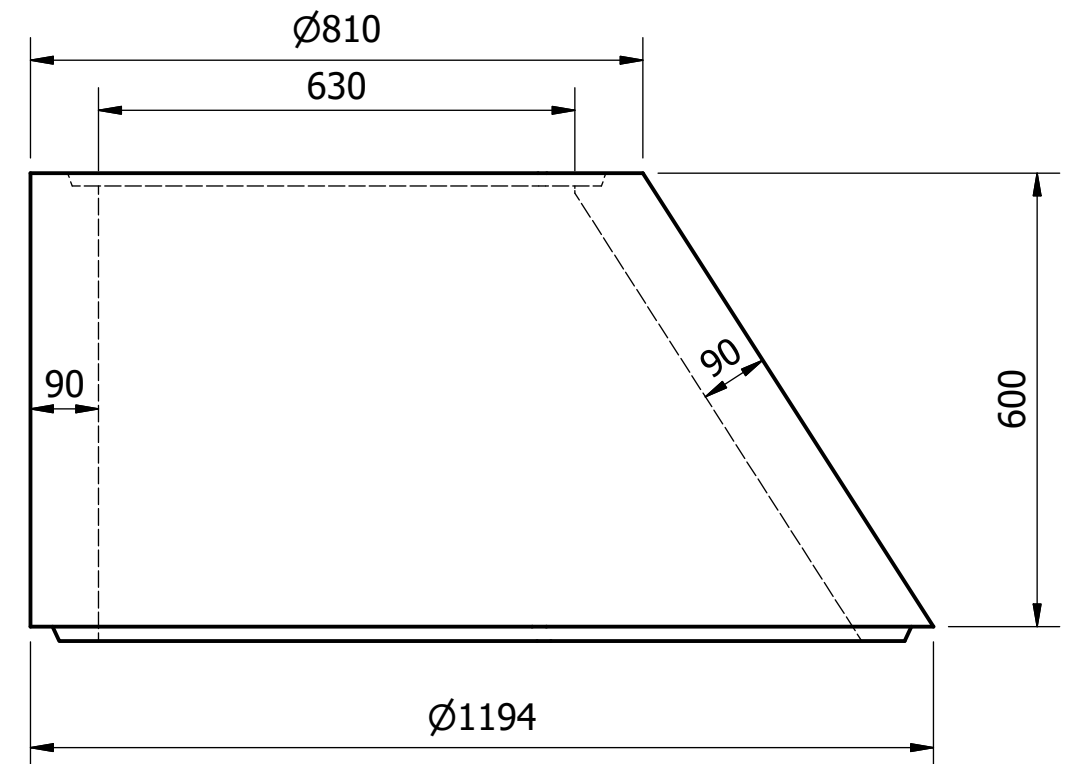

STRAIGHT BACK TAPER
SCALE: 1 : 10

ITEM	AMDT.
PN220702	



L = 300 mm
APPROX. MASS: 260 kg

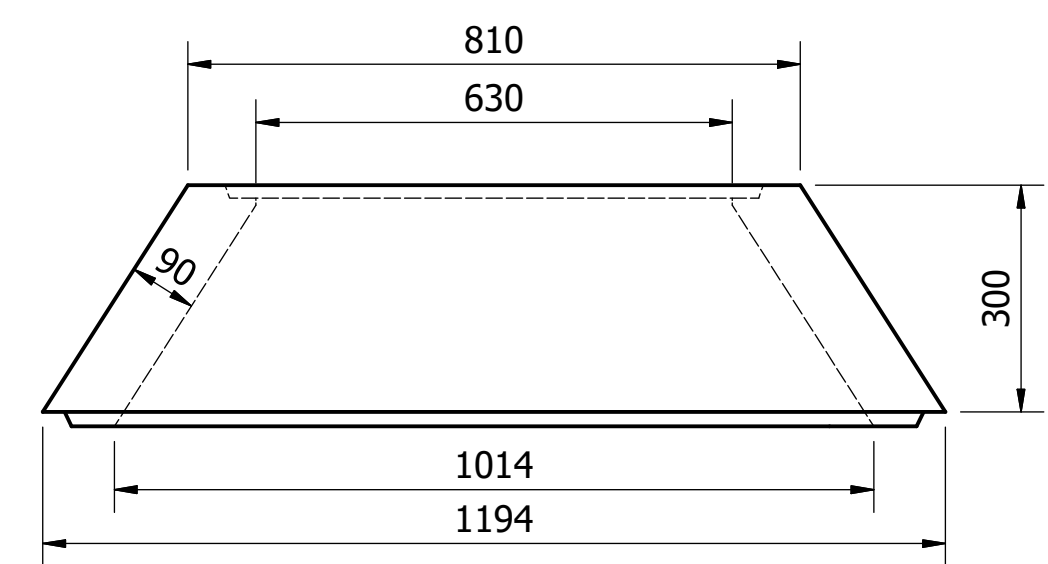

SQUAT CONE
SCALE: 1 : 10

ITEM	AMDT.
PN220703	

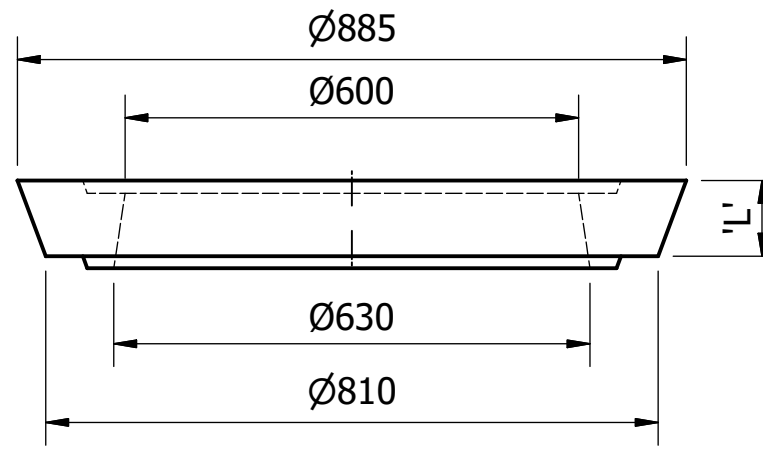

MAKE-UP RING
SCALE: 1 : 10

LENGTHS AND MASS
SCALE: N.T.S.

- L = 75 mm
APPROX. MASS: 50 kg
- L = 100 mm
APPROX. MASS: 65 kg
- L = 150 mm
APPROX. MASS: 100 kg
- L = 200 mm
APPROX. MASS: 130 kg

ITEM	AMDT.
PN220704	

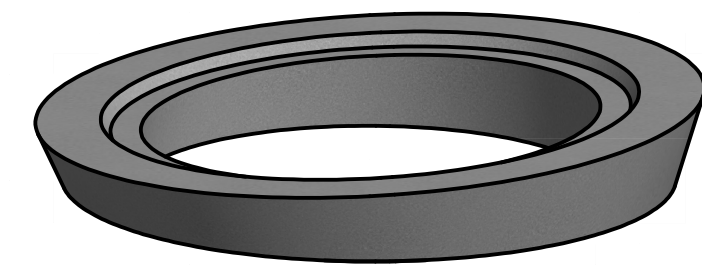

L = 75/125 mm
APPROX. MASS: 65 kg

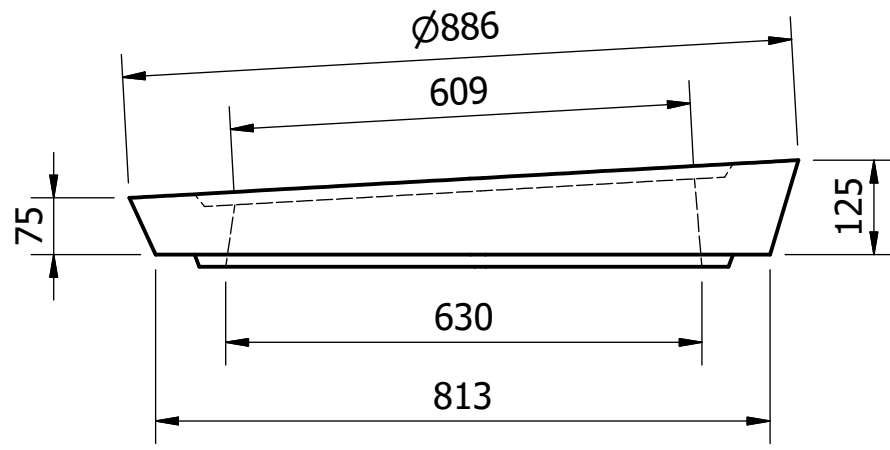

TAPERED MAKE-UP RING
SCALE: 1 : 10

ITEM	AMDT.
PN220705	

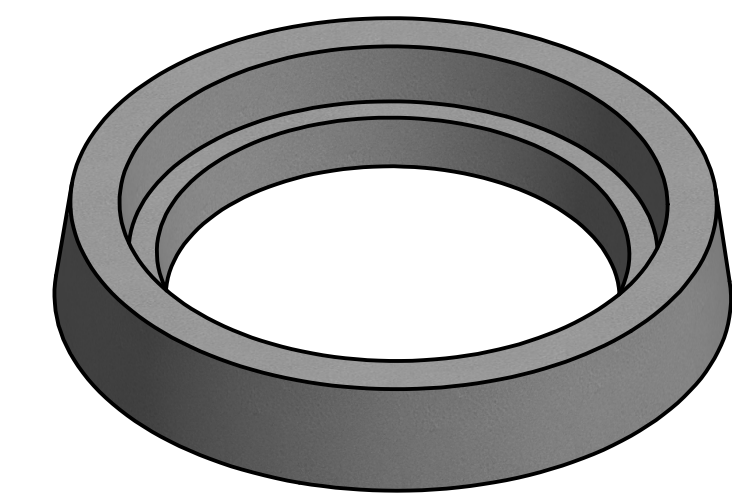

APPROX. MASS: 95 kg

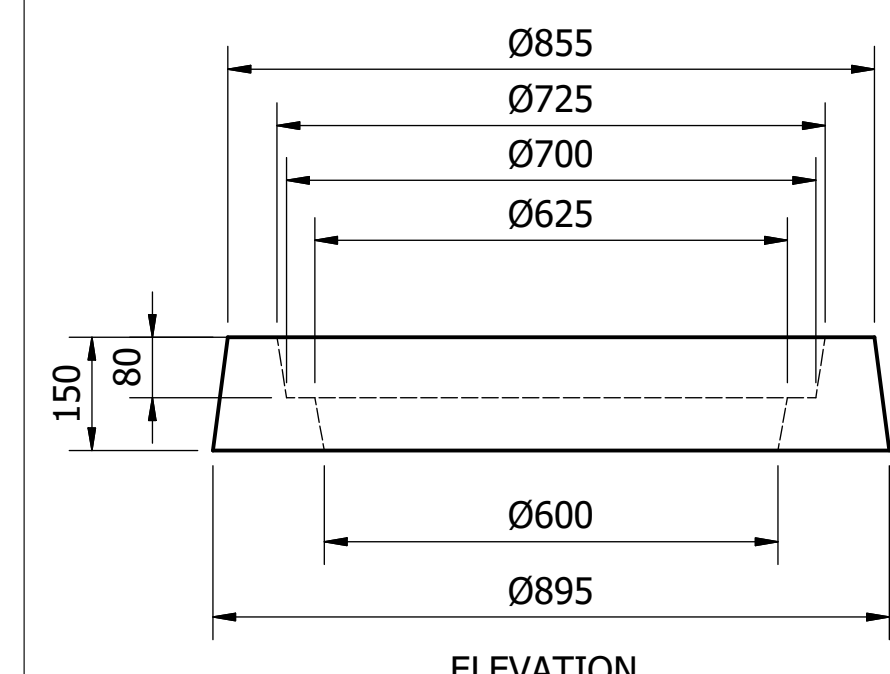

COVER FRAME - CLASS B
SCALE: 1 : 10

ITEM	AMDT.
PN220706	

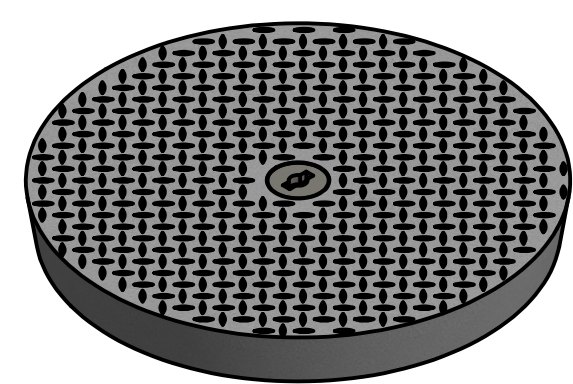

APPROX. MASS: 80 kg

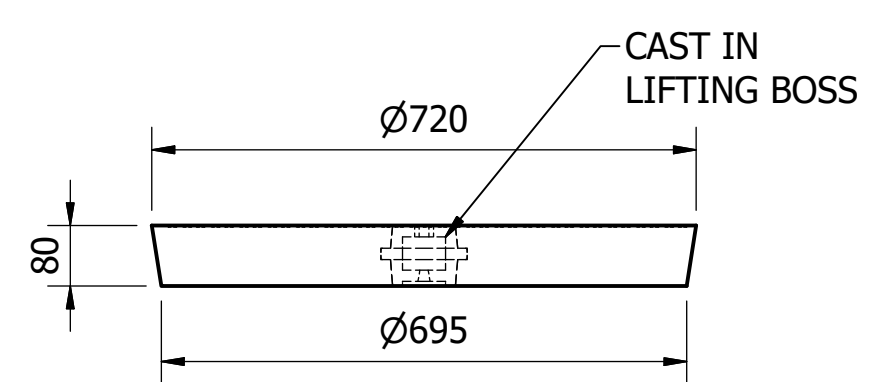

COVER - CLASS B
SCALE: 1 : 10

ITEM	AMDT.
PN220707	

DAM	RES	SPS
		X
BWS	WAT	STP
WTP	SEW	X
WPS	REC	



STANDARD DRAWING
SEWERAGE NETWORK
1050 DIA. PRECAST MAINTENANCE HOLES
TYPICAL COMPONENTS
DETAILS

DRAWING STATUS	
Current	
SD-2207-D	
A1	ISSUE B

© Icon Water 2017

No.	ISSUE	DATE	DRAWN	CHECKED	AUTHORISED
A	INITIAL ISSUE	15/06/2018	M. Matusiak	K. Danenbergsons	D. Eager
B	DRAWING CHANGED TO -D	18/06/2019	S. Essery	K. Danenbergsons	C. Patrick

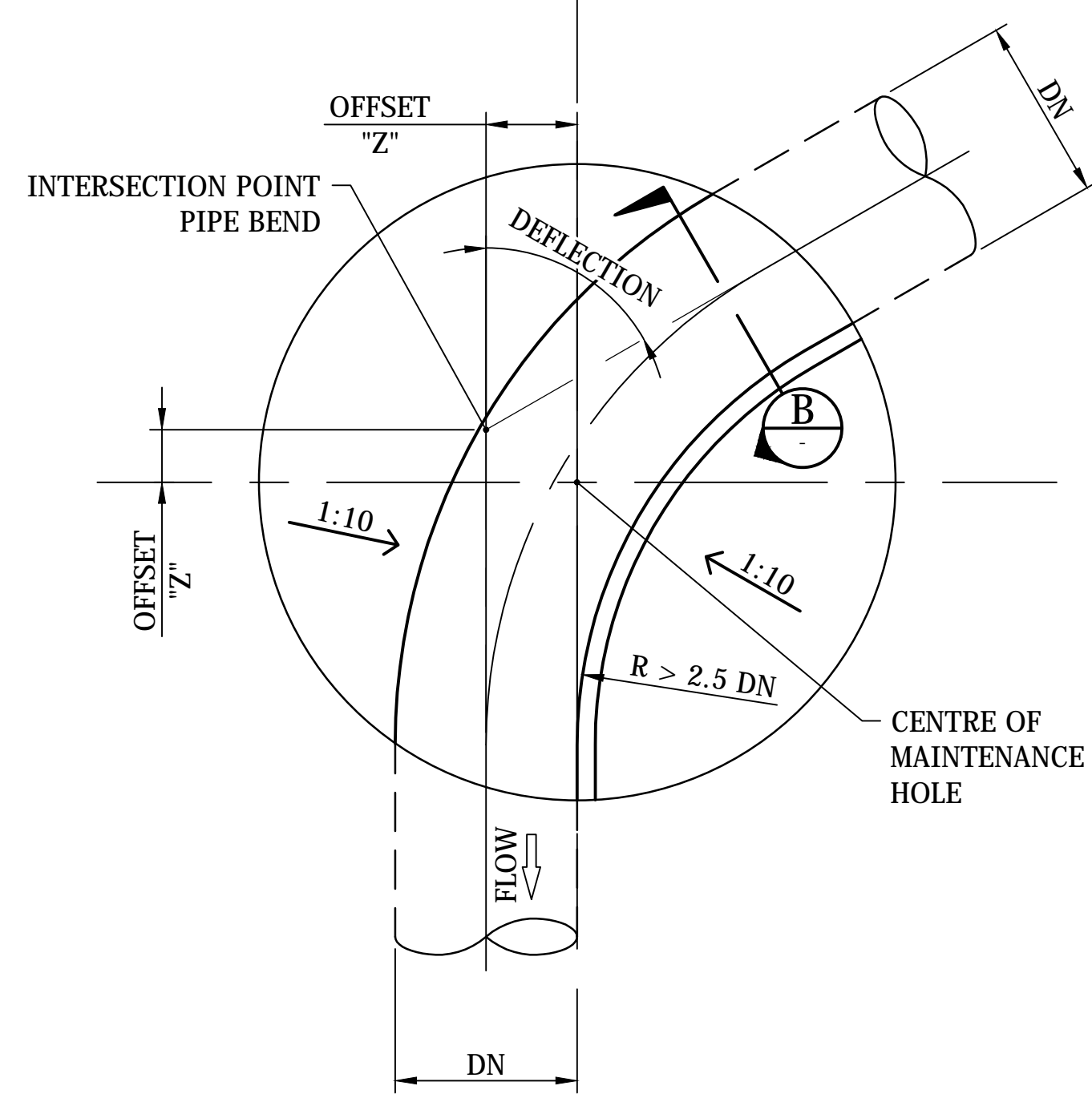

DEFLECTION THROUGH MAINTENANCE HOLE
SCALE 1:10

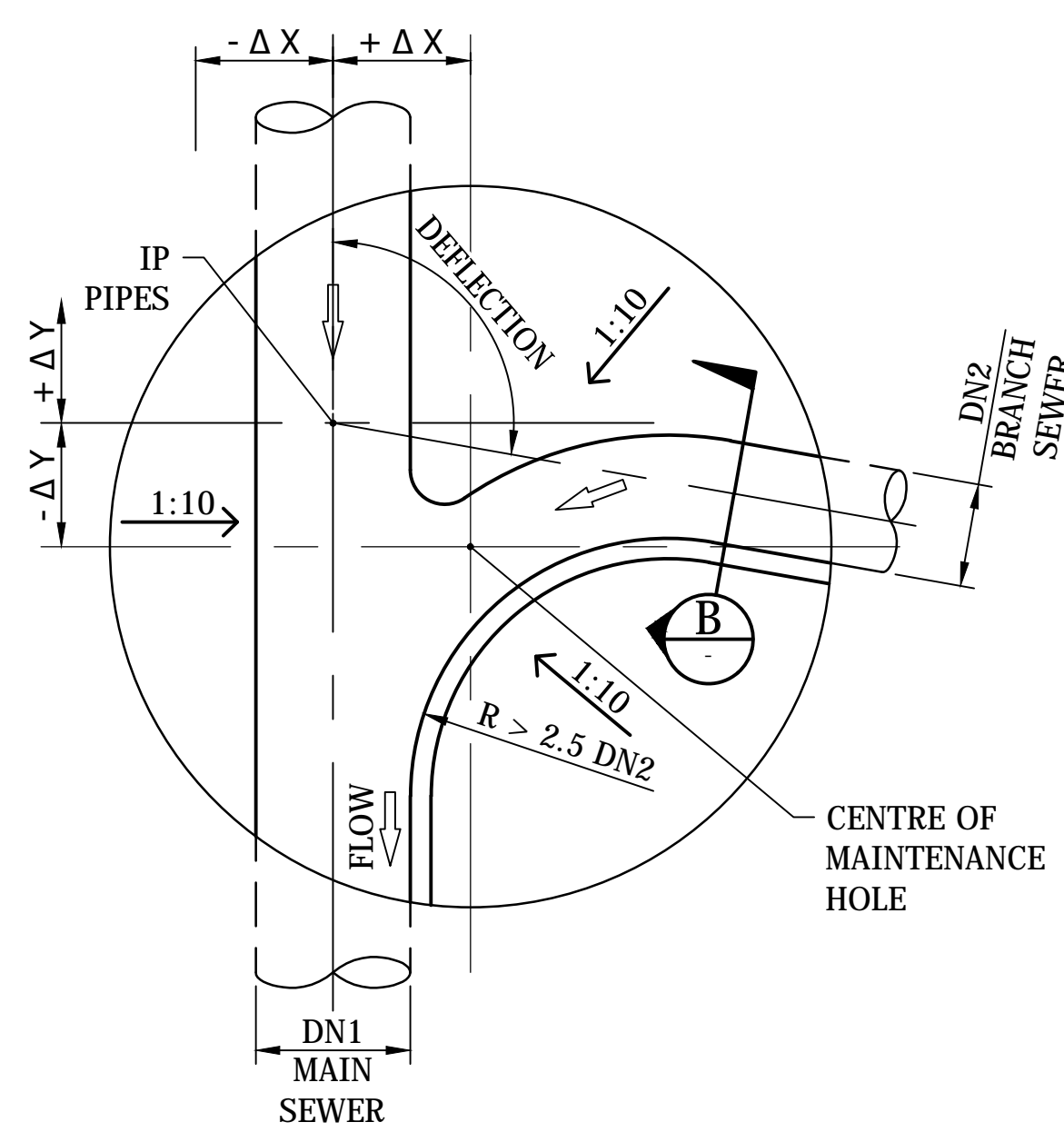

SINGLE BRANCH JUNCTION
SCALE 1:10

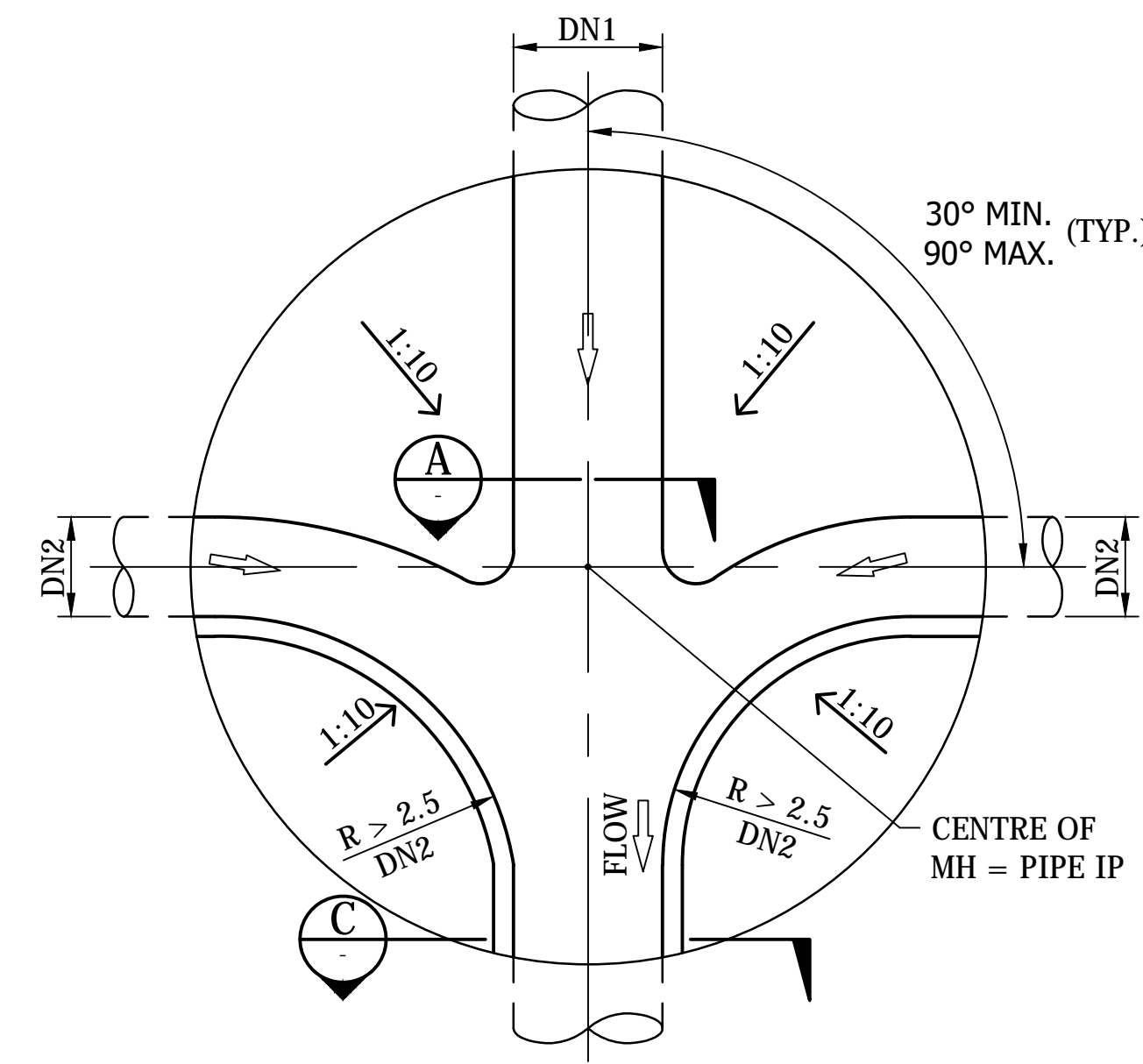

DOUBLE BRANCH JUNCTION
SCALE 1:10

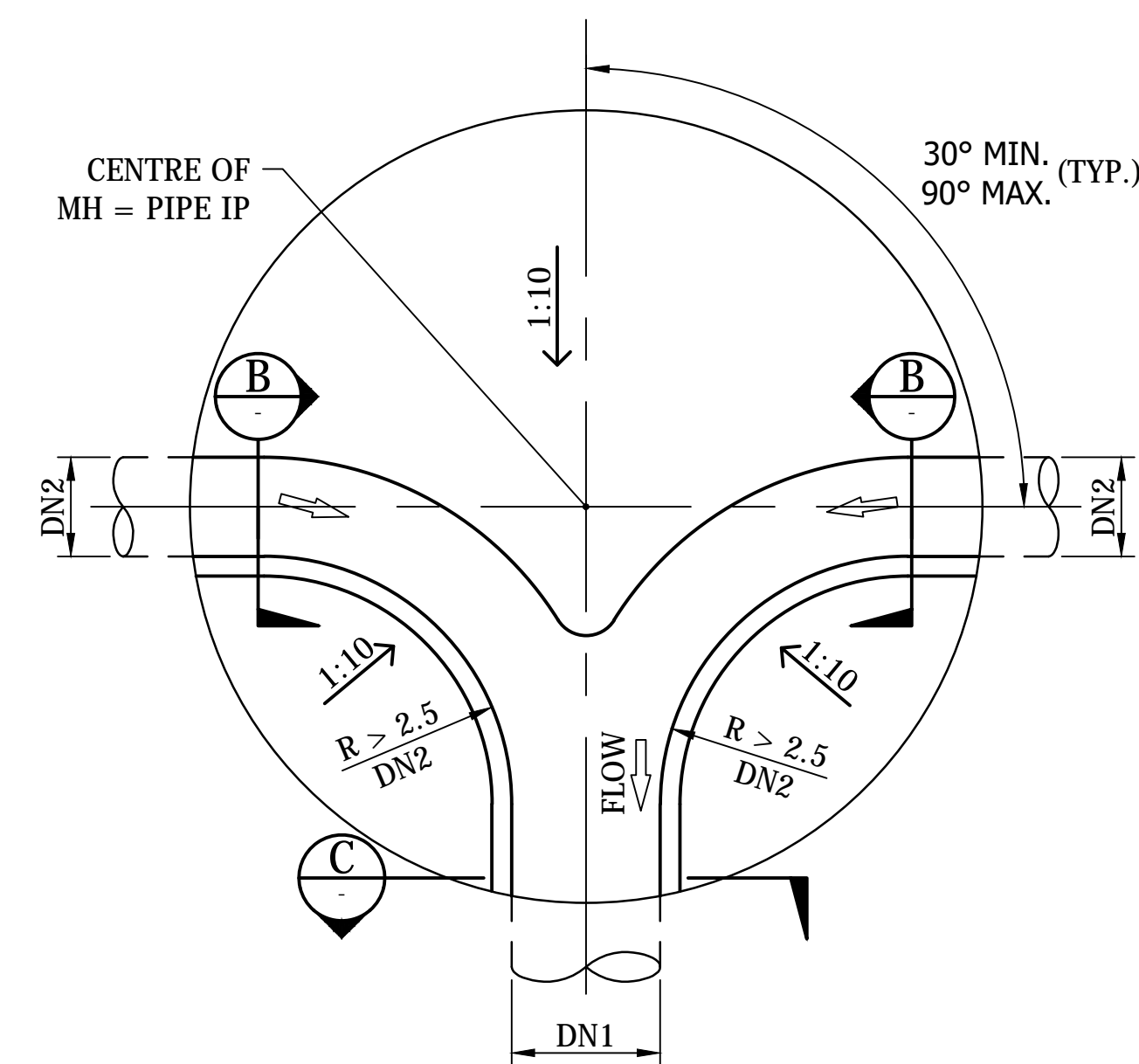

"T" - INTERSECTION
SCALE 1:10

NOTES:

- CONFIGURATIONS OF MAINTENANCE HOLES ON THIS SHEET REPRESENT THE MOST COMMON FOUND IN THE SEWERAGE SYSTEM. STANDARD CONFIGURATIONS INCLUDE:
 - DEFLECTIONS WITHIN LIMITS OF TABLE 1 AND TABLE 2.
 - SINGLE BRANCH JUNCTIONS AS PER TABLE 3 AND TABLE 4.
 - SMALL DIAMETER 'T' OR TWO BRANCH JUNCTIONS AS PER TABLE 5.
- THERE MAY BE OTHER CONFIGURATIONS WHICH ARE ACCEPTABLE. REFER TO WSA 02 (AS AMENDED BY ICON WATER) FOR DETAILS
- MAXIMUM DEFLECTION ON THE MAIN SEWER (DN1) THROUGH A SINGLE JUNCTION OR A DOUBLE BRANCH INTERSECTION IS LIMITED TO FIVE DEGREES. CONFIGURATIONS INVOLVING MAIN SEWER DEFLECTION GREATER THAN FIVE DEGREES SHALL BE DESIGNED IN THE CONTEXT OF NOTE 2 ABOVE.
- MINIMUM RADIUS OF CURVATURE OF BENCHING ON THE INSIDE OF THE CURVE WILL BE 2.5 TIMES THE DIAMETER.
- WHERE CURVATURE GREATER THAN 2.5 TIMES THE DIAMETER IS ACHIEVABLE, THE CENTRELINE OF THE CHANNEL IS TO DESCRIBE A SMOOTH CONSTANT RADIUS CURVE FROM INLET PIPE TO OUTLET PIPE.
- ALL SHARP EDGES TO BE MADE ROUNDED CHAMFERS.

TABLE 1

DN1050 MAINTENANCE HOLE								
PIPE DN	OFFSET "Z" FOR DEFLECTION ANGLE OF:							
	15°	30°	45°	60°	75°	90°	100°	110° (MAX)
150	0	0	100	150	200	300	300	400
225	0	0	100	150	200	82° MAX. 150 OFFSET		
300	0	0	100	150	60° MAX. 150 OFFSET			
375	0	100	150	45° MAX. 150 OFFSET				
450	0	0	38° MAX. 0 OFFSET					

TABLE 2

DN1200 MAINTENANCE HOLE								
PIPE DN	OFFSET "Z" FOR DEFLECTION ANGLE OF:							
	15°	30°	45°	60°	75°	90°	100°	110° (MAX)
150	0	0	100	150	200	300	300	400
225	0	0	100	150	200	300		
300	0	0	100	150	65° MAX. 150 OFFSET			
375	0	100	150	50° MAX. 150 OFFSET				
450	0	0	40° MAX. 100 OFFSET					

TABLE 3

STANDARD MH OFFSETS FOR SINGLE JUNCTIONS			
INTERMEDIATE VALUES TO BE INTERPOLATED			
DEFLECTION (MIN.) 30°	Δ X	Δ Y	NOTES
45°	100	220	
60°	120	130	
75°	150	80	
90°	170	-50	
(MAX.) 110°	200	-180	DN150 ONLY

TABLE 4

MINIMUM MH ID FOR SINGLE JUNCTIONS			
STANDARD OFFSETS AS PER TABLE 3			
DN1 (MAIN SEWER DIAMETER)	DN2 (BRANCH SEWER DIAMETER)		
	150	225	300
150	1050	N/A	N/A
225	1050	1200	N/A
300	1200	1200	1500
375	1200	1200	1500
450	1200	1200	1500

TABLE 5

MINIMUM MH ID FOR "T" AND TWO BRANCH JUNCTIONS			
DN1 (MAIN SEWER DIAMETER)	DN2 (BRANCH SEWER DIAMETER)		
	150	225	300
150	1050	N/A	N/A
225	1050	1500	N/A
300	1200	1500	1500
375	1200	1500	1500
450	1500	1500	1800

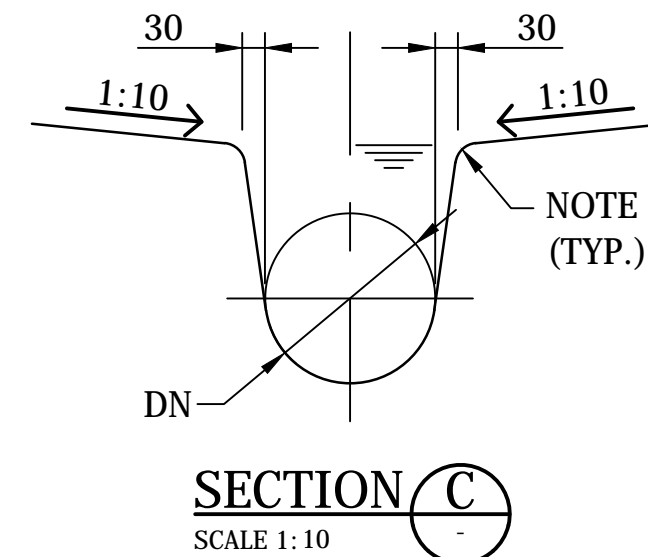
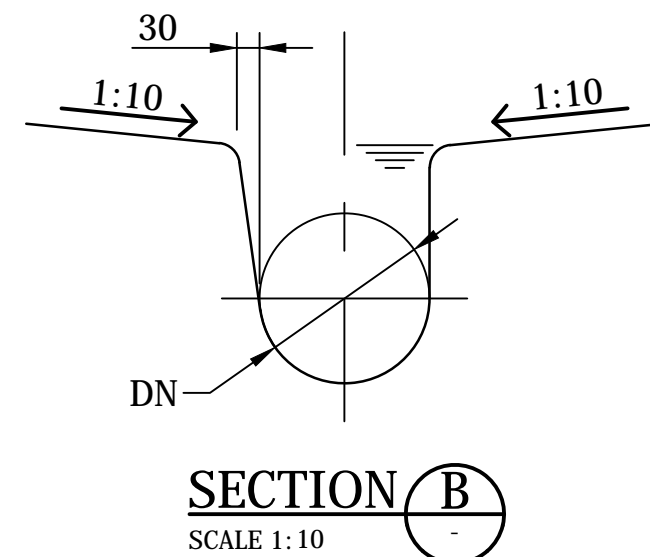
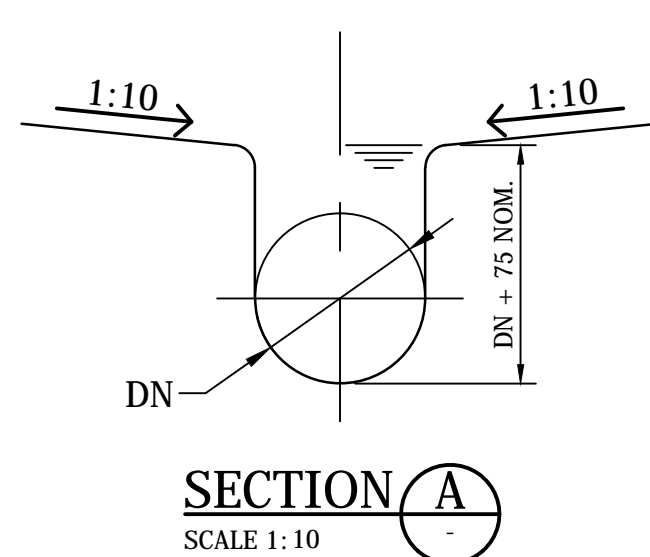

NOTE 6 (TYP.)

SCALE 1:10

DAM	RES	SPS	✗
BWS	WAT	STP	✗
WTP	SEW		
WPS	REC		
ASSET AREA APPLICABILITY			



STANDARD DRAWING
SEWERAGE NETWORK
PRECAST AND CAST IN SITU MAINTENANCE HOLES
STANDARD OFFSETS AND BENCHING
DETAILS

DRAWING STATUS		Current
SD-2208-D		ISSUE
A1	© Icon Water, 2017	B

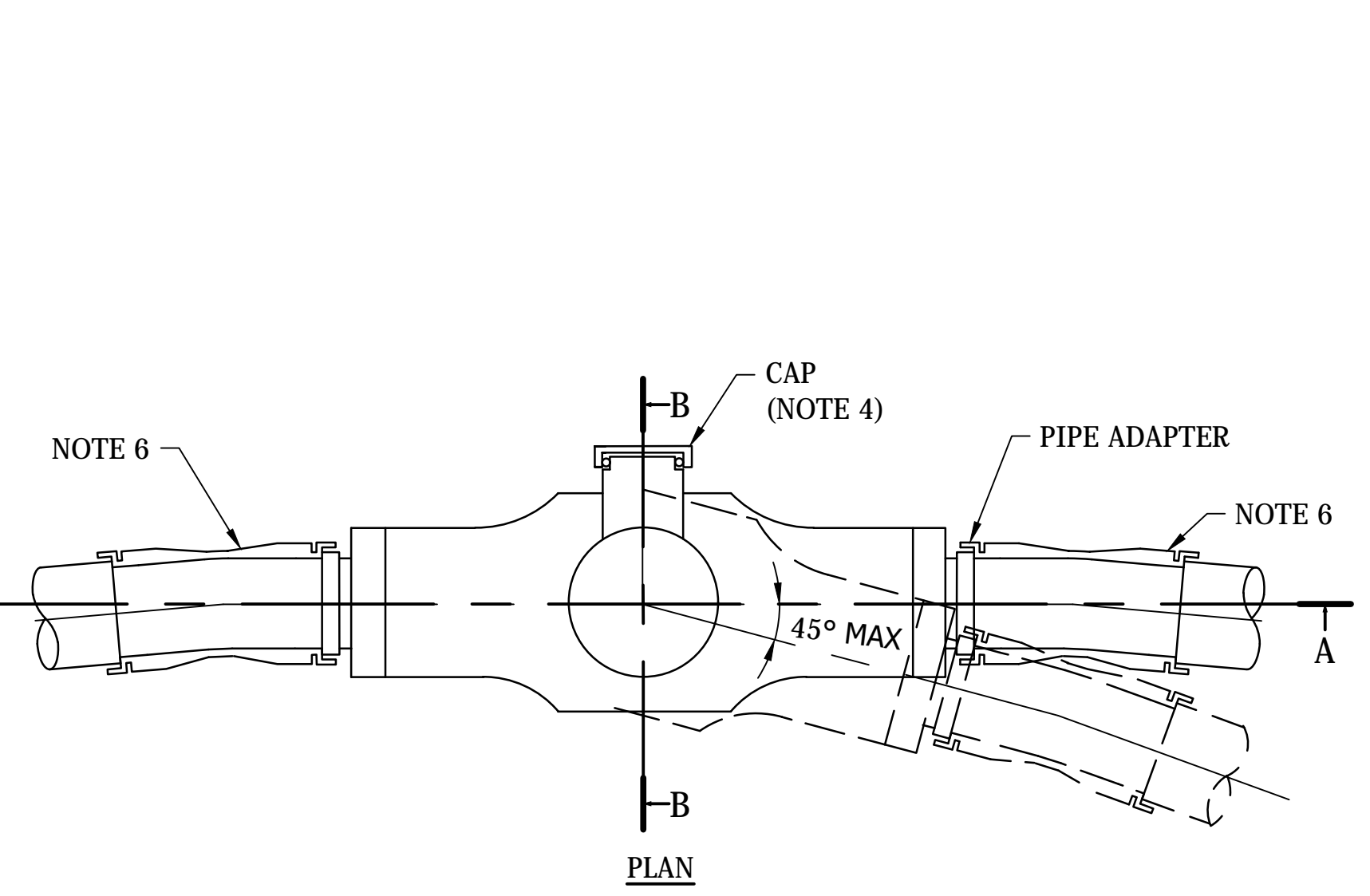
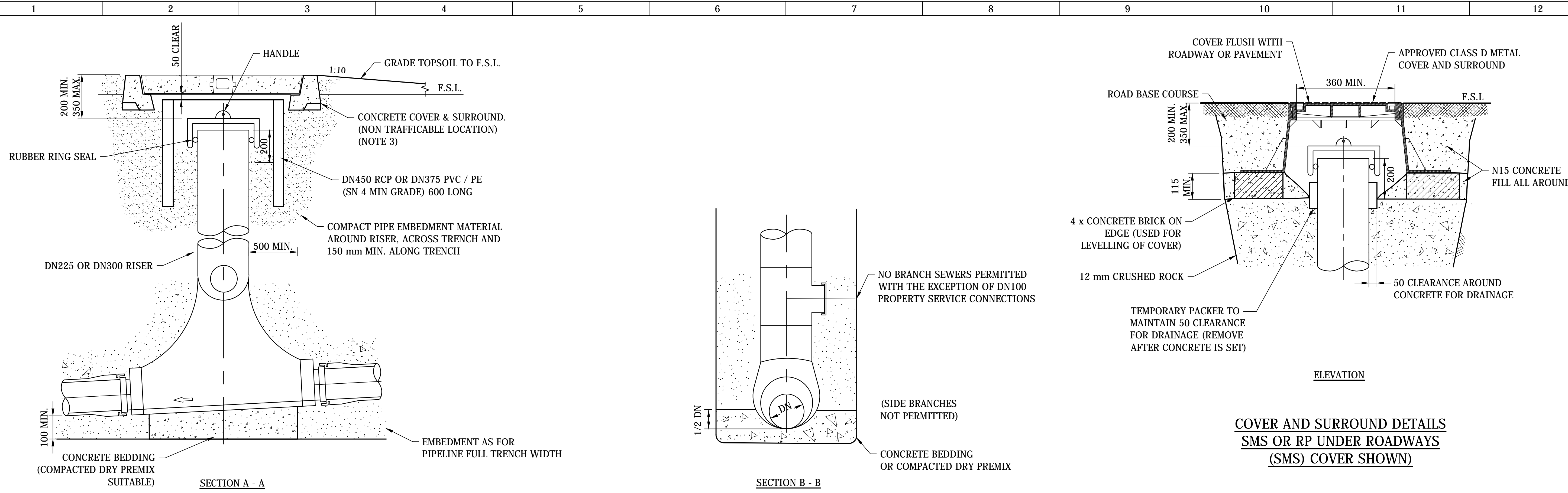

**SEWER MAINTENANCE SHAFT (SMS)
TYPICAL ARRANGEMENT
(FOR SEWER MAINS DN150 & DN225 ONLY)**

- NOTES:**
1. SHAFT MANUFACTURED FROM PVC (SOLVENT WELDED) OR PE (AS SINGLE UNIT). REFER TO THE ICON WATER APPROVED PRODUCTS LIST FOR ACCEPTED/APPROVED MAKES/MODELS.
 2. DEPTH TO INVERT MINIMUM 1150, MAXIMUM 7000.
 3. FOR ACCESS COVER DETAILS REFER TO SD-2204.
 4. ONLY DN100 PROPERTY SERVICE CONNECTIONS ALLOWED (NO BRANCH SEWERS).
 5. PIPE FITTINGS TO SUIT CONNECTING SEWERS.
 6. PERMITTED EXTERNAL BENDS ARE:
 - MAXIMUM OF 2 x 5° BENDS, ONE AT INLET ONE AT OUTLET.
 - BENDS ARE TO BE ADJACENT TO SHAFT.
 7. RODDING POINTS SHALL BE SHOWN AS RP AND SEWER MAINTENANCE SHAFTS AS SMS.
 8. FOR COMPACTION REQUIREMENTS REFER TO THE SD-2100 SERIES OF DRAWINGS.

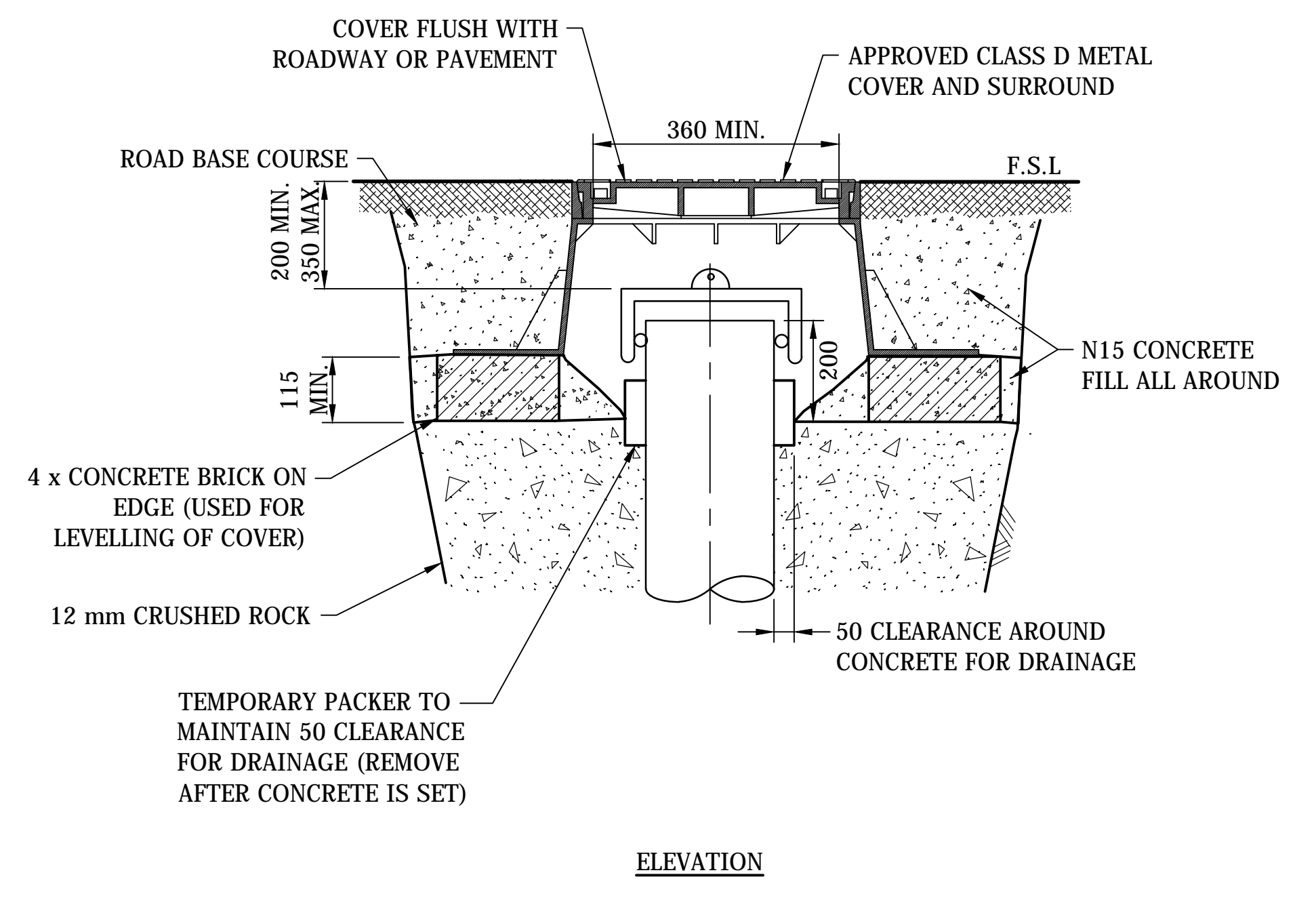
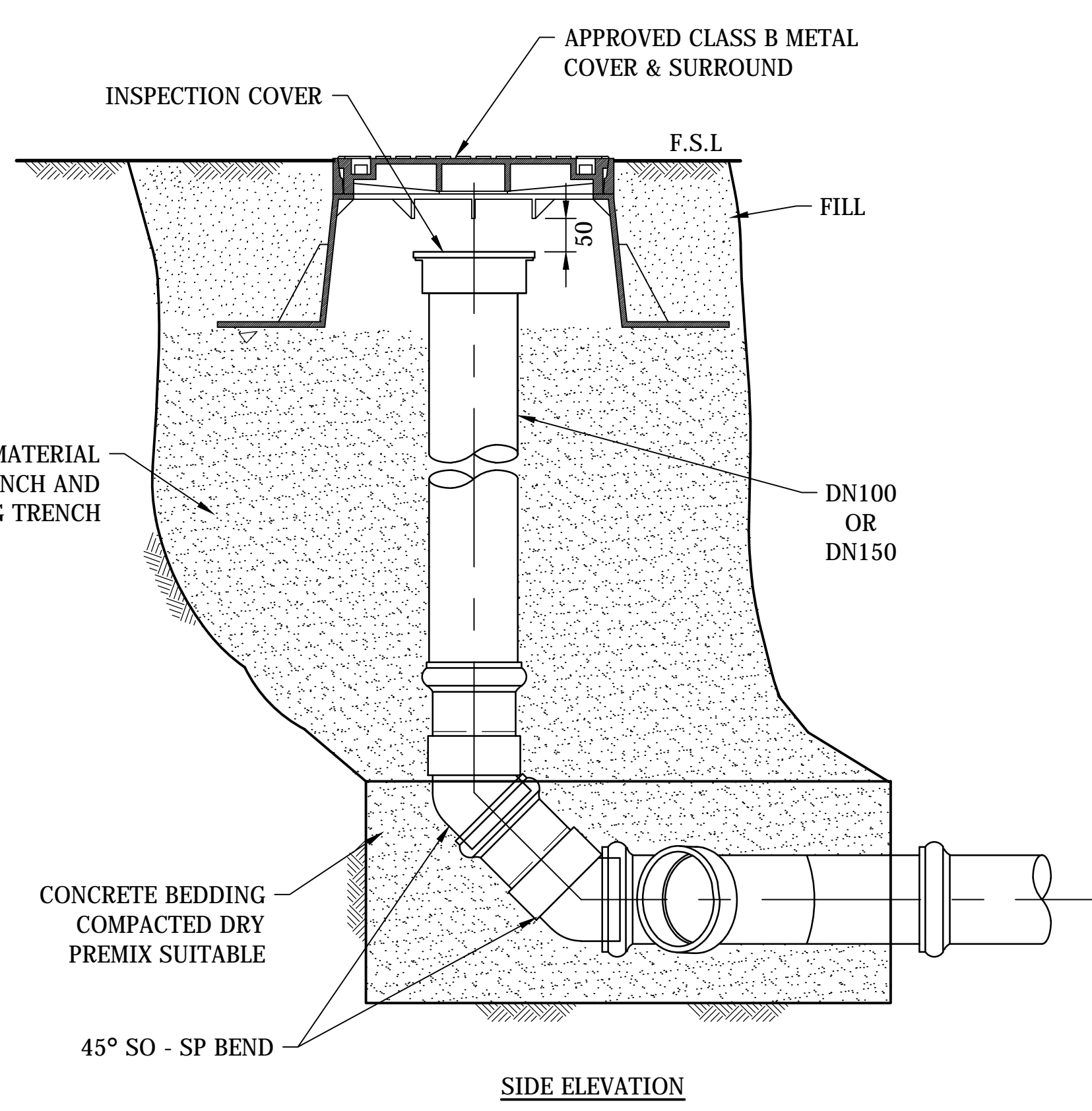
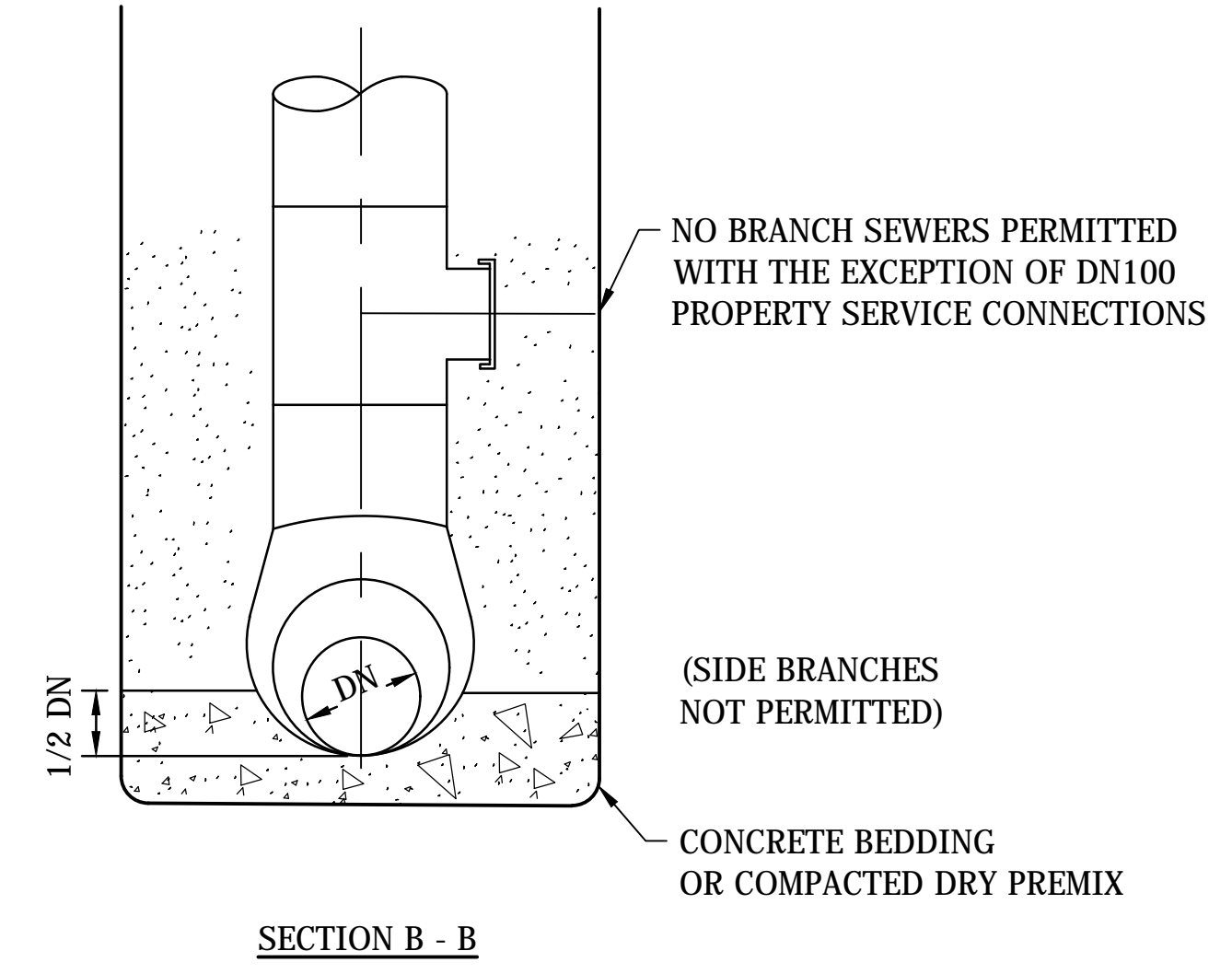

**COVER AND SURROUND DETAILS
SMS OR RP UNDER ROADWAYS
(SMS) COVER SHOWN)**

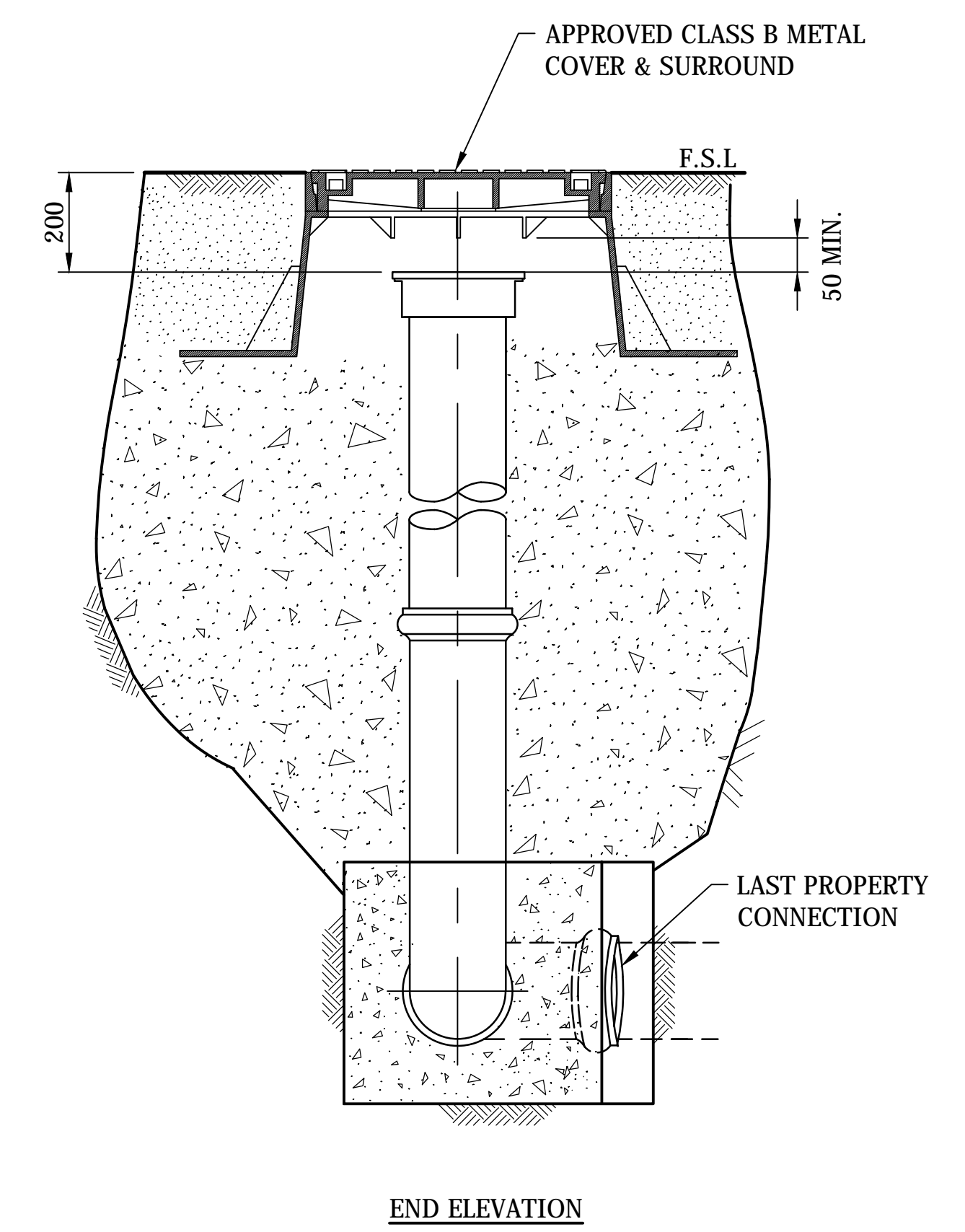

**RODDING POINTS AT DEAD ENDS (RP)
(NON - TRAFFICABLE AREAS)**

No.	ISSUE	DATE	DRAWN	CHECKED	AUTHORISED
A	INITIAL ISSUE	15/06/2018	M. Matusiak	K. Danenbergsons	D. Eager
B	DRAWING CHANGED TO - D	19/06/2019	S. Essery	K. Danenbergsons	C. Patrick

ASSET AREA APPLICABILITY				
DAM	RES	SPS	X	
BWS	WAT	STP	X	
WTP	SEW		X	
WPS	REC			



STANDARD DRAWING
SEWERAGE NETWORK
SEWER MAINTENANCE SHAFTS (SMS) AND RODDING POINTS
TYPICAL ARRANGEMENTS

DRAWING STATUS	
Current	
SD-2209-D	ISSUE
A1	B
© Icon Water, 2017	

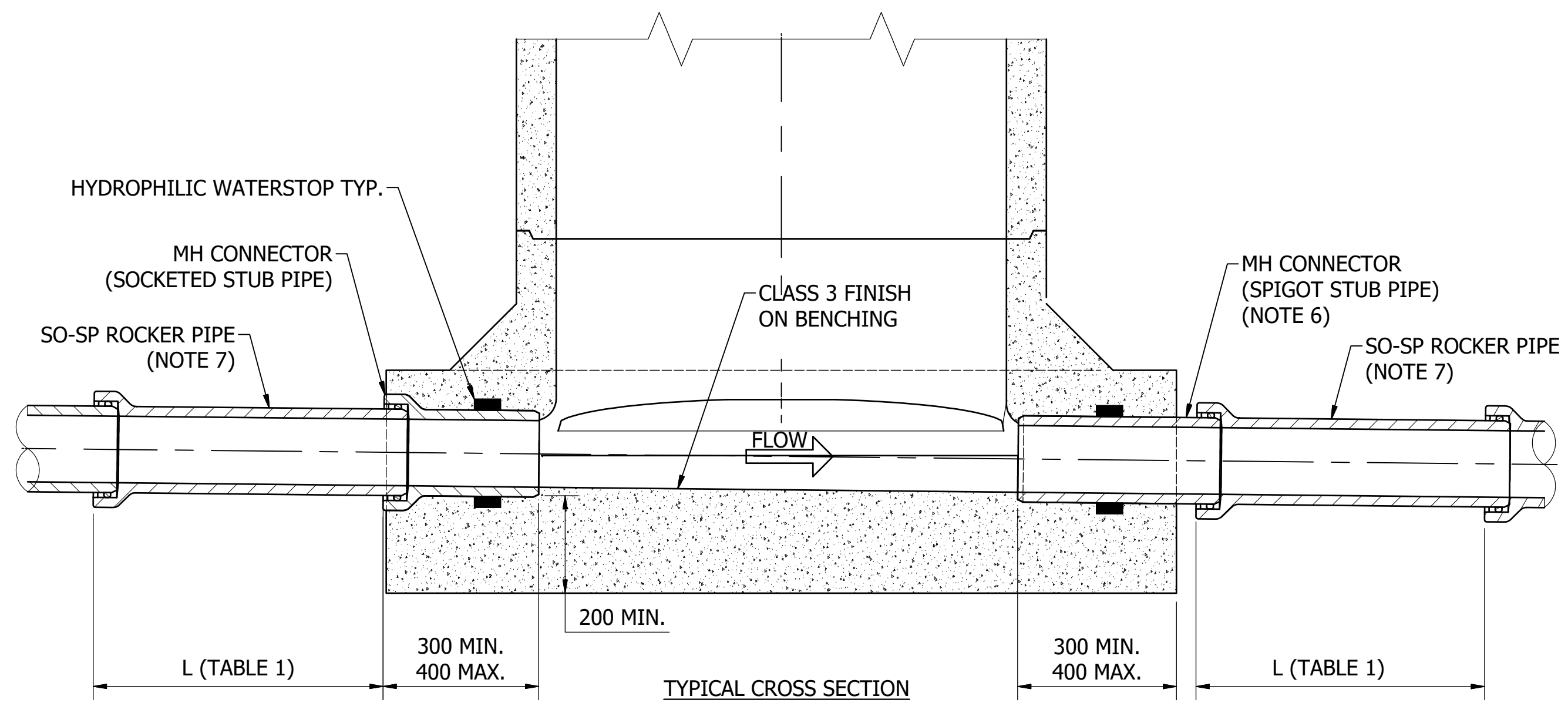

TYPICAL MAINTENANCE HOLE BASE FOR VC, RC AND DI SEWER MAINS
SCALE: 1 : 10

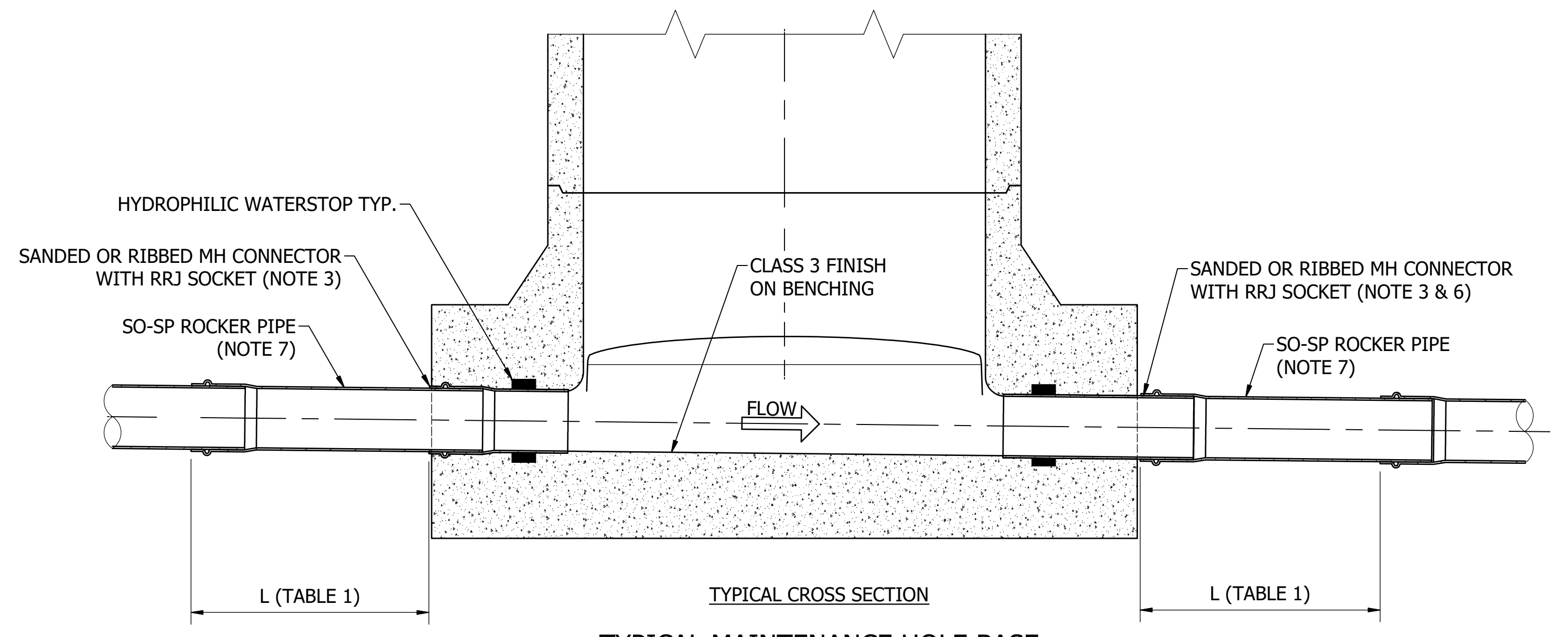

TYPICAL MAINTENANCE HOLE BASE FOR RUBBER RING JOINT PVC, SOLVENT CEMENT PVC & ABS SEWER MAINS
SCALE: 1 : 10

Sewer size DN	PVC		VC, RC	DI	GRP	
	"L" MIN	"L" MAX	"L"	"L"	"L" MIN	"L" MAX
150	300	450	600	1500	500	1000
225	450	650	600	1500	500	1000
300	600	900	700	1500	500	1000
375	750	1125	700	1500	500	1000

NOTE: THIS TABLE IS A DIRECT REPRODUCTION OF TABLE 7.3 OF WSA 02.

NOTES:

- PIPE CONNECTION DETAILS APPLY TO PRECAST AND CAST IN SITU MAINTENANCE HOLES (REFER SD-2201, SD-2205 & SD-2206).
- FORM ROUNDED NOSING ON INLET AND OUTLET PIPES TO PREVENT FUTURE DAMAGE TO JETTING EQUIPMENT, CCTV GUIDES AND CABLES.
- PVC, ABS & GRP MH CONNECTORS LARGER THAN DN300 TO HAVE WEEP RINGS AND TO BE SANDED.
- WHERE SPECIFIED, USE RRJ ROCKER PIPES AS SHOWN IN RRJ DETAIL WITH SOLVENT CEMENT JOINT PVC SEWERS.
- SOLVENT CEMENTED PVC SEWERS ARE NOT SUITABLE IF THE SOIL BEARING CAPACITY IS LESS THAN 100 kPa.
- SPIGOT STUB PIPES ARE TO EXTEND FROM THE MAINTENANCE HOLE SUCH THAT THE CONNECTING SOCKET IS AS CLOSE AS PRACTICABLE TO THE MAINTENANCE HOLE STRUCTURE.
- ROCKER PIPES AND ANY ASSOCIATED CONNECTIONS MUST BE COMPLETELY FREE FROM CONCRETE ENCASEMENT.

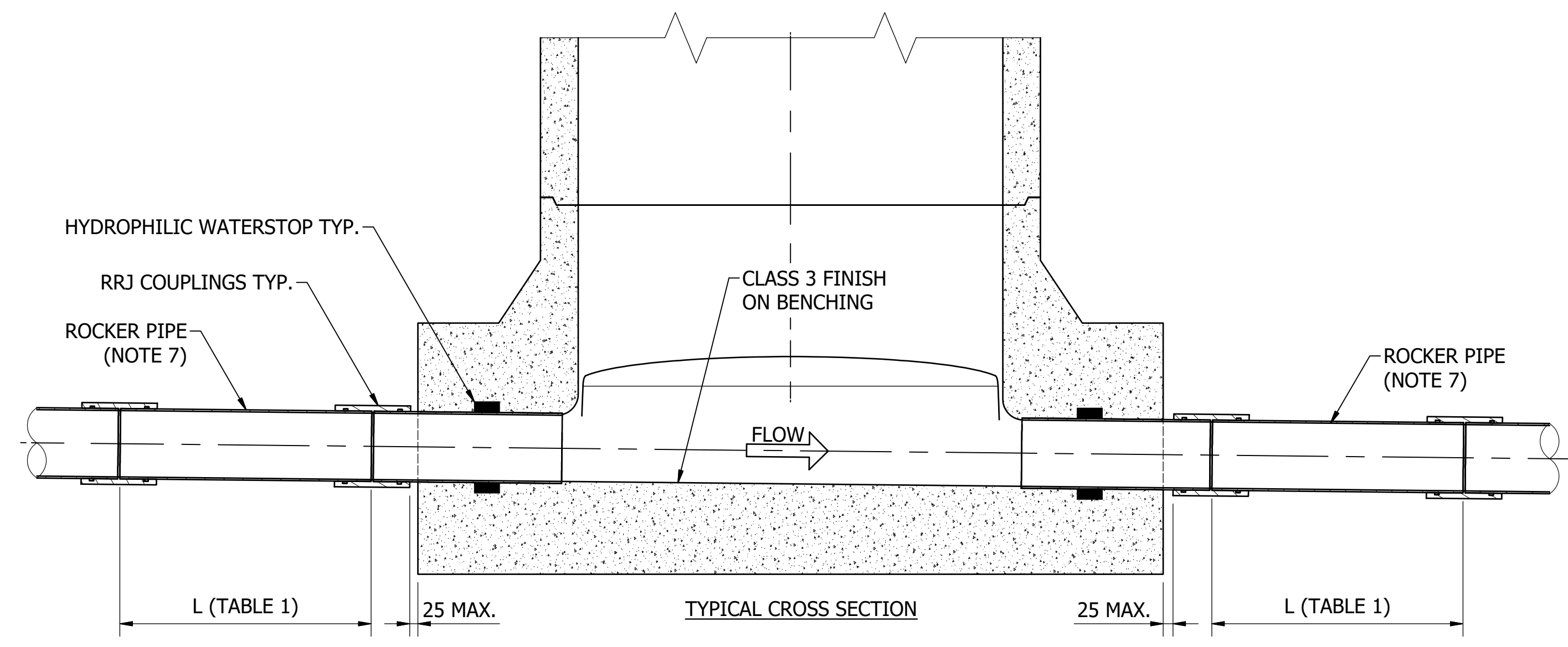

TYPICAL MAINTENANCE HOLE BASE FOR VC & GRP SLEEVE COUPLED SEWER MAINS
SCALE: 1 : 10

No.	ISSUE	DATE	DRAWN	CHECKED	AUTHORISED
A	INITIAL ISSUE	15/06/2018	M. Matusiak	K. Danenbergson	D. Eager
B	MODEL CORRECTION. DRAWING CHANGED TO -D	19/06/2019	S. Essery	K. Danenbergson	C. Patrick

ICON WATER ACKNOWLEDGES WATER SERVICES ASSOCIATION OF AUSTRALIA IN THE DEVELOPMENT OF THIS DRAWING. IN PARTICULAR, DRAWING SEW-1302

DAM	RES	SPS	WAT	STP



STANDARD DRAWING
SEWERAGE NETWORK
PRECAST AND CAST IN SITU MAINTENANCE HOLES
PIPE CONNECTION
DETAILS

DRAWING STATUS		Current
SD-2210-D		ISSUE B
A1	© Icon Water 2017	